

Motoman NX100 Controller

Inform II User's Manual

Part Number: 150078-1
Revision: 1



Motoman, Incorporated
805 Liberty Lane
West Carrollton, OH 45449
TEL: (937) 847-6200
FAX: (937) 847-6277
24-Hour Service Hotline: (937) 847-3200

COMPLETE OUR ONLINE SURVEY

Motoman is committed to total customer satisfaction! Please give us your feedback on the technical manuals you received with your Motoman robotic solution.

To participate, go to the following website:

<http://www.motoman.com/forms/techpubs.asp>

The information contained within this document is the proprietary property of Motoman, Inc., and may not be copied, reproduced or transmitted to other parties without the expressed written authorization of Motoman, Inc.

©2007 by MOTOMAN
All Rights Reserved

Because we are constantly improving our products, we reserve the right to change specifications without notice. MOTOMAN is a registered trademark of YASKAWA Electric Manufacturing.

Chapter 1

Introduction

This manual provides system information for Inform II and contains the following sections:

SECTION 1 - INTRODUCTION

Provides general information about the structure of this manual, a list of reference documents, and customer service information.

SECTION 2 - SAFETY

This section provides information regarding the safe use and operation of Motoman products.

SECTION 3 - INFORM II INSTRUCTIONS

Provides detailed information about the Inform II Function.

1.1 Reference to Other Documentation

For additional information refer to the following:

- NX100 Controller Manual (P/N 149201-1)
- Concurrent I/O Manual (P/N 149230-1)
- Operator's Manual for your application
- Vendor manuals for system components not manufactured by Motoman

1.2 Customer Service Information

If you are in need of technical assistance, contact the Motoman service staff at (937) 847-3200. Please have the following information ready before you call:

- Robot Type (EA1400, HP20, etc.)
- Application Type (arcwelding, spot welding, handling)
- Robot Serial Number (located on back side of robot arm)
- Robot Sales Order Number (located on back of controller)

NOTES

Chapter 2

Safety

2.1 Introduction

It is the purchaser's responsibility to ensure that all local, county, state, and national codes, regulations, rules, or laws relating to safety and safe operating conditions for each installation are met and followed.

We suggest that you obtain and review a copy of the ANSI/RIA National Safety Standard for Industrial Robots and Robot Systems. This information can be obtained from the Robotic Industries Association by requesting ANSI/RIA R15.06-1999. The address is as follows:

Robotic Industries Association
900 Victors Way
P.O. Box 3724
Ann Arbor, Michigan 48106
TEL: (734) 994-6088
FAX: (734) 994-3338
INTERNET: www.roboticsonline.com

Ultimately, the best safeguard is trained personnel. The user is responsible for providing personnel who are adequately trained to operate, program, and maintain the robot cell. **The robot must not be operated by personnel who have not been trained!**

We recommend that all personnel who intend to operate, program, repair, or use the robot system be trained in an approved Motoman training course and become familiar with the proper operation of the system.

This safety section addresses the following:

- Standard Conventions (Section 2.2)
- General Safeguarding Tips (Section 2.3)
- Mechanical Safety Devices (Section 2.4)
- Installation Safety (Section 2.5)
- Programming, Operation, and Maintenance Safety (Section 2.6)

2.2 Standard Conventions

This manual includes the following alerts – in descending order of severity – that are essential to the safety of personnel and equipment. As you read this manual, pay close attention to these alerts to insure safety when installing, operating, programming, and maintaining this equipment.



DANGER!

Information appearing in a **DANGER** concerns the protection of personnel from the immediate and imminent hazards that, if not avoided, will result in immediate, serious personal injury or loss of life in addition to equipment damage.



WARNING!

Information appearing in a **WARNING** concerns the protection of personnel and equipment from potential hazards that can result in personal injury or loss of life in addition to equipment damage.



CAUTION!

Information appearing in a **CAUTION** concerns the protection of personnel and equipment, software, and data from hazards that can result in minor personal injury or equipment damage.



Note: Information appearing in a Note provides additional information which is helpful in understanding the item being explained.

2.3 General Safeguarding Tips

All operators, programmers, plant and tooling engineers, maintenance personnel, supervisors, and anyone working near the robot must become familiar with the operation of this equipment. All personnel involved with the operation of the equipment must understand potential dangers of operation. General safeguarding tips are as follows:

- Improper operation can result in personal injury and/or damage to the equipment. Only trained personnel familiar with the operation of this robot, the operator's manuals, the system equipment, and options and accessories should be permitted to operate this robot system.
- Do not enter the robot cell while it is in automatic operation. Programmers must have the teach pendant when they enter the robot cell.
- Improper connections can damage the robot. All connections must be made within the standard voltage and current ratings of the robot I/O (Inputs and Outputs).
- The robot must be placed in Emergency Stop (E-STOP) mode whenever it is not in use.
- In accordance with ANSI/RIA R15.06-1999, section 4.2.5, Sources of Energy, use lockout/tagout procedures during equipment maintenance. Refer also to Section 1910.147 (29CFR, Part 1910), Occupational Safety and Health Standards for General Industry (OSHA).

2.4 Mechanical Safety Devices

The safe operation of the robot, positioner, auxiliary equipment, and system is ultimately the user's responsibility. The conditions under which the equipment will be operated safely should be reviewed by the user. The user must be aware of the various national codes, ANSI/RIA R15.06-1999 safety standards, and other local codes that may pertain to the installation and use of industrial equipment. Additional safety measures for personnel and equipment may be required depending on system installation, operation, and/or location. The following safety equipment is provided as standard:

- Safety fences and barriers
- Light curtains and/or safety mats
- Door interlocks
- Emergency stop palm buttons located on operator station, robot controller, and programming pendant

Check all safety equipment frequently for proper operation. Repair or replace any non-functioning safety equipment immediately.

2.5 Installation Safety

Safe installation is essential for protection of people and equipment. The following suggestions are intended to supplement, but not replace, existing federal, local, and state laws and regulations. Additional safety measures for personnel and equipment may be required depending on system installation, operation, and/or location. Installation tips are as follows:

- Be sure that only qualified personnel familiar with national codes, local codes, and ANSI/RIA R15.06-1999 safety standards are permitted to install the equipment.
- Identify the work envelope of each robot with floor markings, signs, and barriers.
- Position all controllers outside the robot work envelope.
- Whenever possible, install safety fences to protect against unauthorized entry into the work envelope.
- Eliminate areas where personnel might get trapped between a moving robot and other equipment (pinch points).
- Provide sufficient room inside the workcell to permit safe teaching and maintenance procedures.

2.6 Programming, Operation, and Maintenance Safety

All operators, programmers, plant and tooling engineers, maintenance personnel, supervisors, and anyone working near the robot must become familiar with the operation of this equipment. Improper operation can result in personal injury and/or damage to the equipment. Only trained personnel familiar with the operation, manuals, electrical design, and equipment interconnections of this robot should be permitted to program, operate, and maintain the system. All personnel involved with the operation of the equipment must understand potential dangers of operation.

- Inspect the robot and work envelope to be sure no potentially hazardous conditions exist. Be sure the area is clean and free of water, oil, debris, etc.
- Be sure that all safeguards are in place. Check all safety equipment for proper operation. Repair or replace any non-functioning safety equipment immediately.
- Do not enter the robot cell while it is in automatic operation. Be sure that only the person holding the programming pendant enters the workcell.
- Check the E-STOP button on the programming pendant for proper operation before programming. The robot must be placed in Emergency Stop (E-STOP) mode whenever it is not in use.
- Back up all programs and jobs onto suitable media before program changes are made. To avoid loss of information, programs, or jobs, a backup must always be made before any service procedures are done and before any changes are made to options, accessories, or equipment.

- Any modifications to PART 1, System Section, of the robot controller concurrent I/O program can cause severe personal injury or death, as well as damage to the robot! Do not make any modifications to PART 1, System Section. Making any changes without the written permission of Motoman will VOID YOUR WARRANTY!
- Some operations require standard passwords and some require special passwords. Special passwords are for Motoman use only. YOUR WARRANTY WILL BE VOID if you use these special passwords.
- The robot controller allows modifications of PART 2, User Section, of the concurrent I/O program and modifications to controller parameters for maximum robot performance. Great care must be taken when making these modifications. All modifications made to the controller will change the way the robot operates and can cause severe personal injury or death, as well as damage the robot and other parts of the system. Double-check all modifications under every mode of robot operation to ensure that you have not created hazards or dangerous situations.
- Check and test any new or modified program at low speed for at least one full cycle.
- This equipment has multiple sources of electrical supply. Electrical interconnections are made between the controller and other equipment. Disconnect and lockout/tagout all electrical circuits before making any modifications or connections.
- Do not perform any maintenance procedures before reading and understanding the proper procedures in the appropriate manual.
- Use proper replacement parts.
- Improper connections can damage the robot. All connections must be made within the standard voltage and current ratings of the robot I/O (Inputs and Outputs).

NOTES

NX100

INFORM MANUAL

Upon receipt of the product and prior to initial operation, read these instructions thoroughly, and retain for future reference.

MOTOMAN INSTRUCTIONS

MOTOMAN-□□□ INSTRUCTIONS
NX100 INSTRUCTIONS
NX100 OPERATOR'S MANUAL
NX100 MAINTENANCE MANUAL

The NX100 operator's manuals above correspond to specific usage.
Be sure to use the appropriate manual.





MANDATORY

- This manual explains the INFORM language of the NX100 system. Read this manual carefully and be sure to understand its contents before handling the NX100.
- General items related to safety are listed in the Section 1: Safety of the NX100 Instructions. To ensure correct and safe operation, carefully read the NX100 Instructions before reading this manual.



CAUTION

- Some drawings in this manual are shown with the protective covers or shields removed for clarity. Be sure all covers and shields are replaced before operating this product.
- The drawings and photos in this manual are representative examples and differences may exist between them and the delivered product.
- YASKAWA may modify this model without notice when necessary due to product improvements, modifications, or changes in specifications. If such modification is made, the manual number will also be revised.
- If your copy of the manual is damaged or lost, contact a YASKAWA representative to order a new copy. The representatives are listed on the back cover. Be sure to tell the representative the manual number listed on the front cover.
- YASKAWA is not responsible for incidents arising from unauthorized modification of its products. Unauthorized modification voids your product's warranty.

NOTES FOR SAFE OPERATION

Read this manual carefully before installation, operation, maintenance, or inspection of the NX100.

In this manual, the Notes for Safe Operation are classified as “WARNING”, “CAUTION”, “MANDATORY”, or “PROHIBITED”.



WARNING

Indicates a potentially hazardous situation which, if not avoided, could result in death or serious injury to personnel.



CAUTION

Indicates a potentially hazardous situation which, if not avoided, could result in minor or moderate injury to personnel and damage to equipment. It may also be used to alert against unsafe practices.



MANDATORY

Always be sure to follow explicitly the items listed under this heading.



PROHIBITED

Must never be performed.

Even items described as “CAUTION” may result in a serious accident in some situations. At any rate, be sure to follow these important items.



To ensure safe and efficient operation at all times, be sure to follow all instructions, even if not designated as “CAUTION” and “WARNING”.

WARNING

- Before operating the manipulator, check that servo power is turned OFF when the emergency stop buttons on the front door of the NX100 and programming pendant are pressed. When the servo power is turned OFF, the SERVO ON LED on the programming pendant is turned OFF.

Injury or damage to machinery may result if the emergency stop circuit cannot stop the manipulator during an emergency. The manipulator should not be used if the emergency stop buttons do not function.

Emergency Stop Button



- Once the emergency stop button is released, clear the cell of all items which could interfere with the operation of the manipulator. Then turn the servo power ON

Injury may result from unintentional or unexpected manipulator motion.

Release of Emergency Stop



- Observe the following precautions when performing teaching operations within the P-point maximum envelope of the manipulator:
 - View the manipulator from the front whenever possible.
 - Always follow the predetermined operating procedure.
 - Ensure that you have a safe place to retreat in case of emergency.

Improper or unintended manipulator operation may result in injury.

- Confirm that no person is present in the P-point maximum envelope of the manipulator and that you are in a safe location before:
 - Turning ON the NX100 power
 - Moving the manipulator with the programming pendant
 - Running the system in the check mode
 - Performing automatic operations

Injury may result if anyone enters the P-point maximum envelope of the manipulator during operation. Always press an emergency stop button immediately if there is a problem. The emergency stop buttons are located on the right of the front door of the NX100 and the programming pendant.



CAUTION

- Perform the following inspection procedures prior to conducting manipulator teaching. If problems are found, repair them immediately, and be sure that all other necessary processing has been performed.
 - Check for problems in manipulator movement.
 - Check for damage to insulation and sheathing of external wires.

- Always return the programming pendant to the hook on the NX100 cabinet after use.

The programming pendant can be damaged if it is left in the manipulator's work area, on the floor, or near fixtures.

- Read and understand the Explanation of the Warning Labels in the NX100 Instructions before operating the manipulator.

Definition of Terms Used Often in This Manual

The MOTOMAN manipulator is the YASKAWA industrial robot product.

The manipulator usually consists of the controller, the programming pendant, and supply cables.

In this manual, the equipment is designated as follows.

Equipment	Manual Designation
NX100 Controller	NX100
NX100 Programming Pendant	Programming Pendant
Cable between the manipulator and the controller	Manipulator Cable

Descriptions of the programming pendant keys, buttons, and displays are shown as follows:

Equipment		Manual Designation
Programming Pendant	Character Keys	The keys which have characters printed on them are denoted with []. ex. [ENTER]
	Symbol Keys	The keys which have a symbol printed on them are not denoted with [] but depicted with a small picture. ex. page key  The cursor key is an exception, and a picture is not shown.
	Axis Keys Numeric Keys	"Axis Keys" and "Numeric Keys" are generic names for the keys for axis operation and number input.
	Keys pressed simultaneously	When two keys are to be pressed simultaneously, the keys are shown with a "+" sign between them, ex. [SHIFT]+[COORD]
	Displays	The menu displayed in the programming pendant is denoted with { }. ex. {JOB}

Description of the Operation Procedure

In the explanation of the operation procedure, the expression "Select •••" means that the cursor is moved to the object item and the SELECT key is pressed.

1 INFORM Manual Outline

1.1	About INFORM	1-1
1.1.1	With INFORM II	1-1
1.1.2	Type of Instruction	1-1
1.1.3	Instruction Set	1-2
■	Selecting Instruction Set	1-2
1.1.4	Variables to be Used in Instructions	1-3
■	Set Value of Variable and Numeric Data	1-3
1.2	Registration of Instructions	1-4
1.2.1	Registration	1-4
1.2.2	Learning Function	1-5
1.3	Detail Edit Window	1-7
1.4	Registration of Expression	1-8
1.4.1	Expression	1-8
1.4.2	Registration	1-10
1.5	INFORM Structure	1-12
■	INFORM Structure Elements	1-13
■	Meaning of INFORM Structure	1-13
■	Explanation Table	1-14

2 INFORM Explanation

2.1	I/O Instructions	2-1
	DOUT	2-1
	DIN	2-4
	WAIT	2-7
	PULSE	2-12
	AOUT	2-15
	ARATION	2-16
	ARATIOF	2-20
	ANTOUT	2-21
2.2	Control Instruction	2-26
	JUMP	2-26
	CALL	2-30
	TIMER	2-33
	*(LABEL)	2-34
	'(COMMENT)	2-35
	RET	2-36
	NOP	2-37
	PAUSE	2-38
	CWAIT	2-39
	MSG	2-40
	ADVINIT	2-41
	ADVSTOP	2-42
2.3	Operating Instruction	2-43
	CLEAR	2-43
	INC	2-47
	DEC	2-49
	SET	2-51
	ADD	2-61
	SUB	2-70

MUL	2-80
DIV	2-90
CNVRT	2-99
AND	2-102
OR	2-104
NOT	2-106
XOR	2-108
MFRAME	2-110
SETE	2-113
GETE	2-116
GETS	2-118
SQRT	2-124
SIN	2-126
COS	2-128
ATAN	2-130
MULMAT	2-132
INVMAT	2-135
SETFILE	2-137
GETFILE	2-141
SETREG	2-143
GETREG	2-145
2.4 Move Instruction	2-147
MOVJ	2-147
MOVL	2-158
MOVC	2-169
MOVS	2-178
IMOV	2-187
SPEED	2-195
REFP	2-198
2.5 Shift Instruction	2-205
SFTON	2-205
SFTOF	2-210
MSHIFT	2-212
2.6 Instruction Which Adheres to an Instruction.	2-215
IF	2-215
UNTIL	2-228
ENWAIT	2-230
2.7 Arc Welding Instruction	2-231
ARCON	2-231
ARCOF	2-236
VWELD	2-240
AWELD	2-242
ARCSET	2-244
WVON	2-248
WVOF	2-254
ARCCTS	2-256
ARCCTE	2-260
2.8 Handling Instruction	2-264
HAND	2-264
HSEN	2-266
2.9 Spot Welding Instruction	2-268
GUNCL	2-268
SPOT	2-270
STROKE	2-274
STRWAIT	2-275
2.10 General-purpose Instruction	2-277
TOOLON	2-277
TOOLOF	2-279

1 INFORM Manual Outline

1.1 About INFORM

1.1.1 With INFORM II

The robot programming language used with NX100 is called INFORM II. INFORM II is composed of the instruction and the additional item (tag and numeric data).

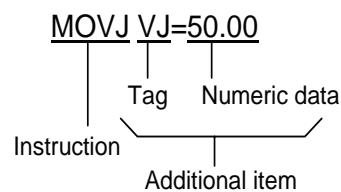

- **Instruction** : It is used to execute the operation and processing. In the case of a move instruction, when a position is taught, the move instruction is automatically displayed according to the interpolation method.
- **Additional item** : The speed, time, etc. are set according to the type of instruction. Numeric data and character data are added to the tag that specifies the condition as necessary.

1.1.2 Type of Instruction

The instruction is divided into several types in terms of each process and operation.

Type	Content	Instruction Example
I/O Instruction	It is the instruction used to control the I/O.	DOUT, WAIT
Control Instruction	It is the instruction used to control the processing and operation.	JUMP, TIMER
Operating Instruction	It is the instruction by which the variables, etc. are used and operated.	ADD, SET
Move Instruction	It is an instruction concerning the movement and the speed.	MOVJ, REFP
Shift Instruction	It is an instruction used when a present teaching position is shifted.	SFTON, SFTOF
Instruction which adheres to instruction	It is an instruction which adheres to the instruction.	IF, UNTIL
Work Instruction	It is an instruction concerning work, such as arc welding and handling.	ARCON, WVON
Optional Instruction	It is an instruction concerning optional functions. It can only be used when the function is available.	-

1.1.3 Instruction Set

To improve operation efficiency, the number of instructions to be registered is limited. All instructions are executed, regardless of the instruction set during playback, etc.

- **Subset Instruction Set**
Only high instructions which are used frequently are in the subset instruction set. The number of instructions is small, which allows for easier selecting and input.

- **Standard Instruction Set / Expanded Instruction Set**
All INFORM II instructions can be registered. For these two sets, the number of additional items which can be used by each instruction is different. The following function cannot be used with a standard instruction set, but operation is easier because the number of data decreases when the instruction is registered.
 - Local Variable, Use of Array Variable
 - Use of Variable to Additional Item (Ex. : MOVJ VJ=I000)

■ Selecting Instruction Set

Select an instruction set in the teaching condition window.

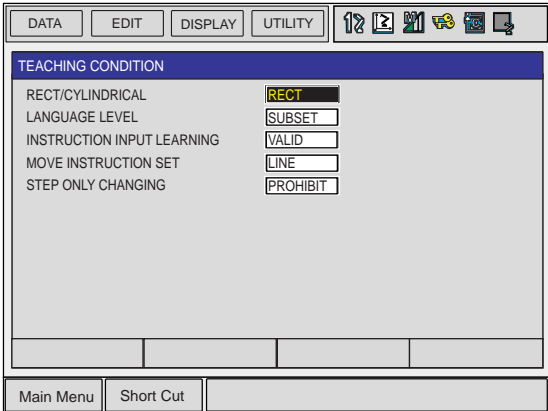
	Operation	Explanation
1	Select {SETUP} under the main menu	
2	Select {TEACHING COND}	The teaching condition window appears. <div style="border: 1px solid black; padding: 5px; margin-top: 10px;">  </div>

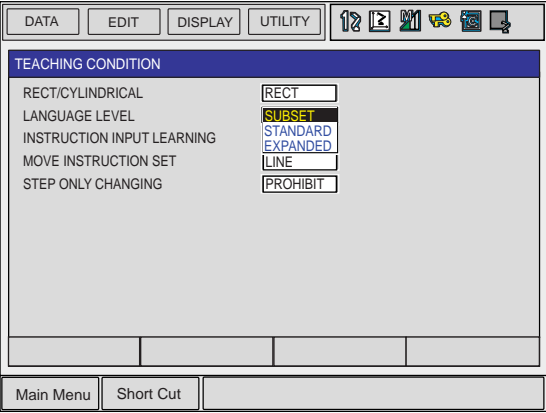
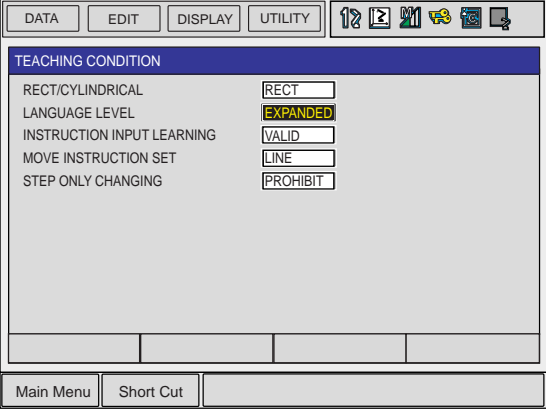
	Operation	Explanation
3	Select "LANGUAGE LEVEL"	<p>The instruction set selection dialog box appears.</p> 
4	Select the language level (instruction set)	<p>The language level is selected.</p> 

1.1.4 Variables to be Used in Instructions

Variables can be used as numeric data for the additional item of the instructions in the standard and expanded instruction sets.

Also, the instructions in the expanded instruction set can use local variables and array variables.



The applicable variable differs depending on the additional item. The number of local variables to be used must be set in the job header display. For setting the number of local variables, refer to the Operator's Manual "5.3.5 Editing Local Variables".

■ Set Value of Variable and Numeric Data

The unit of the numeric data for the additional item of the instruction decides the set value of variable and the value of the additional item at execution.

1.2 Registration of Instructions

< Example >

TIMER tag (T=)

TIMER T=I000

When a variable is used for the numeric data of the TIMER tag, the unit of numeric data is 0.01 seconds.

When 1000 is set for I000, the value when the instruction is executed is 10.00 seconds.

1.2 Registration of Instructions

1.2.1 Registration

Press [INFORM LIST]  while the job content window is shown to register instructions.

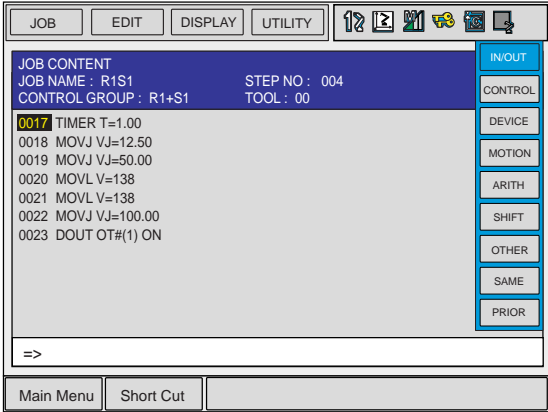
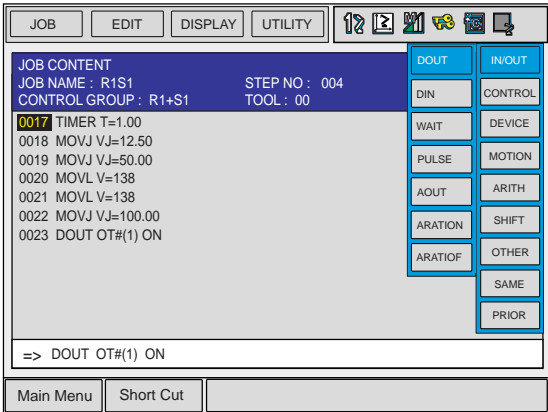
	Operation	Explanation
1	Select {JOB} under the main menu	
2	Select {JOB}	The job content window appears.
3	Press [INFORM LIST]	The job instruction group list dialog box appears. 
4	Select the desired instruction group	The job instruction list dialog box appears. 

	Operation	Explanation
5	Select the desired instruction	The instruction is displayed in the input buffer line.
6	Press [ENTER]	The instruction displayed in the input buffer line is registered in the job. Also, if the instruction must be registered during the job, press [INSERT] before pressing [ENTER]



Refer to the Operator's Manual "5.2 Editing Instructions" for details on editing instructions.

1.2.2 Learning Function

With the learning function, an instruction can be registered with the same additional items as those previously registered with the instruction.

Validate the learning function to minimize the number of instruction registries.

Set the learning function to valid or invalid in the teaching condition window.

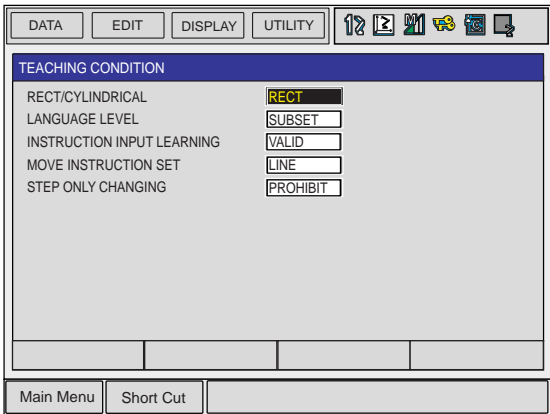
	Operation	Explanation
1	Select {SETUP} under the main menu	
2	Select {TEACHING COND}	The teaching condition window appears. 
3	Move the cursor to "INSTRUCTION INPUT LEARNING"	

1.2 Registration of Instructions

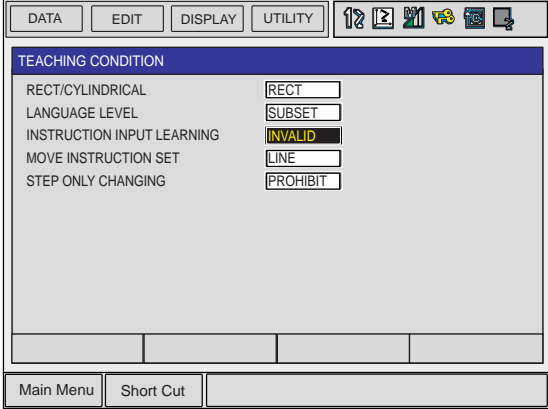
	Operation	Explanation
4	Press [SELECT]	<p>The condition "VALID" or "INVALID" is switchable each time [SELECT] is pressed.</p> 

1.3 Detail Edit Window

All instructions have a detail edit window.

The detail edit window is used for adding, modifying, and deleting additional items in the instruction.

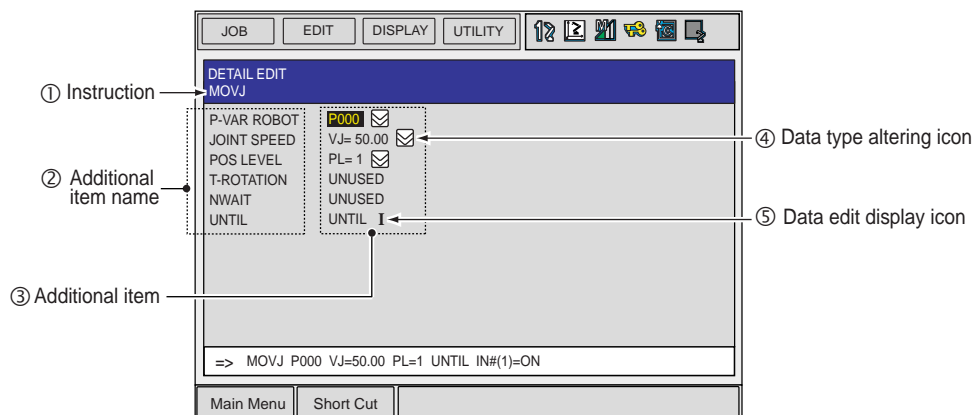

① Instructions

Indicates the instruction.

② Additional Item Name

Indicates the name of the additional item (type).

③ Additional Item

Indicates the additional item.

The tag selection dialog box appears when the cursor is on the additional item and [SELECT] is pressed.

When “NOT USED” is selected, the tag is omitted (if it can be omitted).

④ Data Type Altering Icon

Alters the type of numeric data.

For example, if the 50.00 of VJ=50.00 (constant type) is changed to I000 (integer-type variable), it becomes VJ=I000.

⑤ Detail Edit Display Icon

Indicates the detail edit display is shown.

1.4 Registration of Expression

1.4.1 Expression

With INFORM II, an expression can be added to the SET instruction.

< Example >

$$\text{SET } \underline{\text{B000}} \underline{(\text{B001} + \text{B002}) / \text{B003} - (\text{B004} + \text{B005}) * \text{B006}}$$

Result stored destination
Expression

Register an expression in the DETAIL EDIT window.



Expressions can be registered only when "STANDARD" or "EXPANDED" has been selected for the language level (instruction set).

The DETAIL EDIT window for expression is shown below.

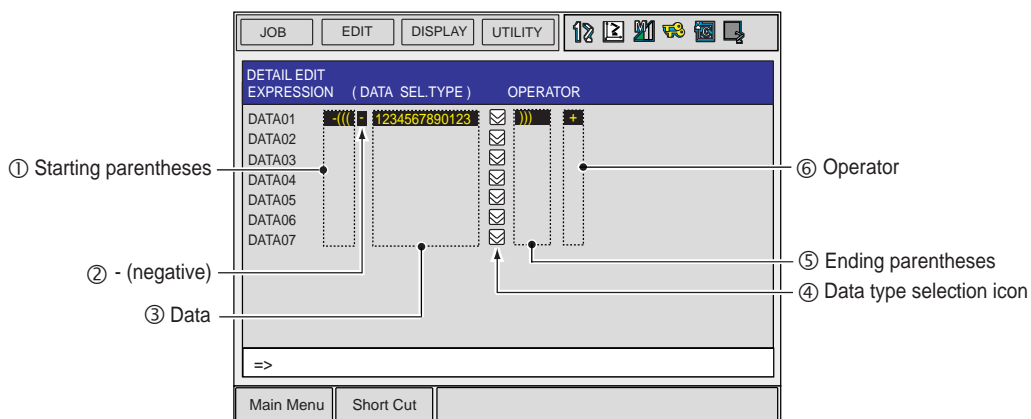

① Starting parentheses

Move the cursor to the parentheses, and press [SELECT]. Each time [SELECT] is pressed, three types of parentheses show up in the following order.

(→ ((→ (((→ -(→ -((→ -(((

② - (negative)

Move the cursor to the desired position, and press [SELECT]. Each time [SELECT] is pressed, the negative is alternately added and omitted and vice versa.

③Data

The data type of the expression is indicated. The following types of data can be registered.

- Constant (byte type, integer type, double-precision type, and real-number type)
- Byte type variable (B, B[], LB, and LB[])
- Integer type variable (I, I[], LI, and LI[])
- Double-precision type variable (D, D[], LD, and LD[])
- Real-number type variable (R, R[], LR, and LR[])

Move the cursor to the desired position, and press [SELECT] to enter the numeric value input status. Change the numeric value of the constant data and the variable number.

Change the data type by using the ④Data type selection icon.

④Data type selection icon

Change the data type in the following manner.

Move the cursor to the data type to be changed, and press [SELECT]. A dialog box with the selectable data types is displayed. Move the cursor to the data type to be selected and press [SELECT].

⑤Ending parentheses

Move the cursor to the parentheses and press [SELECT]. Each time [SELECT] is pressed, three types of parentheses show up in the following order.

) →)) →)))

⑥Operator

Move the cursor to the operator to be changed and press [SELECT]. The operator selection dialog box is displayed. Move the cursor to the operator to be selected and press [SELECT].

1.4 Registration of Expression

< Example of the DETAIL EDIT display for expression >

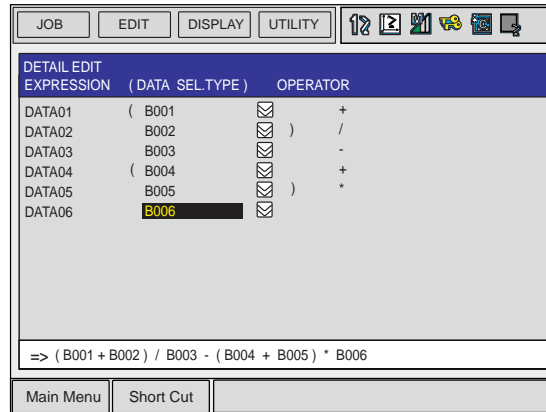
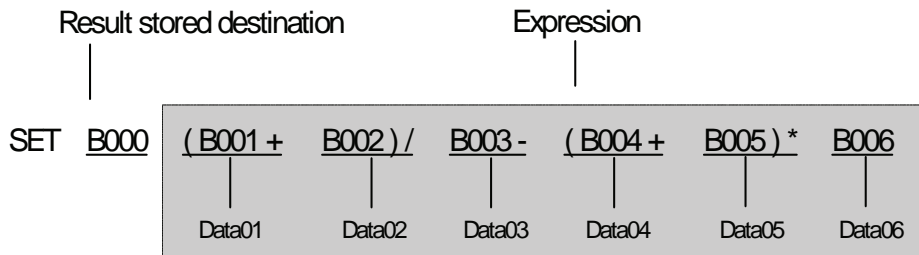

1.4.2 Registration

	Operation	Explanation
1	Select {JOB} under the main menu	
2	Select {JOB}	
3	Press [INFORM LIST]	
4	Select "ARITH"	
5	Select "SET"	
6	Press [SELECT]	The DETAIL EDIT window for the SET instruction appears.

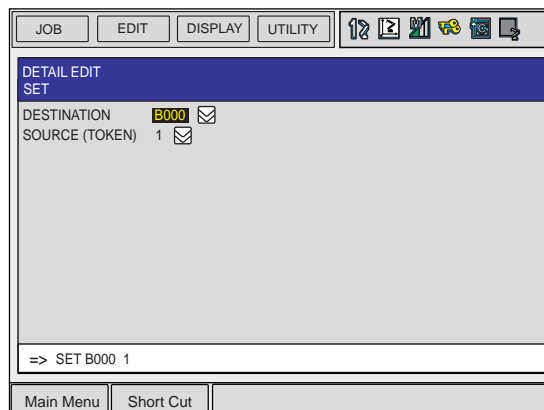

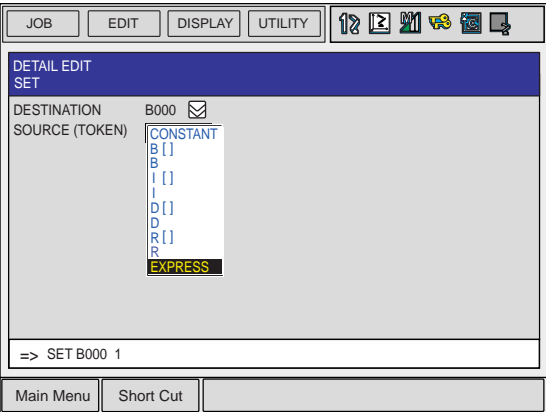
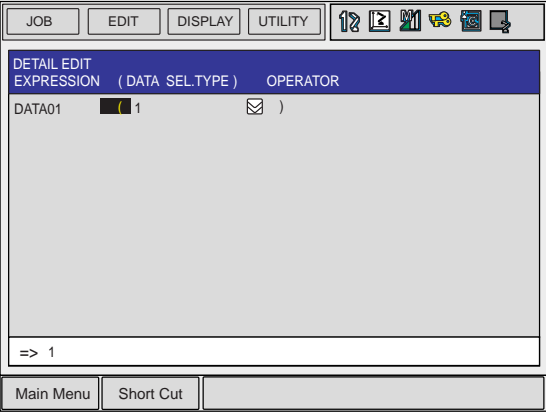
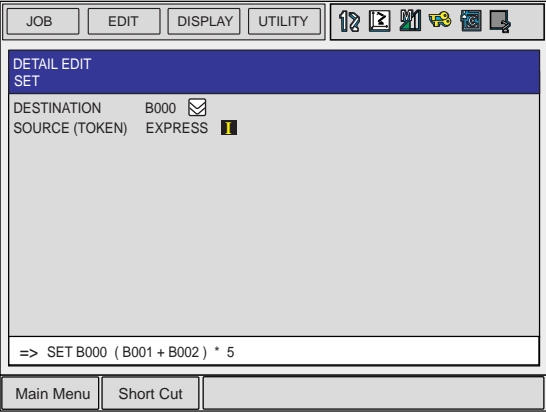
	Operation	Explanation
7	Move the cursor to the button <input type="checkbox"/> beside "SOURCE(TOKEN)"	
8	Press [SELECT]	<p>The selection dialog box appears.</p> 
9	Select "EXPRESS"	<p>The DETAIL EDIT window for expression appears.</p> 
10	Enter the expression and press [ENTER]	<p>The DETAIL EDIT window for the SET instruction appears.</p> 
11	Press [ENTER]	The JOB CONTENT window appears.
12	Press [ENTER]	The SET instruction indicated in the input buffer line is registered.

1.5 INFORM Structure

An example of the INFORM structure is shown in the following structure flowchart. The INFORM structure chart is composed of the structure elements (instruction, tag, and data). The order of the rows is shown with the numbers and arrows.

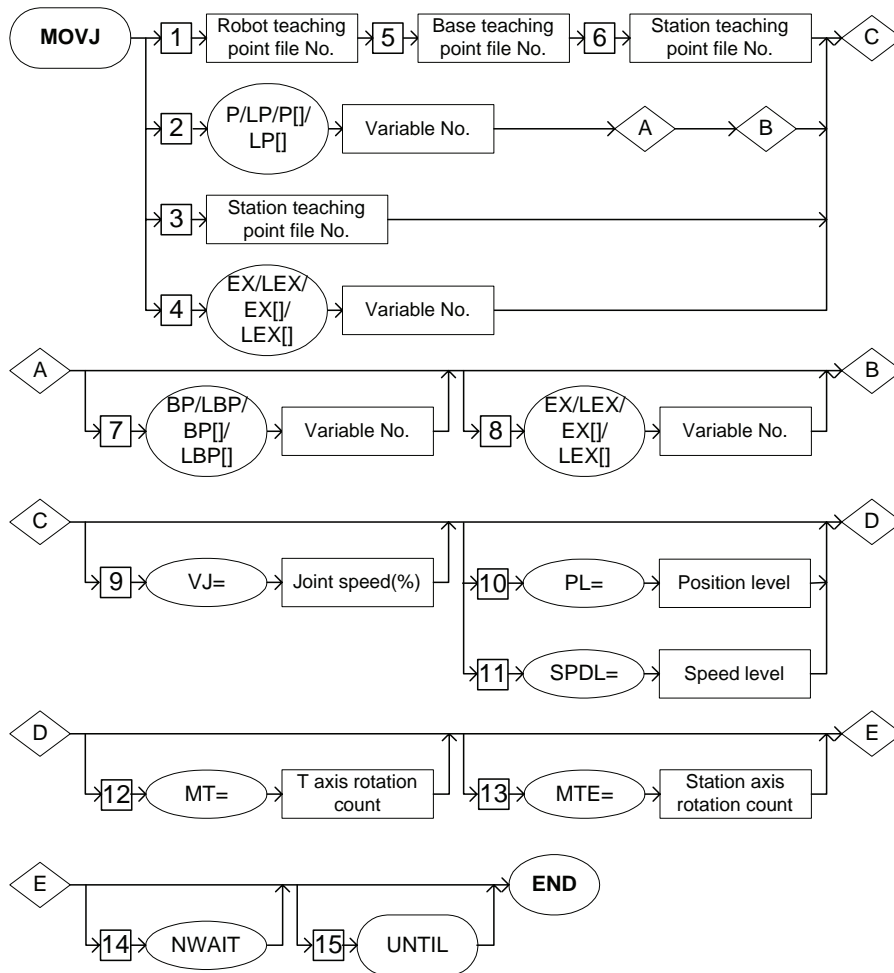

■ INFORM Structure Elements

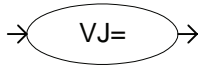
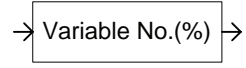
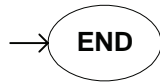
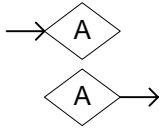
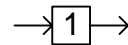
INFORM Structure Element	Explanation	Note
	Indicates the instruction.	In this example, the "MOVJ" instruction is indicated.
	Indicates the tag.	In this example, the "VJ=" instruction is indicated.
	Indicates the numeric data.	In this example, "Joint speed" is set with the unit %.
	Indicates the end of the instruction.	
	Indicates the connection.	
	Indicates the tag order.	

■ Meaning of INFORM Structure

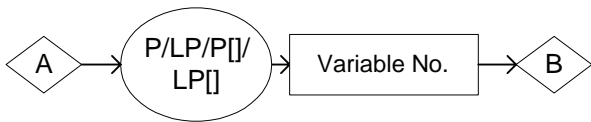
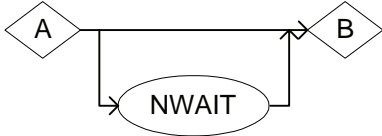
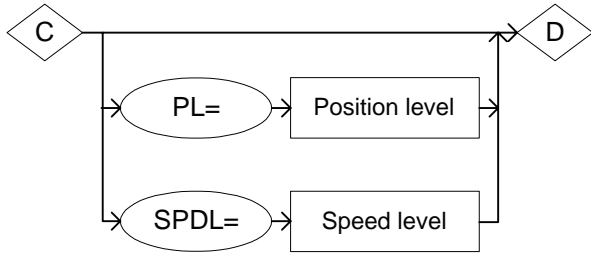
INFORM Structure	Meaning
	This is an indispensable tag. In this example, it is necessary to add a tag from [P Variable /LP Variable /P Array /LP Array].
	This is a tag that can be omitted. In this example, the NWAIT tag can be omitted.
	This is a tag that can be selected. In this example, either PL= tag or SPDL= tag can be selected.

■ Explanation Table

The explanation table in this manual can be described as follows.

No	Tag	Explanation	Note
1	OT # (Output number)	Specifies the output number signal.	No:1 to 1024 Variable B/I/D/LB/LI/ LD can be used.

- NO.
Indicates the tag number. Corresponds to the number in the INFORM structure.
- Tag
Indicates the surface description of the tag.
- Explanation
Provides an explanation of the tag.

2 INFORM Explanation

2.1 I/O Instructions

DOUT

Instruction set:

SUBSET	STANDARD	EXPANDED
Available	Available	Available

Function

Turns the general output signal on and off.

Construction

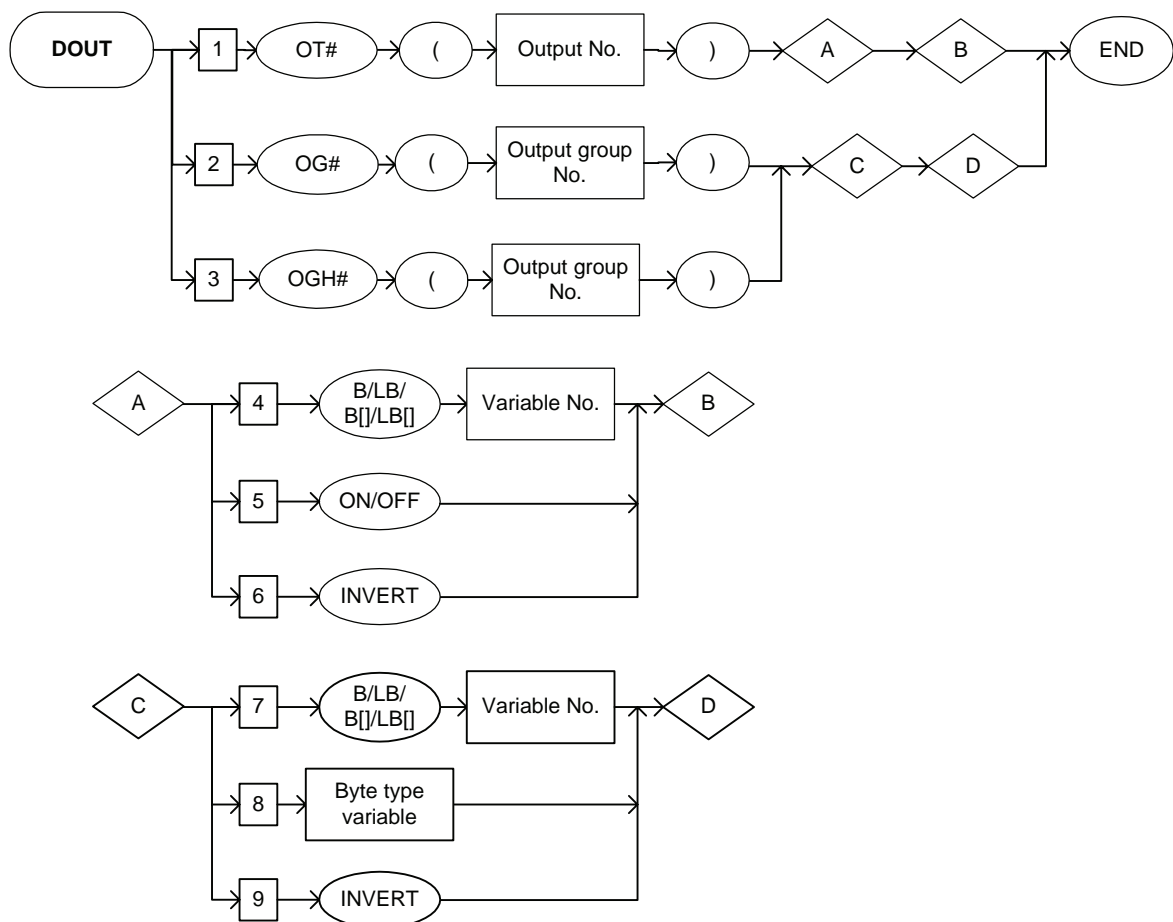

Explanation

1. OT# (Output number) /OG# (Output group number) /OGH# (Output group number)

Choose one of the tags from the following table.

No	Tag	Explanation	Note
1	OT#(Output number)	Specifies the output number signal.	No:1 to 1024 Variable B/I/D/LB/LI/LD can be used.
2	OG#(Output group number)	Specifies the output number group signal (1group 8 points).	No:1 to 128 Variable B/I/D/LB/LI/LD can be used.
3	OGH#(Output group number)	Specifies the output number group signal (1group 4 points).	No:1 to 256 Variable B/I/D/LB/LI/LD can be used.



Output signal

Output signal OT#(xx) is 1 point, OGH#(xx) is 1 group 4 points, and OG#(xx) is 1 group 8 points.

OT#(8)	OT#(7)	OT#(6)	OT#(5)	OT#(4)	OT#(3)	OT#(2)	OT#(1)
OGH#(2)				OGH#(1)			
OG#(1)							

2. B Variable number /LB Variable number /B [Array number] /LB [Array number] /ON /OFF /INVERT

When OT# (output number) is selected from the table in part 1 of this Explanation, choose one of the tags from the following table.

No	Tag	Explanation	Note
4	B Variable number/ LB Variable number / B [Array number]/ LB [Array number]	The least significant bit of the specified byte type variable specifies on/off of the output signal.	Least significant bit: 0: OFF 1: ON
5	ON/OFF	Specifies on/off of the output signal.	
6	INVERT	Refers the current signal status to output OFF when the status is ON, and output ON when the status is OFF.	

3. B Variable number / LB Variable number / B [Array number] / LB [Array number] / Byte type constant

When OG# (Output group number) or OGH# (Output group number) is selected from the table in part 1 of this Explanation, choose one of the tags from the following table.

No	Tag	Explanation	Note
7	B Variable number/ LB Variable number/ B [Array number]/ LB [Array number]	Specifies on/off of the output signal by the specified bit value byte type variable.	bit: 0: OFF 1: ON
8	Byte type constant	When the constant byte type is expressed in bit form, the corresponding on/off output signal is specified. Specifies on/off of the output signal by bit value.	
9	INVERT	Refers the current signal status to output OFF when the status is ON, and output ON when the status is OFF.	

Example

(1) DOUT OT#(12) ON
General output signal no. 12 is turned on.

(2) SET B000 24
DOUT OG#(3) B000
B000=24(Decimal)= 00011000(Binary)

OT#(24)	OT#(23)	OT#(22)	OT#(21)	OT#(20)	OT#(19)	OT#(18)	OT#(17)
OG#(3)							

ON

General output signals nos. 20 and 21 are turned on.

DIN

Instruction set:

SUBSET	STANDARD	EXPANDED
Available	Available	Available

Function

Refers to the byte type variable for the status of the signal.

Construction

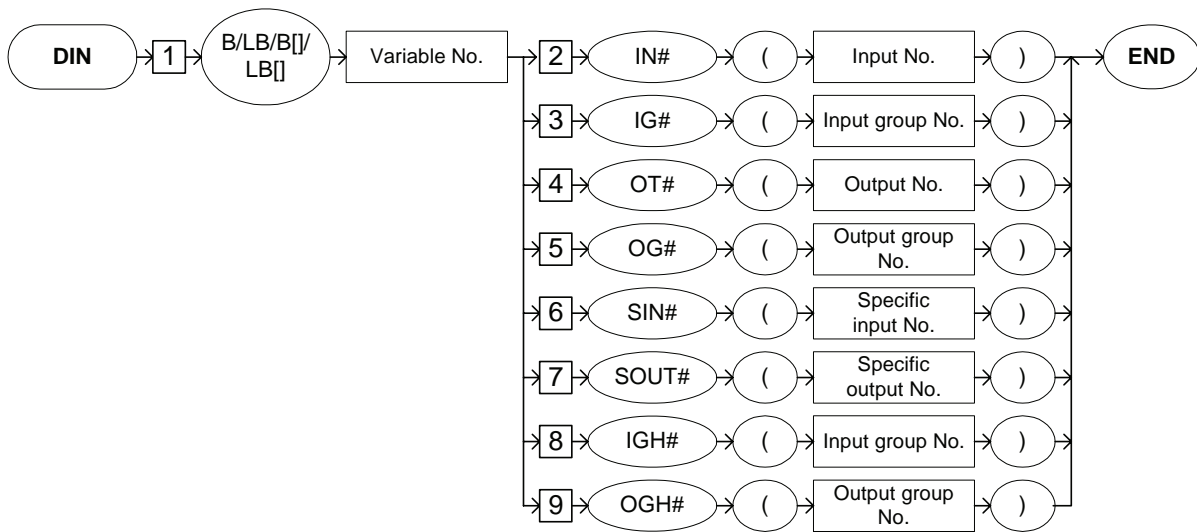

Explanation

1. B Variable Number / LB Variable Number / B [Array Number] / LB [Array Number]

Add the following tag.

No	Tag	Explanation	Note
1	B Variable Number/ LB Variable Number/ B [Array Number]/ LB [Array Number]	Specifies the number of byte type variable for the signal.	

2. IN#(Input number) / IG#(Input group number) / OT#(Output number) / OG#(Output group number) / SIN#(Specific input number) / SOUT#(Specific output number) / IGH#(Input group number) / OGH#(Output group number)

Choose one of the tags from the following table.

No	Tag	Explanation	Note
2	IN#(Input number)	Specifies the general input signal number which shows the signal status.	No:1 to 1024 Variable B/I/D/LB/LI/LD can be used.
3	IG#(Input group number)	Specifies the general input group signal number (1 group 8 points) which shows the signal status.	No:1 to 128 Variable B/I/D/LB/LI/LD can be used.
4	OT#(Output number)	Specifies the general output signal number which shows the signal status.	No:1 to 1024 Variable B/I/D/LB/LI/LD can be used.
5	OG#(Output group number)	Specifies the general output group signal number (1 group 8 points) which shows the signal status.	No:1 to 128 Variable B/I/D/LB/LI/LD can be used.
6	SIN#(Specific input number)	Specifies the specific input signal number which shows the signal status.	No:1 to 640 Variable B/I/D/LB/LI/LD can be used.
7	SOUT#(Specific output number)	Specifies the specific output signal number which shows the signal status.	No:1 to 800 Variable B/I/D/LB/LI/LD can be used.
8	IGH#(Input group number)	Specifies the general input group number (1 group 4 points) signal which shows the signal status.	No:1 to 256 Variable B/I/D/LB/LI/LD can be used.
9	OGH#(Output group number)	Specifies the number of general output group (1 group 4 points) signal which shows the signal status.	No:1 to 256 Variable B/I/D/LB/LI/LD can be used.



Input signal

Input signal IN#(xx) is 1 point, IGH#(xx) is 1 group 4 points, and IG#(xx) is 1group 8 points.

IN#(8)	IN#(7)	IN#(6)	IN#(5)	IN#(4)	IN#(3)	IN#(2)	IN#(1)
IGH#(2)				IGH#(1)			
IG#(1)							

Example

(1) DIN B016 IN#(12)

The on/off status of general input signal no.12 is shown in byte type variable No.16. When the general input signal No.12 is on, the status of the general input signal is B016=1 (decimal)=00000001(binary).

(2) DIN B002 OG#(8)

The on/off status of general output signal nos. 57-64 is shown in byte type variable No.2.

In the following cases, the status of the general output signal is B002=150 (decimal)= 10010110 (binary).

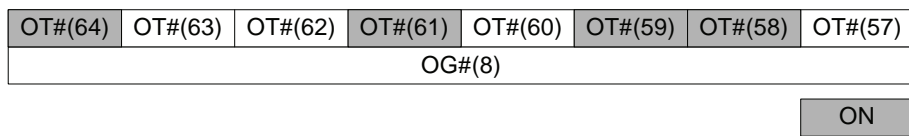

WAIT

Instruction set:

SUBSET	STANDARD	EXPANDED
Available	Available	Available

Function

Waits until the status of the external signal or byte type variable is the same as the specified status.

Construction

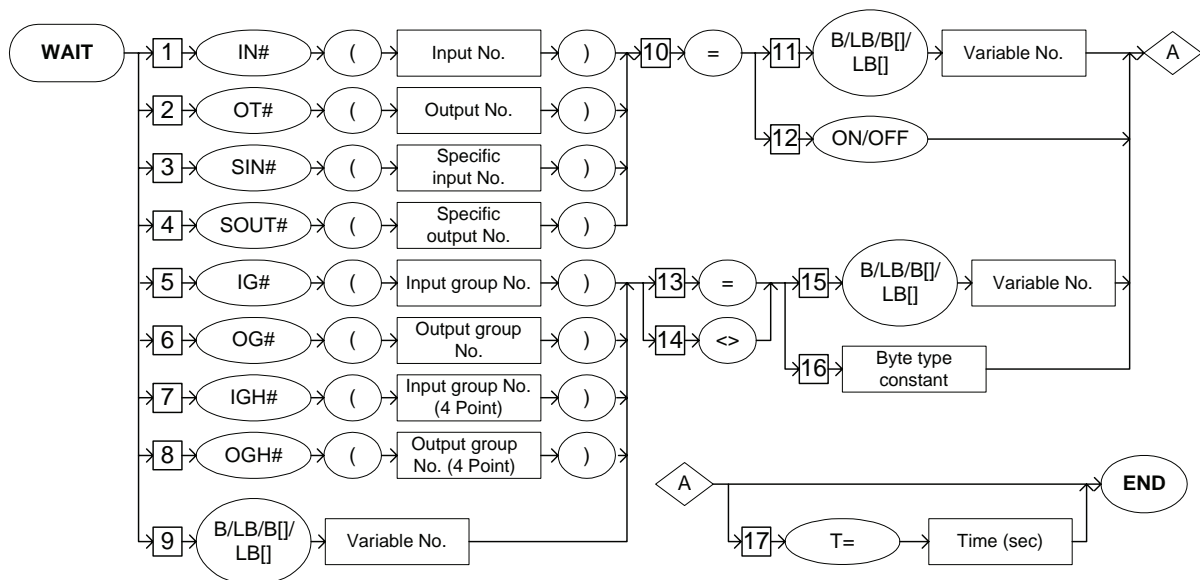

Explanation

1. IN#(Input number) / OT#(Output number) / SIN#(Specific input number) / SOUT#(Specific output number) / IG#(Input group number) / OG#(Output group number) / IGH#(Input group number) / OGH#(Output group number) / B Variable Number / LB Variable Number / B [Array Number] / LB [Array Number]

Choose one of the tags from the following table.

No	Tag	Explanation	Note
1	IN# (Input number)	Specifies the number of the general input signal for the waiting condition.	No:1 to 1024 Variable B/I/D/LB/LI/ LD can be used.
2	OT# (Output number)	Specifies the number of the general output signal for the waiting condition.	No:1 to 1024 Variable B/I/D/LB/LI/ LD can be used.
3	SIN# (Specific input number)	Specifies the number of the specific input signal for the waiting condition.	No:1 to 640 Variable B/I/D/LB/LI/ LD can be used.
4	SOUT# (Specific output number)	Specifies the number of the specific output signal for the waiting condition.	No:1 to 800 Variable B/I/D/LB/LI/ LD can be used.
5	IG#(Input group number)	Specifies the number of general input group (1 group 8 points) signal for the waiting condition.	No:1 to 128 Variable B/I/D/LB/LI/ LD can be used.
6	OG#(Output group number)	Specifies the number of general output group (1 group 8 points) signal for the waiting condition.	No:1 to 128 Variable B/I/D/LB/LI/ LD can be used.
7	IGH#(Input group number)	Specifies the number of general input group (1 group 4 points) signal for the waiting condition.	No:1 to 256 Variable B/I/D/LB/LI/ LD can be used.
8	OGH#(Output group number)	Specifies the number of general output group (1 group 4 points) signal for the waiting condition.	No:1 to 256 Variable B/I/D/LB/LI/ LD can be used.
9	B Variable number/ LB Variable number/ B [Array number]/ LB [Array number]	Specifies the byte type variable for the waiting condition.	

2. =

When an IN# (input number), OT# (output number), SIN# (specific input number), or SOUT# (specific output number) is selected from the table in part 1 of this Explanation, add the following tag.

No	Tag	Explanation	Note
10	=	It is equal.	

3. B Variable number /LB Variable number / B [Array number] / LB [Array number] / ON / OFF

When an IN# (input number), OT#(output number), SIN# (specific input number), or SOUT# (specific output number) is selected from the table in part 1 of this Explanation, choose one of the tags from the following table.

No	Tag	Explanation	Note
11	B Variable number/ LB Variable number/ B [Array number]/ LB [Array number]	Specifies byte type variable which becomes a waiting condition.	Least significant bit: 0:OFF 1:ON
12	ON/OFF	Specifies on/off of the waiting condition.	

4. =/<>

When an IG# (input group number), OG# (output group number), IGH# (input group number), OGH# (output group number), B variable number, LB variable number, B [array number], or LB [array number] is selected from the table in part 1 of this Explanation, choose one of the tags from the following table.

No	Tag	Explanation	Note
13	=	It is equal.	
14	<>	It is not equal.	

5. B Variable number / LB Variable number / B [Array number] / LB [Array number] / Byte type constant

When an IG# (input group number), OG# (output group number), IGH# (input group number), OGH# (output group number), B variable number, LB variable number, B [array number], or LB [array number] is selected from the table in part 1 of this Explanation, choose one of the tags from the following table.

No	Tag	Explanation	Note
15	B Variable number/ LB Variable number/ B [Array number]/ LB [Array number]	Specifies byte type variable which becomes a waiting condition.	
16	Byte type constant	The waiting condition is specified by byte type constant.	

6. T=time

The following tag can be added or omitted.

No	Tag	Explanation	Note
17	T=time	Specify the waiting time. When the time specified here ends, if the status and the condition are not the same, the next instruction is executed.	Unit: Second It is possible to specify at time by the I/LI/I/LI variable (Units: 0.01 seconds).

Example

(1) WAIT IN#(12)=ON

Waits until general input signal no.12 is turned on.

(2) SET B000 5

SET B002 16

WAIT SIN#(B000)=B002 T=3.0

B002=16 (Decimal)=00010000 (Binary)

Waits until specific input signal no.5 is turned off.

However, after three seconds, even if the signal is not turned off, the next instruction is executed.

(3) WAIT IGH#(2)<>5

5 (Decimal)=0101 (Binary)

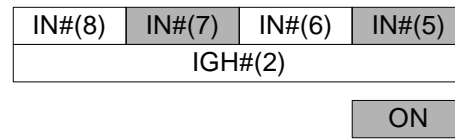

Waits until general input signal nos.5 and 7 are turned off and general input signal nos. 6 and 8 are turned on.

(4) Example of press machine handling.

```

000 NOP
001 MOVJ VJ=100.0
002 MOVJ VJ=100.0
    WAIT IN#(1)=ON
003 MOVJ VJ=100.0
004 MOVJ VJ=100.0
005 MOVJ VJ=100.0
006 MOVJ VJ=100.0
007 MOVJ VJ=100.0
008 MOVJ VJ=100.0
009 END

```

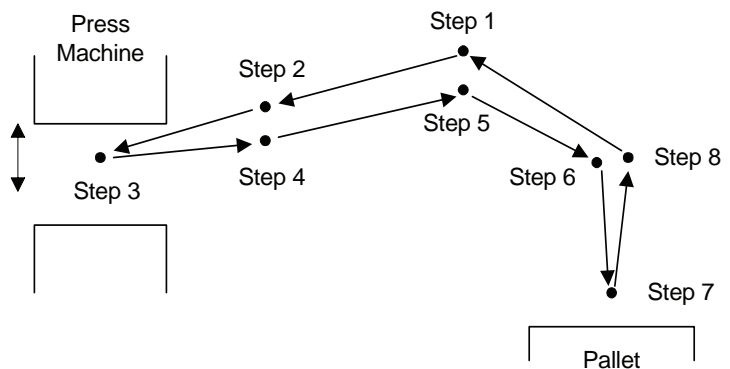

The robot cannot be moved to step 3 while the press is closed.

Open/close of the press machine (Open: ON, Shut: OFF) is allocated to general input signal No.1.

The robot waits until general input signal No.1 turns on at step 2.

PULSE

Instruction set:

SUBSET	STANDARD	EXPANDED
Available	Available	Available

Function

The pulse signal is output to the general output signal only for the specified time. The PULSE instruction, without waiting for completion of the instruction, executes the next one.

Construction

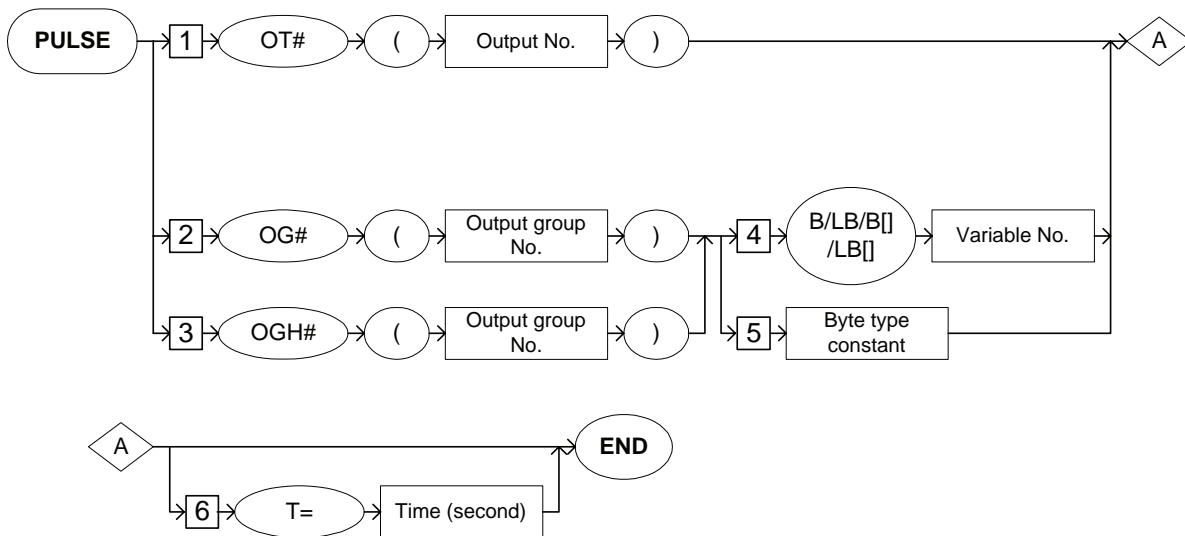

Explanation

1. OT# (output number) / OG# (output group number) / OGH# (output group number)

Choose one of the tags from the following table.

No	Tag	Explanation	Note
1	OT# (Output No.)	Specifies the number of the signal to which the pulse signal is output.	No.: 1 to 1024 Variable B/I/D/LB/LI/ LD can be used.
2	OG# (Output group No.)	Specifies the group number of the signal (1 group 8 points) to which the pulse signal is output.	No.: 1 to 128 Variable B/I/D/LB/LI/ LD can be used.
3	OGH# (Output group No.)	Specifies the group number of the signal (1 group 4 points) to which the pulse signal is output.	No.: 1 to 256 Variable B/I/D/LB/LI/ LD can be used.

2. B Variable number / LB Variable number / B [Array number] / LB [Array number] / Byte type constant

When OG# (output group number) or OGH# (output group number) in the above table is selected, choose one of the tags from the following table.

No.	Tag	Explanation	Note
4	B Variable number/ LB Variable number/ B [Array Number] / LB [Array Number]	Specifies the number of the corresponding pulse output signal when the contents of the specified byte type variable is expressed in bits.	Bit: 0: OFF 1: ON
5	Byte type constant	Specifies the number of the corresponding pulse output signal when the specified byte type constant is expressed in bits.	

3. T=Time

The following tag can be added or omitted.

No.	Tag	Explanation	Note
6	T=Time	Specifies the time during which the pulse signal is output. The pulse signal is output during the specified time T.	Units: seconds Variable I/LI/I[]/LI[] can be used. (Units: 0.01 seconds) When the time is not specified, the pulse signal is output during 0.30 seconds.

Example

(1) PULSE OT#(128)

The pulse signal is output for 0.30 seconds to general output signal No.128.

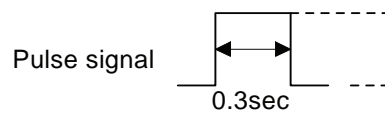

(2) SET B000 5

PULSE OT#(B000) T=1.0

The pulse signal is output for 1.0 seconds to general output signal No.5.

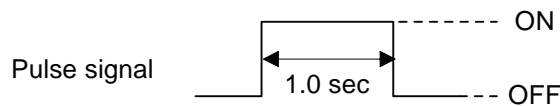

(3) SET B000 24

PULSE OG#(3) B000

B000=24 (Decimal)=00011000 (Binary)

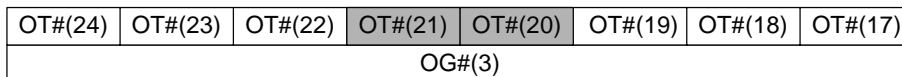

ON

The pulse signal is output for 0.30 seconds to the general output signal No.'s 20 and 21.

AOUT

Instruction set:

SUBSET	STANDARD	EXPANDED
Not available	Available	Available

Function

Outputs the set voltage value to the general-purpose analog output port.

Construction

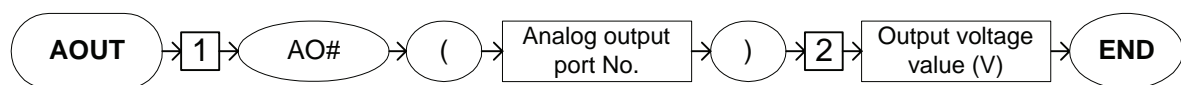

Explanation

1. AO# (Analog output port number)

Add the following tag.

No	Tag	Explanation	Note
1	AO# (Analog output port number)	Specifies the number of the analog output port to which the set voltage value is output.	No.: 1 to 40 Variable B/I/D/LB/LI/LD can be used.

2. Output voltage value

Add the following tag.

No.	Tag	Explanation	Note
2	Output voltage value	Specifies the output voltage value.	Voltage value: -14.00 to +14.00 Variable I/LI/I[]/LI[] can be used. (Units: 0.01 V)

Example

```
SET I000 1270
```

```
AOUT AO#(1) I000
```

The voltage of 12.7 V is output to the analog output port No. 1.

ARATION

Instruction set:

SUBSET	STANDARD	EXPANDED
Not available	Available	Available

Function

Starts the analog output corresponding to the speed.

ARATION is valid during linear interpolation, circular interpolation, and spline interpolation.

ARTION is carried out during playback or FWD operation, but not while operating an axis.

Construction

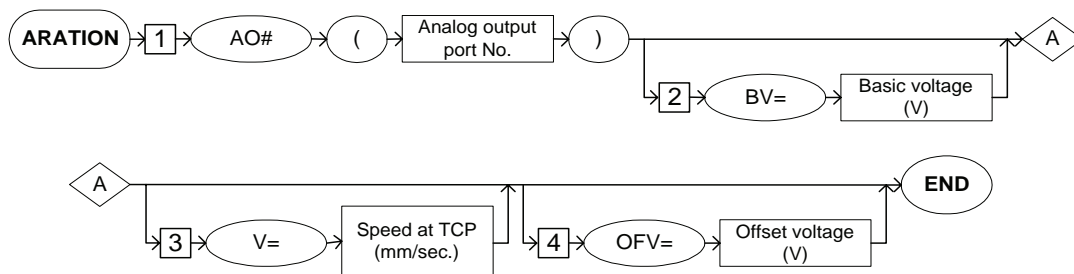

Explanation

1. AO# (Analog output port number)

Add the following tag.

No.	Tag	Explanation	Note
1	AO# (Analog output port number)	Specifies the number of the analog output port that outputs the voltage corresponding to the speed.	No.: 1 to 40 Variable B/I/D/LB/LI/LD can be used.

2. BV=Basic voltage

The following tag can be added or omitted.

No.	Tag	Explanation	Note
2	BV=Basic voltage	Specifies the voltage to be output when running at the speed set in part 3 of this Explanation.	Voltage value: -14.00 to +14.00 V Variable I/LI/I[]/LI[] can be used. (Units: 0.01 V)

3. V=Basic speed

The following tag can be added or omitted.

No.	Tag	Explanation	Note
3	V=Basic speed	Specifies the speed at which the set voltage value is output.	Speed: 0.1 to 1500.0 mm/s. Variable B/I/D/LB/LI/LD can be used. (Units: 0.1 mm/s.)

4. OFV=Offset voltage

The following tag can be added or omitted.

No.	Tag	Explanation	Note
4	OFV=Offset voltage	Specifies the analog voltage to be output at the motion speed "0".	Voltage value: -14.00 to +14.00 V Variable I/LI/I[]/LI[] can be used. (Units: 0.01 V)



Analog output function corresponding to the speed

To regulate the thickness of the sealing or paint, etc. when sealing and painting, the amount of discharged material should be adjusted according to the motion speed of the manipulator.

The analog output function corresponding to the speed automatically changes the analog output value according to the manipulator's motion speed.

ARATION and ARTIOF instructions are used to carry out this function.

On the base of the set value for the ARATION instruction, the output characteristic, which decides the relation between the motion speed and the analog voltage, is calculated. The analog output corresponding to speed is output according to this output characteristic.

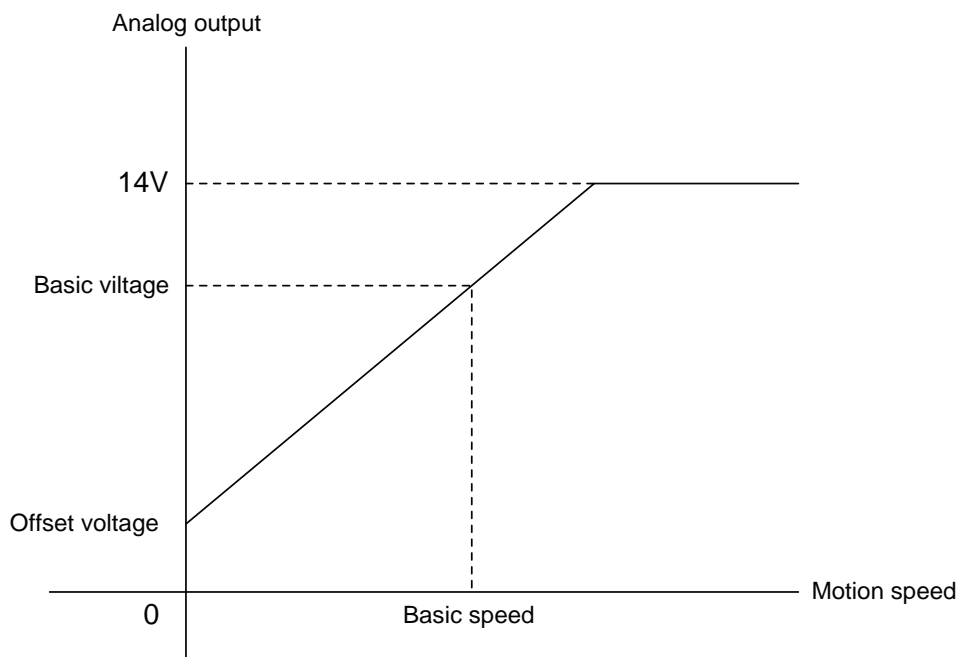

Example

MOVJ VJ=50.00	Output voltage (V)
ARATION AO#(1) BV=7.00 V=150.0 OFV=-10.0	7.00
MOVL V=50.0	-4.33
MOV C V=100.0	1.33
MOV C V=100.0	1.33
MOV C V=100.0	1.33
MOVL V=200.0	12.67

When the basic voltage is 7.00 V at a motion speed of 150.0 mm/sec for the analog output port number 1, an offset voltage of -10.0 V is output.

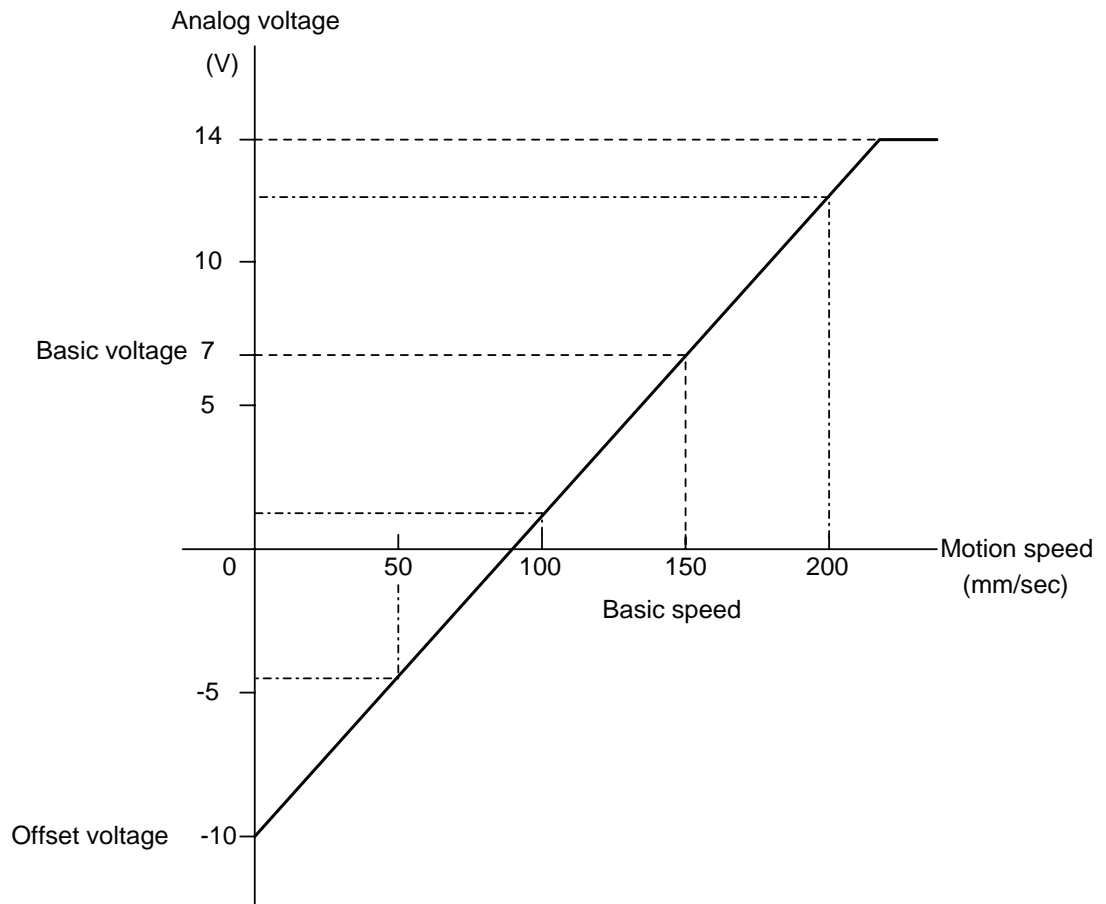

ARATIOF

Instruction set:

SUBSET	STANDARD	EXPANDED
Not available	Available	Available

Function

Cancels the analog output corresponding to the speed.

Construction

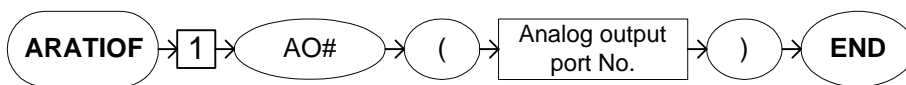

Explanation

1. AO# (Analog output port number)

Add the following tag.

No.	Tag	Explanation	Note
1	AO# (Analog output port number)	Specifies the number of the general-purpose analog output port for which the analog output corresponding to speed is to be cancelled.	No.: 1 to 40 Variable B/I/D/LB/LI/LD can be used.

Example

ARATIOF AO#(1)

The analog output corresponding to the speed at the analog output port number 1 is cancelled.

ANTOUT

The ANTOUT instruction can be used only with parameter S4C008.

Instruction set:

SUBSET	STANDARD	EXPANDED	Parameter
Not available	Available	Available	S2C508

Function

Carries out the anticipation output function to adjust the timing of the signal output.



Anticipation output function

The anticipation output function is a signal output timing adjustment function to advance or delay the ON/OFF timing of four general-purpose outputs and two general-purpose output groups. The signal can be output before or after the manipulator reaches the step.

This function corrects work timing errors due to delays in the motions of a peripheral device and/or the manipulator.

Setting the time to a negative value (-) advances the signal output.

This can be used to correct work timing errors due to delays in the motions of a peripheral device.

Setting the time to a positive value (+) delays the signal output.

This can be used to correct work timing errors due to delays in the motions of the manipulator.

Advanced signal output

The signal is output before the manipulator reaches the step.

Step	Instructions
n-1	MOVL
n	MOVL NWAIT ANTOUT AT#(1) ON
n+1	MOVL

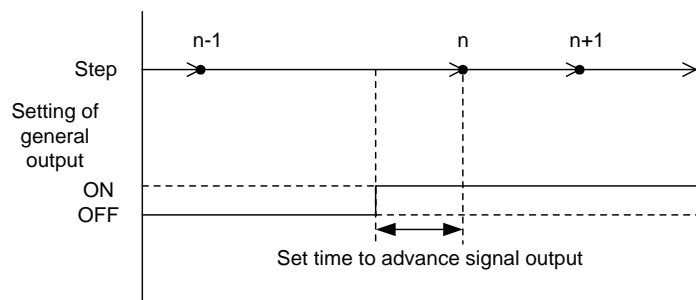

Delayed signal output

The signal is output after the manipulator reaches the step.

Step	Instructions
n-1	MOVL
n	MOVL NWAIT ANTOUT AT#(2) ON
n+1	MOVL

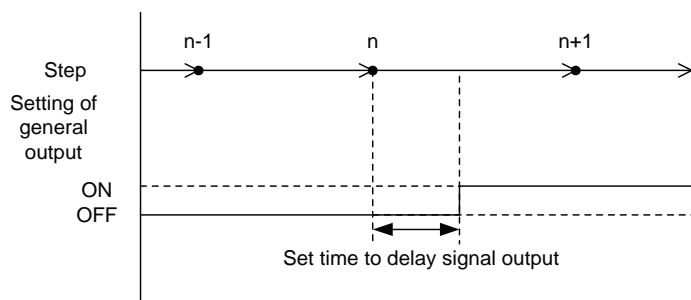

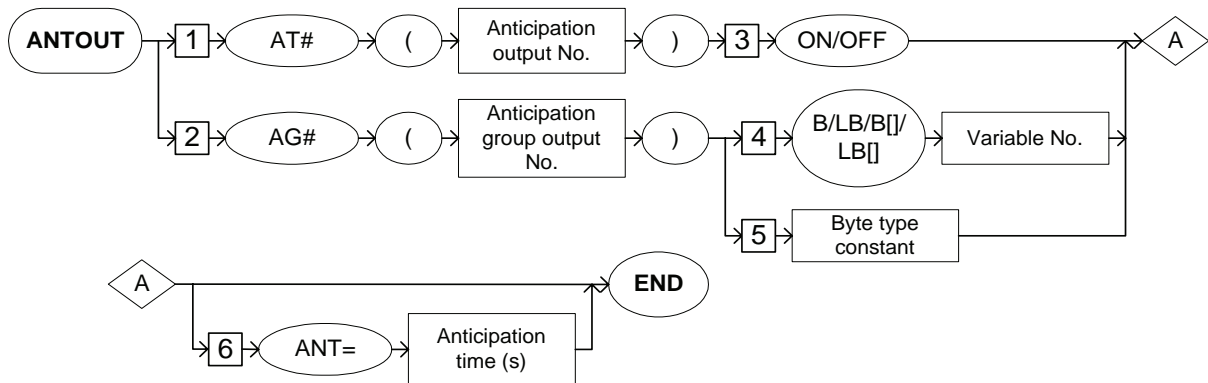
Construction**Explanation**

1. AT# (Anticipation output number) / AG# (Anticipation group output number)

Choose one of the tags from the following table.

No.	Tag	Explanation	Note
1	AT# (Anticipation output number)	Specifies the number of the signal whose timing is adjusted.	No.: 1 to 4 Variable B/I/D/LB/LI/LD can be used.
2	AG# (Anticipation group output number)	Specifies the group number of the signal whose timing is adjusted.	No.: 1 or 2 Variable B/I/D/LB/LI/LD can be used.



Settings for the anticipation output signal

Set the number of the output signal for the anticipation output in the ANTICIPATION OUTPUT display.

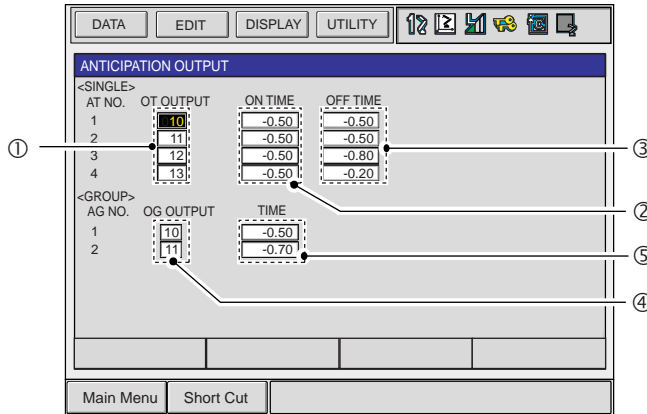

- ①OT OUTPUT (Setting range: 1 to 192)
Allocate the number of the general-purpose output whose signal timing is to be adjusted to AT NO. 1 to 4.
- ②ON TIME (Setting range: -327.68 to 327.67 seconds)
Set the delay/advance time for turning ON the signal.
- ③OFF TIME (Setting range: -327.68 to 327.67 seconds)
Set the delay/advance time for turning OFF the signal.
- ④OG OUTPUT (Setting range: 1 to 24)
Allocate the group number of the general-purpose output whose signal timing is to be adjusted to AG NO. 1 and 2.
- ⑤TIME (Setting range: -327.68 to 327.67 seconds)
Set the delay/advance time for carrying out the group output.

2. ON/OFF

When an AT#(anticipation output number) is selected from the table in part 1 of this Explanation, add the following tag.

No.	Tag	Explanation	Note
3	ON/OFF	Specifies the ON/OFF status of the signal whose output timing is adjusted.	

3. B Variable number / LB Variable number / B [Array number] / LB [Array number] / Byte type constant

When an AG#(anticipation group output number) is selected from the table in part 1 of this Explanation, choose one of the tags from the following table.

No.	Tag	Explanation	Note
4	B Variable number/ LB Variable number/ B [Array number]/ LB [Array number]	Specifies the ON/OFF status of the output signal corresponding to each bit when the contents of the specified byte type variable is expressed in bits.	Bit: 0: OFF 1: ON
5	Byte type constant	Specifies the ON/OFF status of the output signal corresponding to each bit when the contents of the specified byte type variable is expressed in bits.	

4. ANT=Anticipation time

The following tag can be added or omitted.

No.	Tag	Explanation	Note
6	ANT=Anticipation time	Specifies the delay/advance time for the output signal timing.	Units: seconds Variable I/LI/I[]/LI[] can be used. (Units: 0.01 seconds) When the time is not specified, the time set in the signal timing adjustment file is applied.

Example

Step	Instructions
n-1	MOVL V=100
n	MOVL V=100 NWAIT ANTOUT AT#(1) ON
n+1	MOVL V=100

Turns ON the general-purpose signal number 10 0.5 seconds before the manipulator reaches the step.
(Advanced signal output)

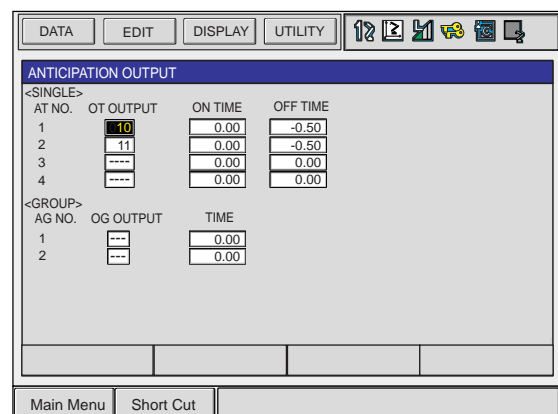

2.2 Control Instruction

JUMP

Instruction set:

SUBSET	STANDARD	EXPANDED
Available	Available	Available

Function

Jumps to specified label or job.

Construction

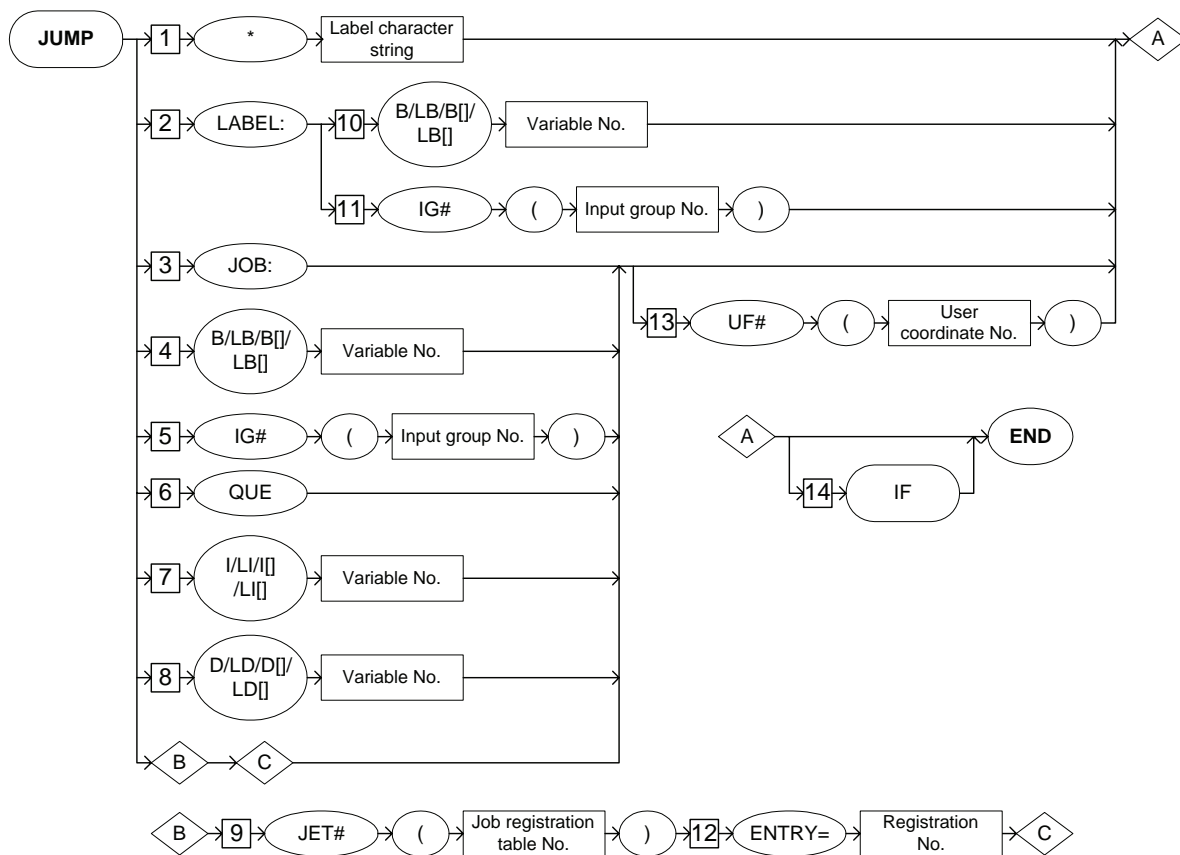

Explanation

1. *Label character string /LABEL:/JOB:/B Variable number /LB Variable number /B [Array number] /LB [Array number] /IG# (Input group number) / QUE/I Variable number/LI Variable number/I [Array number]/LI [Array number]/D Variable number/LD Variable number/ D [Array number]/LD [Array number]/ JET# (Job registration table number)

Choose one of the tags from the following table.

No	Tag	Explanation	Note
1	*Label strings	Specifies the label string.	String: eight characters
2	LABEL:	The numerical value specified by byte type variable or input group number is considered a label.	
3	JOB:	Specifies the job.	
4	B Variable number/ LB Variable number/ B [Array number]/ LB [Array number]	The numerical value specified by byte type variable is considered to be a job.	
5	IG#(Input group number)	The numerical value specified by the input group number is considered to be a job.	No.:1 to 128 Variable B/I/D/LB/LI/ LD can be used.
6	QUE	Jumps to the job stored in the queue.	Available only in the queue function (option: S2C503).
7	I Variable number/ LI Variable number/ I [Array number]/ LI [Array number]	The numerical value specified by the integer type variable is considered to be the job.	
8	D Variable number/ LD Variable number/ D [Array number]/ LD [Array number]	The numerical value specified by the double-precision type variable is considered to be the job.	
9	JET# (Job registration table number)	Specifies the job registration table number. The job of the jump destination can be registered in the job registration table.	No.: 1 to 3 Variable B/I/D/LB/LI/ LD can be used. Available only with the job registration table function (option: S2C345)

2.2 Control Instruction

2. B Variable number / LB Variable number / B [Array number] / LB [Array number] / IG# (Input group number)

When a LABEL: is selected from the table in part 1 of this Explanation, choose one of the tags from the following table.

No	Tag	Explanation	Note
10	B Variable number/ LB Variable number/ B [Array number]/ LB [Array number]	Specifies the byte type variable in which the numerical value for the label is set.	
11	IG#(Input group number)	Specifies the input group number of the numerical value for the label.	No.:1 to 128 B/I/D/LB/LI/LD Variable can be used.

3. ENTRY=Registration number

When a JET#(job registration table number) is selected from the table in part 1 of this Explanation, add the following tag.

No.	Tag	Explanation	Note
12	ENTRY=Registration number	Specifies the registration number of the job registered in the specified job registration table.	No.: 1 to 1024 Variable B/B[]/LB/ LB[]/I/I[] can be used.

4. UF# (User coordinate number)

When JOB:, B variable number, LB variable number, B [Array number], LB [Array number], IG# (Input group number), QUE, I Variable number, LI Variable number, I [Array number], LI [Array number], D Variable number, LD Variable number, D [Array number], LD [Array number], or JET# (Job registration table number) is selected from the table in part 1 of this Explanation, the following tag can be added.

No	Tag	Explanation	Note
13	UF# (User coordinate number)	Specifies the coordinates of the job.	Available only in the relative job function.

5. IF

The following tag can be added or omitted.

No	Tag	Explanation	Note
14	IF	Specifies the IF instruction.	Refer to " 2.6 Instruction Which Adheres to an Instruction ".

Example

- (1) JUMP *1
Jumps to *1.

- (2) JUMP JOB:TEST1 UF#(2)
Jumps to the job named TEST1. TEST1 works in user coordinate system No.2.

- (3) SET B000 1
JUMP B000 IF IN#(14)=ON

If input signal no.14 is on, it jumps to job "1".

CALL

Instruction set:

SUBSET	STANDARD	EXPANDED
Available	Available	Available

Function

Calls the specified job.

Construction

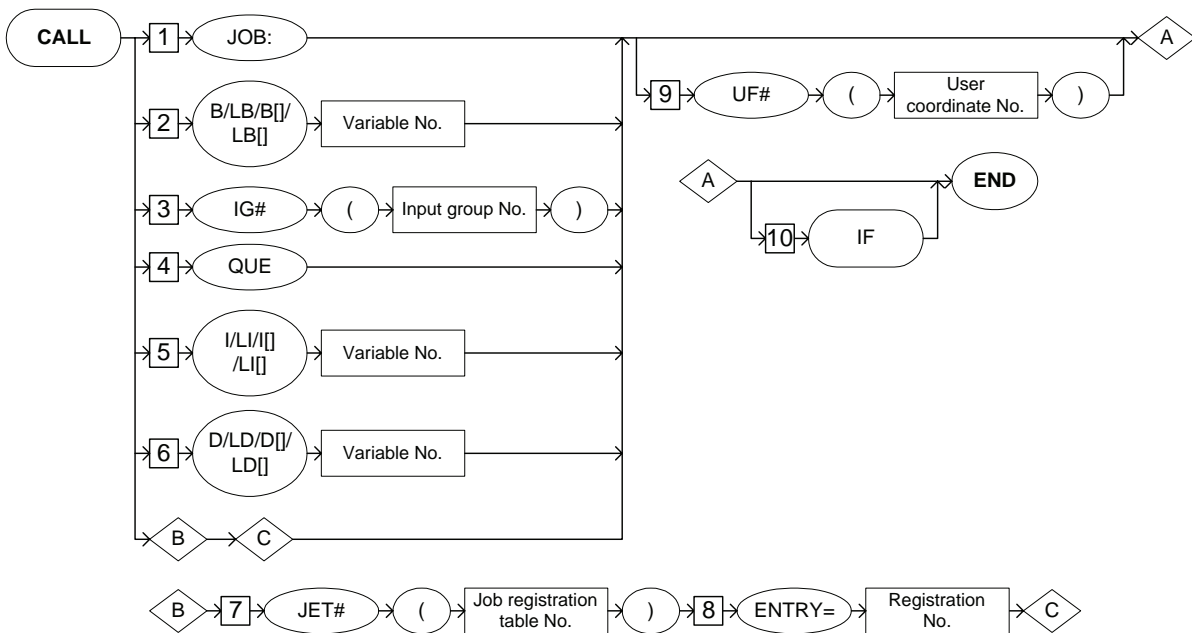

Explanation

1. JOB: / B Variable number / LB Variable number / B [Array number] / LB [Array number] / IG#(Input group number) / QUE/I Variable number/LI Variable number/I [Array number]/LI [Array number]/D Variable number/LD Variable number/ D [Array number]/LD [Array number]/ JET# (Job registration table number)

Choose one of the tags from the following table.

No	Tag	Explanation	Note
1	JOB:	Specifies any job to be called.	
2	B Variable number/ LB Variable number/ B [Array number]/ LB [Array number]	The numerical value specified in the byte type variable is considered to be the call job.	
3	IG# (Input group number)	The numerical value specified in the input group number is considered to be the call job.	No.:1 to 128 Variable B/I/D/LB/LI/ LD can be used.
4	QUE	The job stored in the queue is called.	Available only in the queue function (option: S2C503).
5	I Variable number/ LI Variable number/ I [Array number]/ LI [Array number]	The numerical value specified by the integer type variable is considered to be the call job.	
6	D Variable number/ LD Variable number/ D [Array number]/ LD [Array number]	The numerical value specified by the double-precision type variable is considered to be the call job.	
7	JET# (Job registration table number)	Specifies the table number of the job registration. The call job can be registered in the job registration table.	No.: 1 to 3 Variable B/I/D/LB/LI/ LD can be used. Available only in the job registration table function (option: S2C345)

2.2 Control Instruction

2. ENTRY=Registration number

When a JET#(job registration table number) is selected from the table in part 1 of this Explanation, add the following tag.

No.	Tag	Explanation	Note
8	ENTRY=Registration number	Specifies the registration number of the job registered in the specified job registration table.	No.: 1 to 1023 Variable B/B[]/LB/LB[]/I/I[]/LI/LI[] can be used.

3. UF# (User coordinate number)

The following tag can be added or omitted.

No	Tag	Explanation	Note
9	UF# (User coordinate number)	Specifies the user coordinate system of the job to be called.	Available only in the relative job function.

4. IF

The following tag can be added or omitted.

No	Tag	Explanation	Note
10	IF	Specifies the IF instruction.	Refer to " 2.6 Instruction Which Adheres to an Instruction ".

Example

- (1) CALL JOB:TEST1
The job named TEST1 is called.

- (2) SET B000 1
CALL B000 IF IN#(14)=ON
If input signal No.14 is on, it calls the job "1".

TIMER

Instruction set:

SUBSET	STANDARD	EXPANDED
Available	Available	Available

Function

Stops for the specified time.

Construction

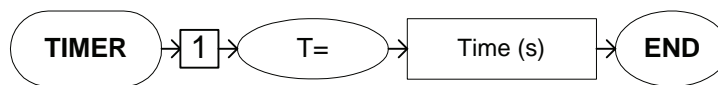

Explanation

1. T=timer

Add the following tag.

No	Tag	Explanation	Note
1	T=timer	Specifies the stopping time.	Unit: Second Variable I/LI/I[]/LI[] can be used. (Units: 0.01 seconds)

Example

- (1) TIMER T=12.50
Stops for 12.5 seconds.
- (2) SET I002 5
TIMER T=I002
Stops for 0.05 seconds.

* (LABEL)

Instruction set:

SUBSET	STANDARD	EXPANDED
Available	Available	Available

Function

Specifies the label for the jump.

Construction

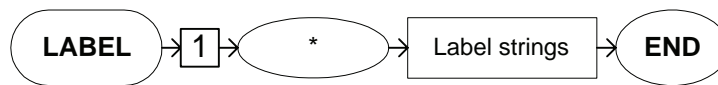

Explanation

1. *Label strings

Add the following tag.

No	Tag	Explanation	Note
1	*Label strings	Specifies the label strings.	String: 8 characters

Example

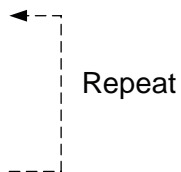

```

    NOP
    *1
    JUMP JOB:1 IF IN#(1)=ON
    JUMP JOB:2 IF IN#(2)=ON
    JUMP *1
    END
  
```

IF general input signal No.1 and No.2 are off, it loops infinitely between “*1” and “JUMP *1”.



The label is effective only in the same job. It does not jump to the same label in other jobs.

' (COMMENT)

Instruction set:

SUBSET	STANDARD	EXPANDED
Available	Available	Available

Function

Specifies the comment.

Construction



Explanation

- 'Comment strings

Add the following tag.

No	Tag	Explanation	Note
1	'Comment strings	Specifies the comment.	String: 32 characters

Example

```

NOP
'Waiting Position
MOVJ VJ=100.00
MOVJ VJ=100.00
MOVJ VJ=25.00
'Welding Start
ARCON ASF#(1)
MOVL V=138
'Welding end
ARCOF
MOVJ VJ=25.00
'Waiting Position
MOVJ VJ=100.00
END
  
```

The comment clarifies the job content.

RET

Instruction set:

SUBSET	STANDARD	EXPANDED
Available	Available	Available

Function

Returns from the called job to the original job which has been called.

Construction

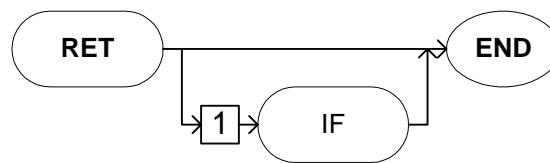

Explanation

1. IF

The following tag can be added or omitted.

No	Tag	Explanation	Note
1	IF	Specifies the IF instruction.	Refer to " 2.6 Instruction Which Adheres to an Instruction ".

Example

RET IF IN#(12)=ON

If general input signal No.12 is on, it returns to the job of the call origin.

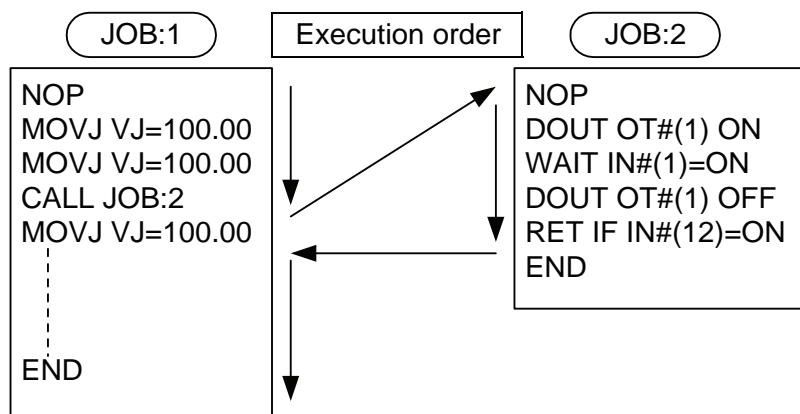

NOP

Instruction set:

SUBSET	STANDARD	EXPANDED
Not available	Available	Available

Function

Carries out no operation.

Construction

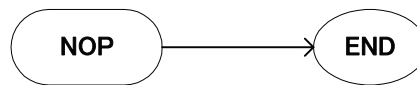

Example

```
NOP  
END
```

PAUSE

Instruction set:

SUBSET	STANDARD	EXPANDED
Not available	Available	Available

Function

Stops the job temporarily.

Construction

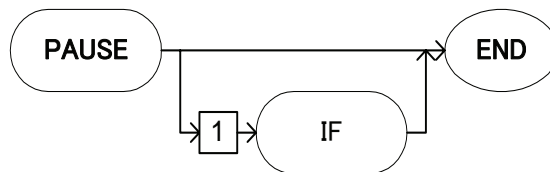

Explanation

1. IF

The following tag can be added or omitted.

No.	Tag	Explanation	Note
1	IF	Specifies an IF statement. An IF instruction states the execution conditions.	Refer to IF of “2.6 Instructions Which Adheres to Instruction”.

Example

PAUSE IF IN#(12)=ON

Stops the job temporarily if general-purpose input signal number 12 is ON.

CWAIT

Instruction set:

SUBSET	STANDARD	EXPANDED
Not available	Available	Available

Function

Waits for the next instruction line to be carried out.

CWAIT is used with the NWAIT tag, an additional item of a move instruction.

Construction

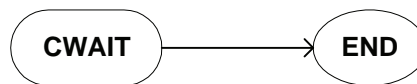

Example

<Step>	<Instructions>
n	MOVL V=100 NWAIT
	DOUT OT#(1) ON
	CWAIT
	DOUT OT#(1) OFF
n+1	MOVL V=100

Turns ON the general-purpose output signal number 1 when the manipulator starts moving from the step n to the step n+1, and turns it OFF when the manipulator reaches the step n+1.

MSG

Instruction set:

SUBSET	STANDARD	EXPANDED
Not available	Available	Available

Function

Displays the message.

Construction



Explanation

1. "Message strings"

No.	Tag	Explanation	Note
1	"Message strings"	Specifies the message.	String: 32 characters

ADVINIT

Instruction set:

SUBSET	STANDARD	EXPANDED
Not available	Not available	Available

Function

When the same variable is used for multiple systems in the optional independent control function, ADVINIT controls the timing to change the variable data among the systems. ADVINIT is an instruction used to control NX100 internal processing, therefore, executing this instruction does not affect the job.

Construction

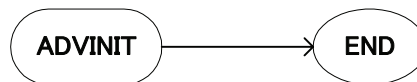

ADVSTOP

Instruction set:

SUBSET	STANDARD	EXPANDED
Not available	Available	Available

Function

When the same variable is used for multiple systems in the optional independent control function, ADVSTOP controls the access timing of the variable data among the systems. ADVSTOP is an instruction used to control NX100 internal processing, therefore, executing this instruction does not affect the job.

Construction

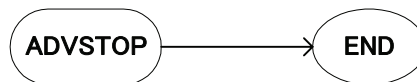

2.3 Operating Instruction

CLEAR

Instruction set:

SUBSET	STANDARD	EXPANDED
Available	Available	Available

Function

In Data 1, the variable content from the specified number on, is cleared to 0 only by the amount specified in Data 2.

Construction

CLEAR <Data 1> <Data 2>

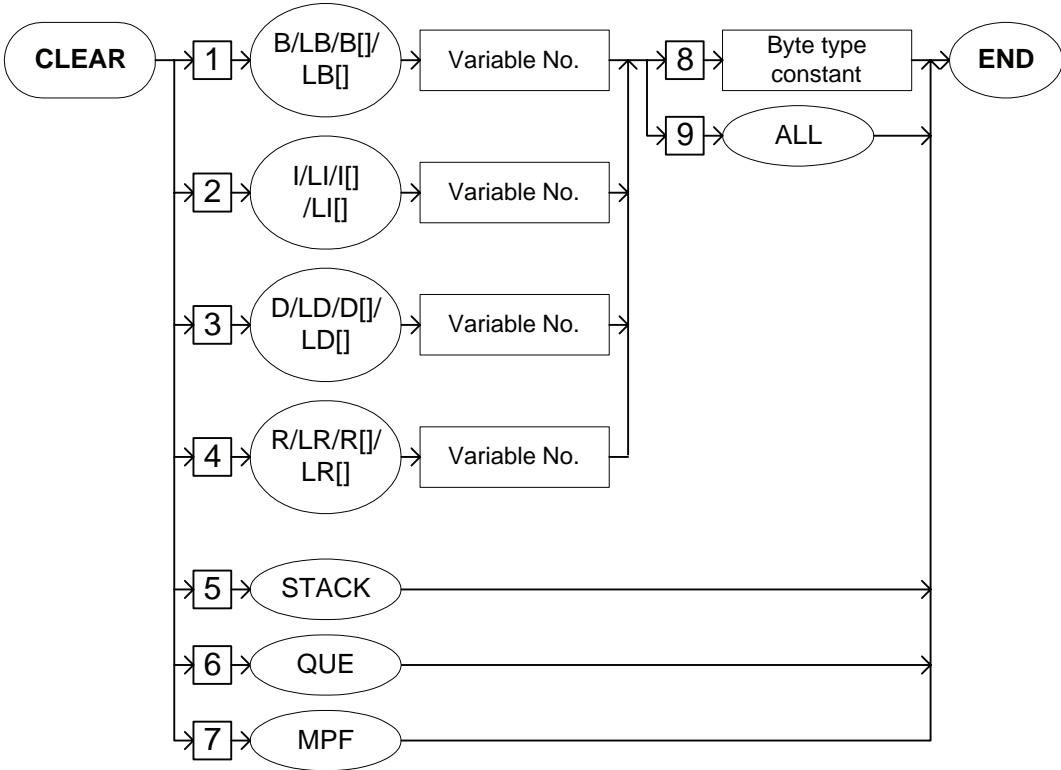

Explanation

1. B Variable number /LB Variable number /B [Array number] /LB [Array number] /I Variable number /LI Variable number /I [Array number] /LI [Array number] /D Variable number /LD Variable number /D [Array number] /LD [Array number] /R Variable number/ LR Variable number /R [Array number] /LR [Array number] /STACK/QUE/MPF

Choose one of the tags from the following table.

No	Tag	Explanation	Note
1	B Variable number/ LB Variable number/ B [Array number]/ LB [Array number]	Specifies the number of the byte type variable to be cleared.	< Data 1 >
2	I Variable number/ LI Variable number/ I [Array number]/ LI [Array number]	Specifies the number of the integer type variable to be cleared.	< Data 1 >
3	D Variable number/ LD Variable number/ D [Array number]/ LD [Array number]	Specifies the number of the double precision type variable to be cleared.	< Data 1 >
4	R Variable number/ LR Variable number/ R [Array number]/ LR [Array number]	Specifies the number of the real type variable to be cleared.	< Data 1 >
5	STACK	There are eight stacks, and they store the called position.	< Data 1 >
6	QUE	Clears all the job queues.	<Data 1> Available only with the job queue function (option: S2C503)
7	MPF	Clears all the contents of the memo play file.	<Data 1> Available only with the optional memo play function.



About the job call stack

There are eight stacks, and they store the called position.

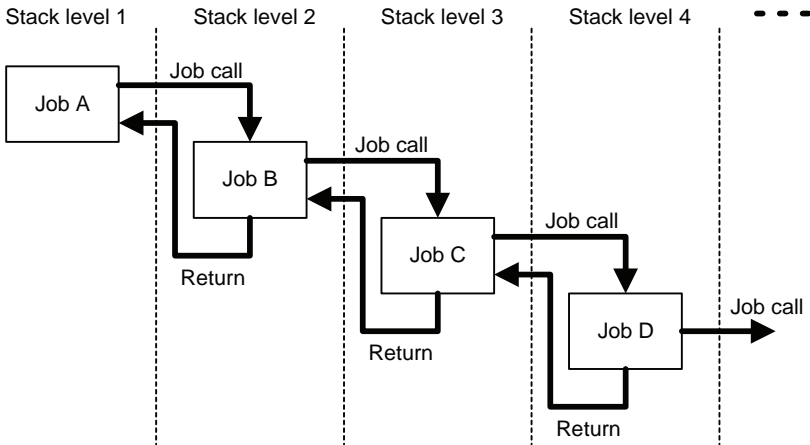

2. Byte type constant /ALL

When a B Variable number, LB Variable number, B [Array number], LB [Array number], I Variable number, LI Variable number, I [Array number], LI [Array number], D Variable number, LD Variable number, D [Array number], LD [Array number], R Variable number, LR Variable number, R [Array number], or LR [Array number] is selected from the table in part 1 of this Explanation, choose one of the tags from the following table.

No	Tag	Explanation	Note
8	Byte type constant	Specifies the number cleared starting from the number of the specified variable.	
9	ALL	All variables starting from the number of the specified variable are cleared.	

Example

- (1) CLEAR B003 10
The content of the variables from B003 to B0012 are cleared to 0.
- (2) CLEAR D010 ALL
The content of all the double precision type variables is cleared to 0 starting from D010.
- (3) CLEAR STACK
All the job call stacks are cleared.

2.3 Operating Instruction

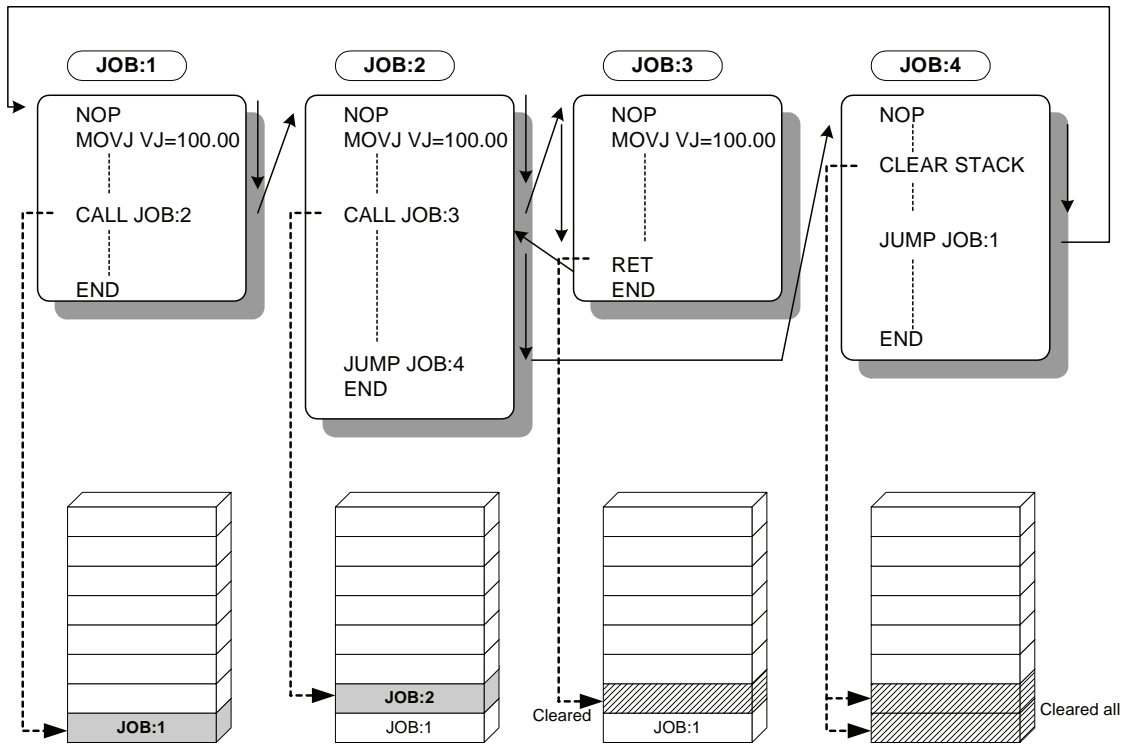

INC

Instruction set:

SUBSET	STANDARD	EXPANDED
Available	Available	Available

Function

Adds one to the content of the specified variable.

Construction

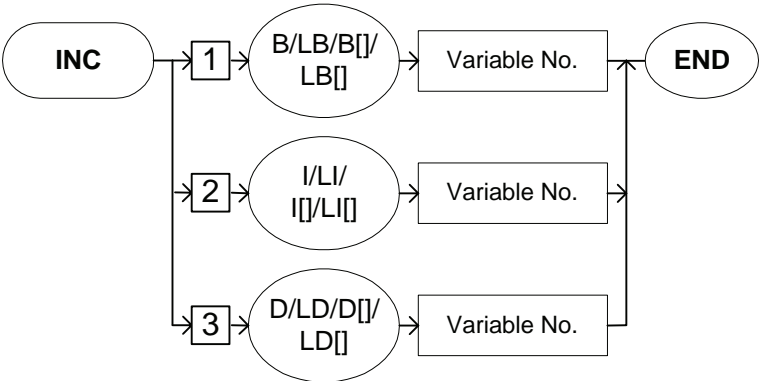

Explanation

1. B Variable number /LB Variable number /B [Array number] /LB [Array number] /I Variable number/ LI Variable number /I [Array number] /LI [Array number] /D Variable number/ LD Variable number /D [Array number] /LD [Array number]

Choose one of the tags from the following table.

No	Tag	Explanation	Note
1	B Variable number/ LB Variable number/ B [Array number]/ LB [Array number]	Specifies the number of the byte type variable.	
2	I Variable number/ LI Variable number/ I [Array number]/ LI [Array number]	Specifies the number of the integer type variable.	
3	D Variable number/ LD Variable number/ D [Array number]/ LD [Array number]	Specifies the number of the double precision type variable.	

Example

```

NOP
SET B000 0
*1 ← - - - - -
MOVJ VJ=100.00      1 is repeatedly added to B000 until it reaches 200.
MOVJ VJ=50.00
  ⋮
INC B000 ← - - - - - 1 is added to B000.
JUMP *1 IF B000<200 - - -
END
    
```

DEC

Instruction set:

SUBSET	STANDARD	EXPANDED
Not available	Available	Available

Function

Subtracts 1 from a specified variable.

Construction

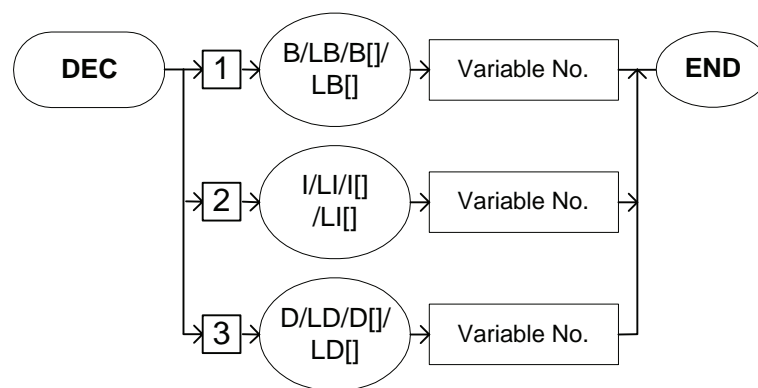

Explanation

1. B Variable number/LB Variable number/B [Array number]/LB [Array number]/I Variable number/LI Variable number/I [Array number]/LI [Array number]/ D Variable number/LD Variable number/D [Array number]/LD [Array number]

Choose one of the tags from the following table.

No.	Tag	Explanation	Note
1	B Variable number/ LB Variable number/ B [Array number]/ LB [Array number]	Specifies the number of the byte type variable from which 1 is subtracted.	
2	I Variable number/ LI Variable number/ I [Array number]/ LI [Array number]	Specifies the number of the integer type variable from which 1 is subtracted.	
3	D Variable number/ LD Variable number/ D [Array number]/ LD [Array number]	Specifies the number of the double-precision type variable from which 1 is subtracted.	

Example

```

NOP
SET B000 200
*1 ← - - - - -
MOVJ VJ=100.00
MOVJ VJ=50.00
DEC B000 ← - - - - -
JUMP *1 IF B000=0
END
```

1 is repeatedly subtracted from B000 until it reaches 0.

- - 1 is subtracted from B000.

SET

Instruction set:

SUBSET	STANDARD	EXPANDED
Available	Available	Available

Function

Sets Data 2 to Data 1.

Construction

SET <Data 1> <Data 2>

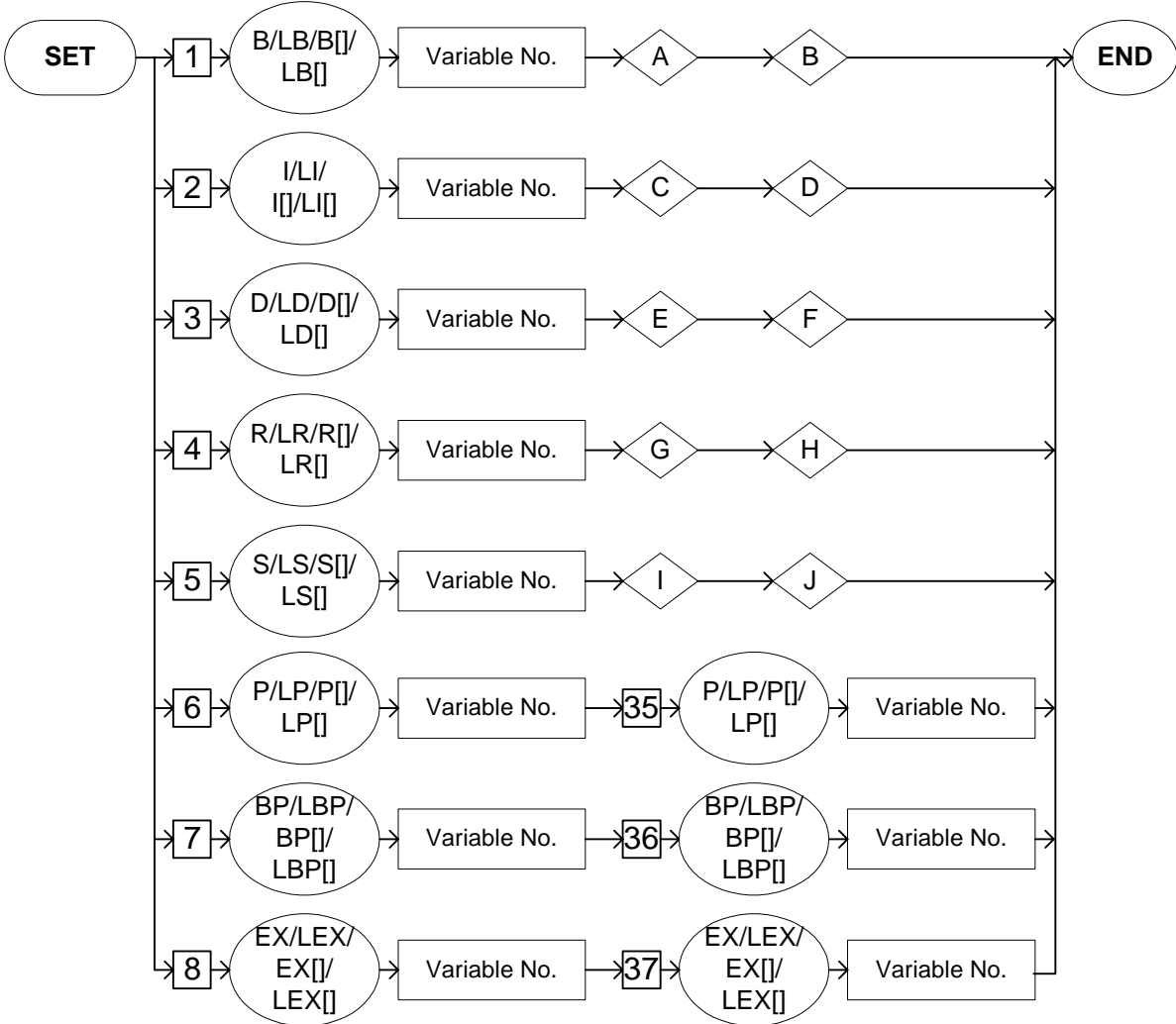

2.3 Operating Instruction

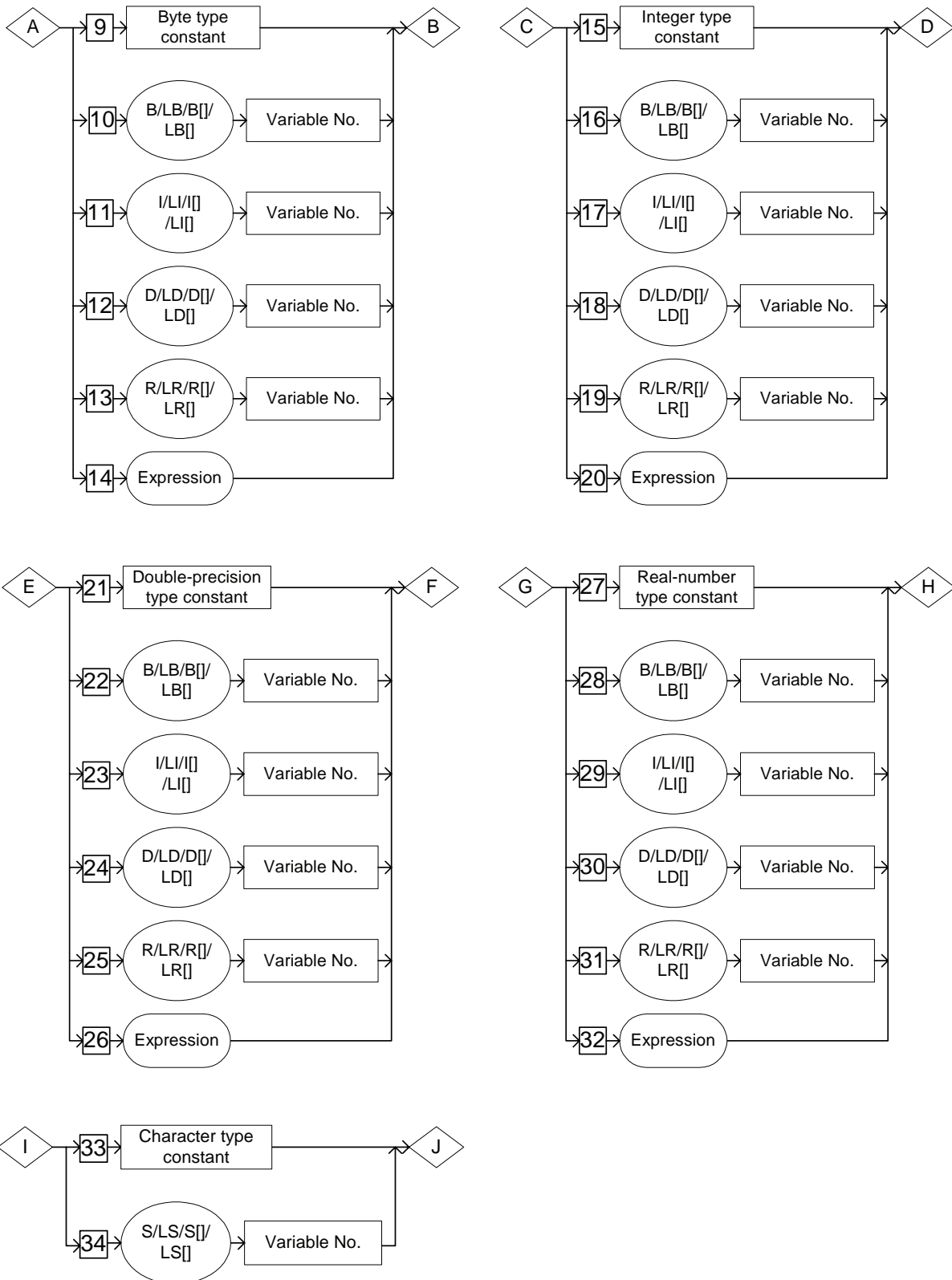

Explanation

1. B Variable number /LB Variable number /B [Array number] /LB [Array number] /I Variable number /LI Variable number /I [Array number] /LI [Array number] /D Variable number /LD Variable number /D [Array number] /LD [Array number] /R Variable number /LR Variable number /R [Array number] /LR [Array number] /S Variable number /LS Variable number /S [Array number] /LS [Array number] /P Variable number /LP Variable number /P [Array number] /LP [Array number] /BP Variable number /LBP Variable number /BP [Array number] /LBP [Array number] /EX Variable number /LEX Variable number /EX [Array number] /LEX [Array number]

Choose one of the tags from the following table.

No	Tag	Explanation	Note
1	B Variable number/ LB Variable number/ Ba[Array number]/ LBa[Array number]	Specifies the number of the byte type variable to which data is set.	< Data1>
2	I Variable number/ LI Variable number/ I [Array number]/ LI [Array number]	Specifies the number of the integer type variable to which data is set.	< Data 1>
3	D Variable number/ LD Variable number/ Da[Array number]/ LDa[Array number]	Specifies the number of the double precision type variable to which data is set.	< Data 1>
4	R Variable number/ LR Variable number/ R [Array number]/ LR [Array number]	Specifies the number of the real type variable to which data is set.	< Data 1>
5	S Variable number/ LS Variable number/ S [Array number]/ LS [Array number]	Specifies the number of the character type variable to which data is set.	< Data 1>

2.3 Operating Instruction

No	Tag	Explanation	Note
6	P Variable number/ LP Variable number/ P [Array number]/ LP [Array number]	Specifies the number of the robot axis positional variable to which data is set.	< Data 1 >
7	BP Variable number/ LBP Variable number/ BP [Array number]/ LBP [Array number]	Specifies the number of the base axis positional variable to which data is set.	< Data 1 >
8	EX Variable number/ LEX Variable number/ EX [Array number]/ LEX [Array number]	Specifies the number of the station axis positional variable to which data is set.	< Data 1 >

2. Byte type constant /B Variable number /LB Variable number /B [Array number] /LB [Array number] /I Variable number /LI Variable number /I [Array number] /LI [Array number] /D Variable number /LD Variable number /D [Array number] /LD [Array number] /R Variable number /LR Variable number /R [Array number] /LR [Array number]/Expression

When a B Variable number, LB Variable number, B [Array number], or LB [Array number] is selected from the table part 1 of this Explanation, choose one of the tags from the following table.

No	Tag	Explanation	Note
9	Byte type constant	Specifies the byte type constant.	< Data 2 >
10	B Variable number/ LB Variable number/ B [Array number]/ LB [Array number]	Specifies the number of the byte type variable.	< Data 2 >

No	Tag	Explanation	Note
11	I Variable number/ LI Variable number/ I [Array number]/ LI [Array number]	Specifies the number of the integer type variable.	< Data 2>
12	D Variable number/ LD Variable number/ D [Array number]/ LD [Array number]	Specifies the number of the double precision type variable.	< Data 2>
13	R Variable number/ LR Variable number/ R [Array number]/ LR [Array number]	Specifies the number of the real type variable.	< Data 2>
14	Expression	Specifies the expression.	<Data 2> For details of setting the expression, refer to "1.4 Registration of Expression".

3. Integer type constant /B Variable number /LB Variable number /B [Array number] /LB [Array number] /I Variable number /LI Variable number /I [Array number] /LI [Array number] /D Variable number /LD Variable number /D [Array number] /LD [Array number] /R Variable number /LR Variable number /R [Array number] /LR [Array number]/Expression

When an I Variable number, LI Variable number, I [Array number], or LI [Array number] is selected from the table in part 1 of this Explanation, choose one of the tags from the following table.

No	Tag	Explanation	Note
15	Integer type constant	Specifies the integer type constant.	< Data 2>
16	B Variable number/ LB Variable number/ B [Array number]/ LB [Array number]	Specifies the number of the byte type variable.	< Data 2>

2.3 Operating Instruction

No	Tag	Explanation	Note
17	I Variable number/ LI Variable number/ I [Array number]/ LI [Array number]	Specifies the number of the integer type variable.	< Data 2>
18	D Variable number/ LD Variable number/ D [Array number]/ LD [Array number]	Specifies the number of the double precision type variable.	< Data 2>
19	R Variable number/ LR Variable number/ R [Array number]/ LR [Array number]	Specifies the number of the real type variable.	< Data 2>
20	Expression	Specifies the expression.	<Data 2> For details of setting the expression, refer to "1.4 Registration of Expression".

4. Double precision type constant /B Variable number /LB Variable number / B [Array number] /LB [Array number] /I Variable number /LI Variable number /I [Array number] /LI [Array number] /D Variable number /LD Variable number /D [Array number] /LD [Array number] /R Variable number /LR Variable number /R [Array number] /LR [Array number]/Expression

When a D Variable number, LD Variable number, D [Array number], or LD [Array number] is selected from the table in part 1 of this Explanation, choose one of the tags from the following table.

No	Tag	Explanation	Note
21	Double precision type constant	Specifies the double precision type constant.	< Data 2>
22	B Variable number/ LB Variable number/ B [Array number]/ LB [Array number]	Specifies the number of the byte type variable.	< Data 2>

No	Tag	Explanation	Note
23	I Variable number/ LI Variable number/ I [Array number]/ LI [Array number]	Specifies the number of the integer type variable.	< Data 2>
24	D Variable number/ LD Variable number/ D [Array number]/ LD [Array number]	Specifies the number of the double precision type variable.	< Data 2>
25	R Variable number/ LR Variable number/ R [Array number]/ LR [Array number]	Specifies the number of the real type variable.	< Data 2>
26	Expression	Specifies the expression.	<Data 2> For details of setting the expression, refer to "1.4 Registration of Expression".

5. Real type constant /B Variable number /LB Variable number /B [Array number] /LB [Array number] /I Variable number /LI Variable number /I [Array number] /LI [Array number] /D Variable number /LD Variable number /D [Array number] /LD [Array number] /R Variable number /LR Variable number /R [Array number] /LR [Array number]/Expression

When an R Variable number, LR Variable number, R [Array number], or LR [Array number] is selected from the table in part 1 of this Explanation, choose one of the tags from the following table.

No	Tag	Explanation	Note
27	Real type constant	Specifies the real type constant.	< Data 2>
28	B Variable number/ LB Variable number/ B [Array number]/ LB [Array number]	Specifies the number of the byte type variable.	< Data2>

2.3 Operating Instruction

No	Tag	Explanation	Note
29	I Variable number/ LI Variable number/ I[Array number]/ LI [Array number]	Specifies the number of the integer type variable.	< Data 2>
30	D Variable number/ LD Variable number/ D [Array number]/ LD [Array number]	Specifies the number of the double precision type variable.	< Data 2>
31	R Variable number/ LR Variable number/ R [Array number]/ LR [Array number]	Specifies the number of the real type variable.	< Data 2>
32	Expression	Specifies the expression.	<Data 2> For details of setting the expression, refer to "1.4 Registration of Expression".

6. Character type constant /S Variable number /LS Variable number /S [Array number] /LS [Array number]

When an S Variable number, LS Variable number, S [Array number], or LS [Array number] is selected from the table in part 1 of this Explanation, choose one of the tags from the following table.

No	Tag	Explanation	Note
33	Character type constant	Specifies the character type data.	< Data 2>
34	S Variable number/ LS Variable number/ S [Array number]/ LS [Array number]	Specifies the number of the character type variable.	< Data 2>

7. P Variable number /LP Variable number /P [Array number] /LP [Array number]

When a P Variable number, LP Variable number, P [Array number], or LP [Array number] is selected from the table in part 1 of this Explanation, add the following tag.

No	Tag	Explanation	Note
35	P Variable number/ LP Variable number/ P [Array number]/ LP [Array number]	Specifies the number of the robot axis position variable.	< Data 2>

8. BP Variable number /LBP Variable number /BP [Array number] /LBP [Array number]

When a BP Variable number, LBP Variable number, BP [Array number], or LBP [Array number] is selected from the table in part 1 of this Explanation, add the following tag.

No	Tag	Explanation	Note
36	BP Variable number/ LBP Variable number/ BP [Array number]/ LBP [Array number]	Specifies the number of the base axis position variable.	< Data 2>

9. EX Variable number /LEX Variable number /EX [Array number] /LEX [Array number]

When an EX Variable number, LEX Variable number, EX [Array number], or LEX [Array number] is selected from the table in part 1 of this Explanation, add the following tag.

No	Tag	Explanation	Note
37	EX Variable number/ LEX Variable number/ EX [Array number]/ LEX [Array number]	Specifies the number of the station axis position variable.	< Data 2>

2.3 Operating Instruction

Example

- (1) SET B000 0
0 is set in B000.

- (2) SET P000 P001
The content of P001 is set in P000.

ADD

Instruction set:

SUBSET	STANDARD	EXPANDED
Not available	Available	Available

Function

Adds Data 1 and Data 2, and stores the result in Data 1.

Construction

Add <Data 1> <Data 2>

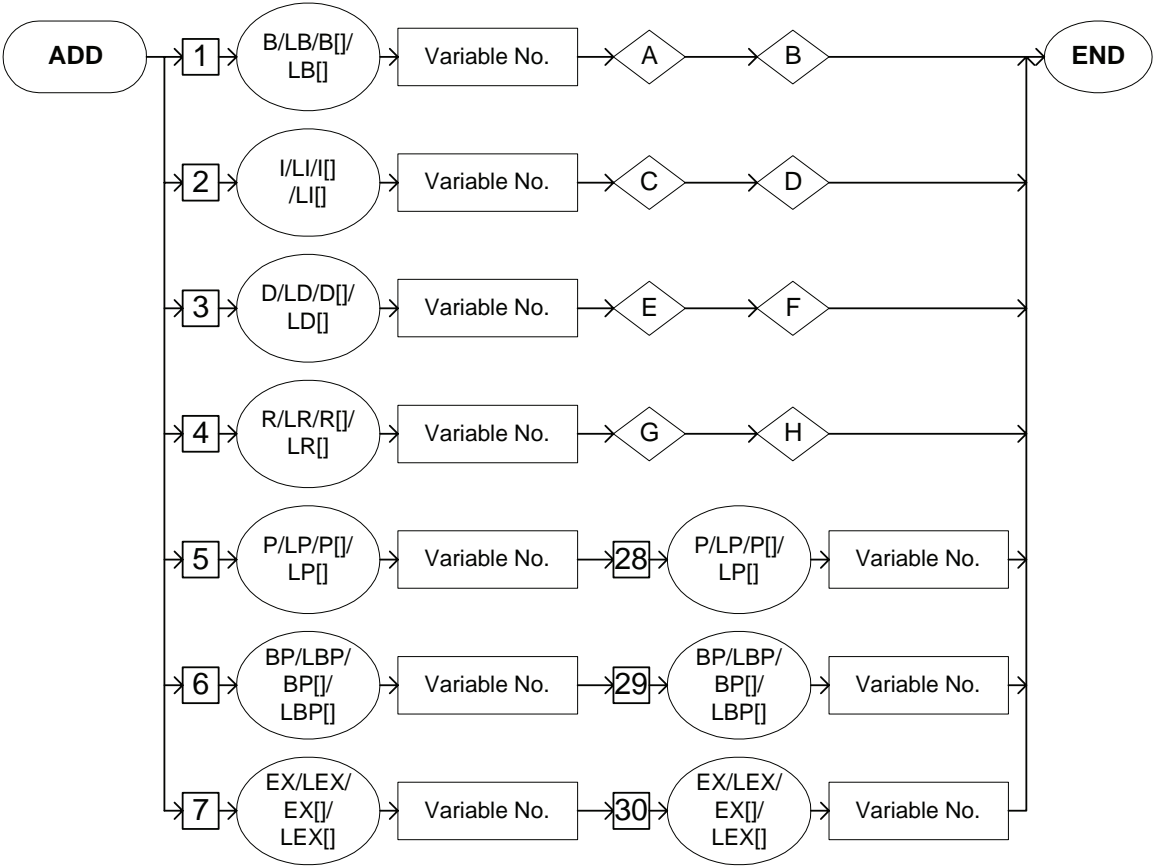

2.3 Operating Instruction

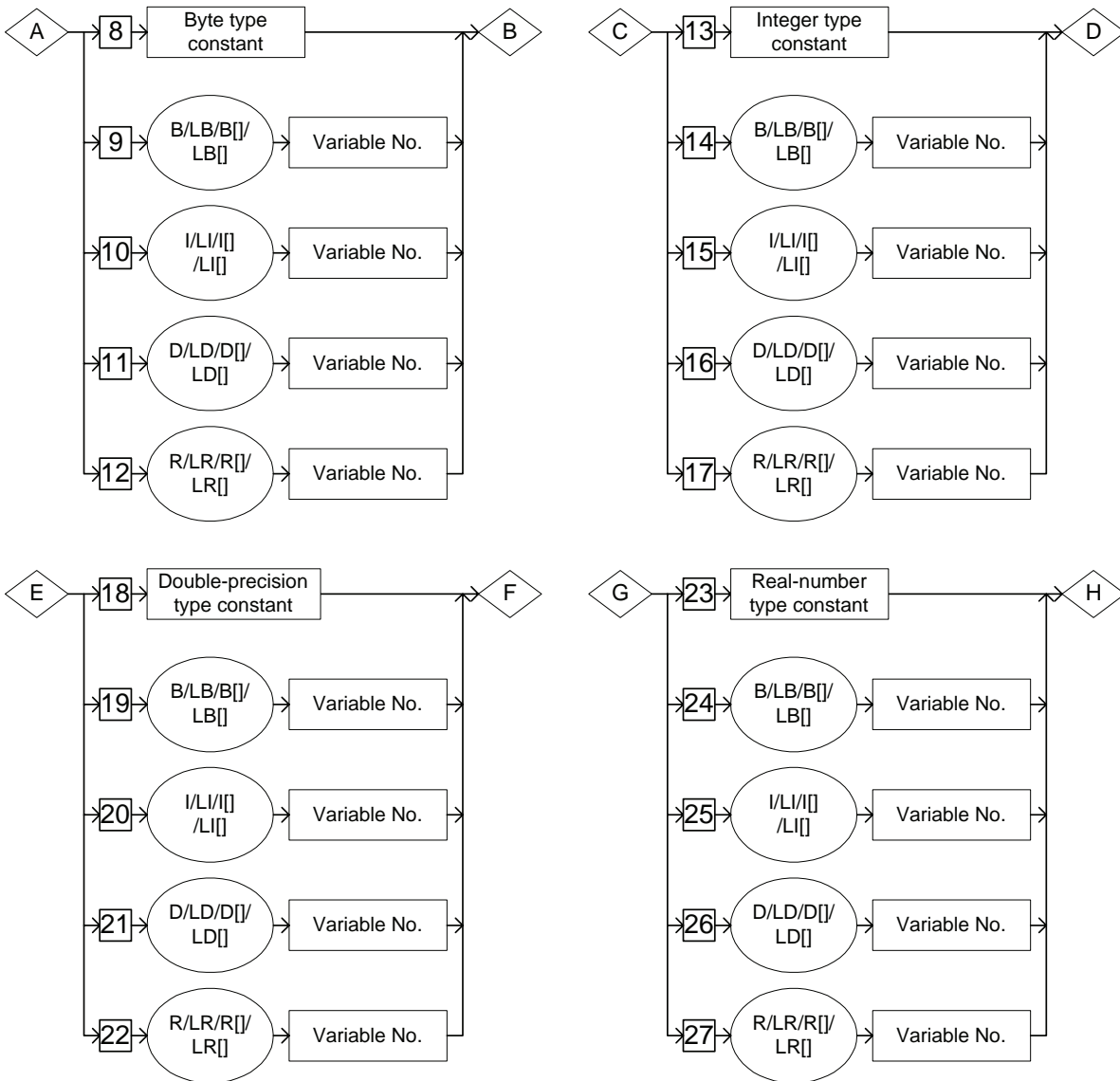

Explanation

1. B Variable number/LB Variable number/B [Array number]/LB [Array number]/I Variable number/LI Variable number/I [Array number]/LI [Array number]/D Variable number/LD Variable number/D [Array number]/LD [Array number]/R Variable number/LR Variable number/R [Array number]/LR [Array number]/P Variable number/LP Variable number/P [Array number]/LP [Array number]/BP Variable number/LBP Variable number/BP [Array number]/LBP [Array number]/EX Variable number/LEX Variable number/EX [Array number]/LEX [Array number]

Choose one of the tags from the following table.

No.	Tag	Explanation	Note
1	B Variable number/ LB Variable number/ B [Array number]/ LB [Array number]	Specifies the number of the byte type variable to be added.	<Data 1>
2	I Variable number/ LI Variable number/ I [Array number]/ LI [Array number]	Specifies the number of the integer type variable to be added.	<Data 1>
3	D Variable number/ LD Variable number/ D [Array number]/ LD [Array number]	Specifies the number of the double-precision type variable to be added.	<Data 1>
4	R Variable number/ LR Variable number/ R [Array number]/ LR [Array number]	Specifies the number of the real-number type variable to be added.	<Data 1>
5	P Variable number/ LP Variable number/ P [Array number]/ LP [Array number]	Specifies the number of the robot axis position type variable to be added.	<Data 1>
6	BP Variable number/ LBP Variable number/ BP [Array number]/ LBP [Array number]	Specifies the number of the base axis position type variable to be added.	<Data 1>
7	EX Variable number/ LEX Variable number/ EX [Array number]/ LEX [Array number]	Specifies the number of the station axis position type variable to be added.	<Data 1>

2.3 Operating Instruction

2. Byte type constant/B Variable number/LB Variable number/B [Array number]/LB [Array number]/I Variable number/LI Variable number/I [Array number]/LI [Array number]/D Variable number/LD Variable number/D [Array number]/LD [Array number]/R Variable number/LR Variable number/R [Array number]/LR [Array number]

When a B Variable number, LB Variable number, B [Array number], or LB [Array number] is selected from the table in part 1 of this Explanation, choose one of the tags from the following table.

No.	Tag	Explanation	Note
8	Byte type constant	Specifies the byte type data to be added.	<Data 2>
9	B Variable number/LB Variable number/ B [Array number]/ LB [Array number]	Specifies the number of the byte type variable to be added.	<Data 2>
10	I Variable number/LI Variable number/ I [Array number]/ LI [Array number]	Specifies the number of the integer type variable to be added.	<Data 2>
11	D Variable number/LD Variable number/ D [Array number]/ LD [Array number]	Specifies the number of the double-precision type variable to be added.	<Data 2>
12	R Variable number/LR Variable number/ R [Array number]/ LR [Array number]	Specifies the number of the real-number type variable to be added.	<Data 2>

3. Integer type constant/B Variable number/LB Variable number/B [Array number]/LB [Array number]/I Variable number/LI Variable number/I [Array number]/LI [Array number]/D Variable number/LD Variable number/D [Array number]/LD [Array number]/R Variable number/LR Variable number/R [Array number]/LR [Array number]

When an I Variable number, LI Variable number, I [Array number], or LI [Array number] is selected from the table in part 1 of this Explanation, choose one of the tags from the following table.

No.	Tag	Explanation	Note
13	Integer type constant	Specifies the integer type data to be added.	<Data 2>
14	B Variable number/LB Variable number/ B [Array number]/ LB [Array number]	Specifies the number of the byte-type variable to be added.	<Data 2>
15	I Variable number/LI Variable number/ I [Array number]/ LI [Array number]	Specifies the number of the integer type variable to be added.	<Data 2>
16	D Variable number/LD Variable number/ D [Array number]/ LD [Array number]	Specifies the number of the double-precision type variable to be added.	<Data 2>
17	R Variable number/LR Variable number/ R [Array number]/ LR [Array number]	Specifies the number of the real-number type variable to be added.	<Data 2>

2.3 Operating Instruction

4. Double-precision type constant/B Variable number/LB Variable number/B [Array number]/LB [Array number]/I Variable number/LI Variable number/I [Array number]/LI [Array number]/D Variable number/LD Variable number/D [Array number]/LD [Array number]/R Variable number/LR Variable number/R [Array number]/LR [Array number]

When a D Variable number, LD Variable number, D [Array number], or LD [Array number] is selected from the table in part 1 of this Explanation, choose one of the tags from the following table.

No.	Tag	Explanation	Note
18	Double-precision type constant	Specifies the double-precision type data to be added.	<Data 2>
19	B Variable number/LB Variable number/ B [Array number]/ LB [Array number]	Specifies the number of the byte type variable to be added.	<Data 2>
20	I Variable number/LI Variable number/ I [Array number]/ LI [Array number]	Specifies the number of the integer type variable to be added.	<Data 2>
21	D Variable number/LD Variable number/ D [Array number]/ LD [Array number]	Specifies the number of the double-precision type variable to be added.	<Data 2>
22	R Variable number/LR Variable number/ R [Array number]/ LR [Array number]	Specifies the number of the real-number type variable to be added.	<Data 2>

5. Real-number type constant/B Variable number/LB Variable number/B [Array number]/LB [Array number]/I Variable number/LI Variable number/I [Array number]/LI [Array number]/D Variable number/LD Variable number/D [Array number]/LD [Array number]/R Variable number/LR Variable number/R [Array number]/LR [Array number]

When an R Variable number, LR Variable number, R [Array number]. or LR [Array number] is selected from the table in part 1 of this Explanation, choose one of the tags from the following table.

No.	Tag	Explanation	Note
23	Real-number type constant	Specifies the real-number type data to be added.	<Data 2>
24	B Variable number/LB Variable number/ B [Array number]/ LB [Array number]	Specifies the number of the byte type variable to be added.	<Data 2>
25	I Variable number/LI Variable number/ I [Array number]/ LI [Array number]	Specifies the number of the integer type variable to be added.	<Data 2>
26	D Variable number/LD Variable number/ D [Array number]/ LD [Array number]	Specifies the number of the double-precision type variable to be added.	<Data 2>
27	R Variable number/LR Variable number/ R [Array number]/ LR [Array number]	Specifies the number of the real-number type variable to be added.	<Data 2>

2.3 Operating Instruction

6. P Variable number/LP Variable number/P [Array number]/LP [Array number]

When a P Variable number, LP Variable number, P [Array number], or LP [Array number] is selected from the table in part 1 of this Explanation, add the following tag.

No.	Tag	Explanation	Note
28	P Variable number/ LP Variable number/ P [Array number]/ LP [Array number]	Specifies the number of the robot axis position type variable to be added.	<Data 2>

7. BP Variable number/LBP Variable number/BP [Array number]/LBP [Array number]

When a BP Variable number, LBP Variable number, BP [Array number], or LBP [Array number] is selected from the table in part 1 of this Explanation, add the following tag.

No.	Tag	Explanation	Note
29	BP Variable number/ LBP Variable number/ BP [Array number]/ LBP [Array number]	Specifies the number of the base axis position type variable to be added.	<Data 2>

8. EX Variable number/LEX Variable number/EX [Array number]/LEX [Array number]

When an EX Variable number, LEX Variable number, EX [Array number], or LEX [Array number] is selected from the table in part 1 of this Explanation, add the following tag.

No	Tag	Explanation	Note
30	EX Variable number/ LEX Variable number/ EX [Array number]/ LEX [Array number]	Specifies the number of the station axis position type variable to be added.	<Data 2>

Example

- (1) ADD B000 10
Adds 10 to B000, and stores the result in B000.

- (2) ADD I000 I001
Adds I001 to I000, and stores the result in I000.

- (3) ADD P000 P001
Adds P001 to P000, and stores the result in P000.

SUB

Instruction set:

SUBSET	STANDARD	EXPANDED
Not available	Available	Available

Function

Subtracts Data 2 from Data 1, and stores the result in Data 1.

Construction

SUB <Data 1> <Data 2>

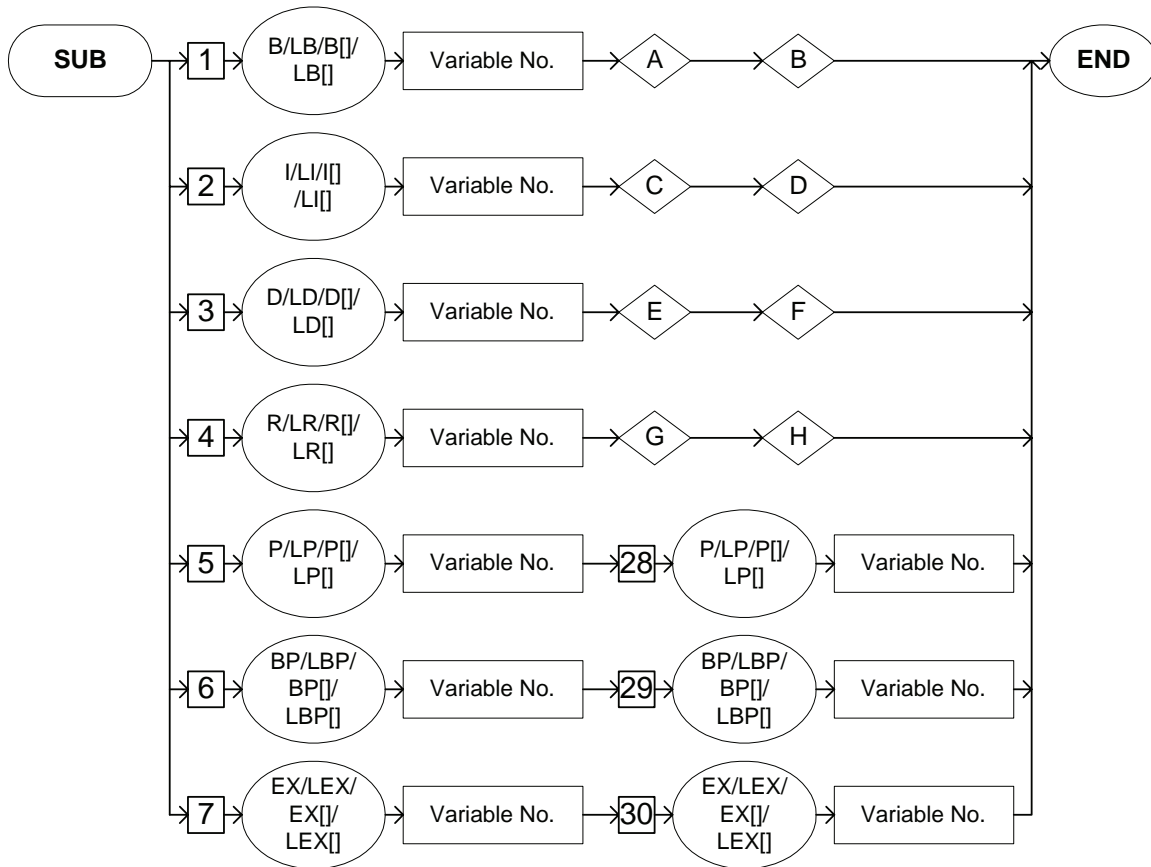

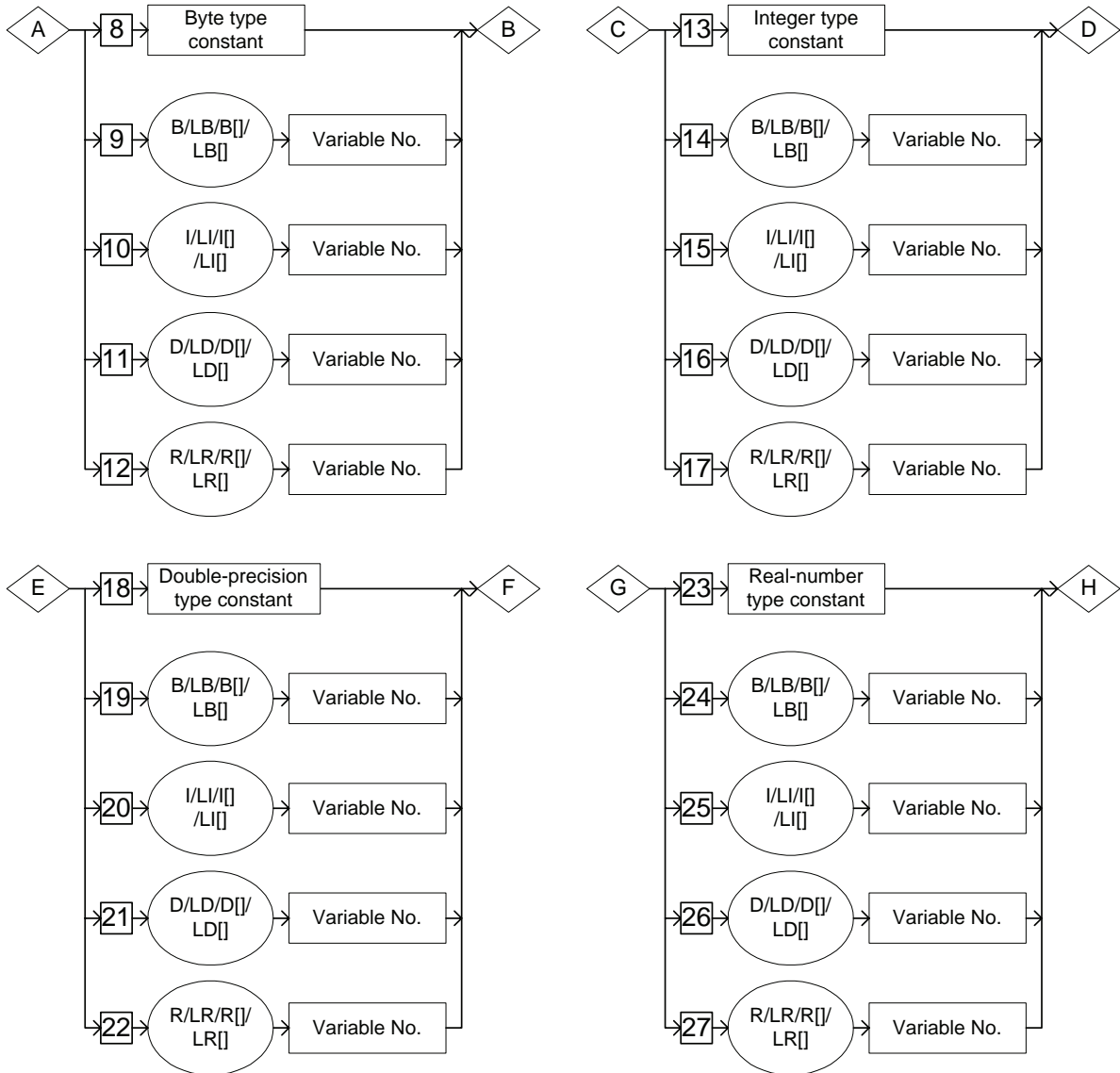

Explanation

1. B Variable number/LB Variable number/B [Array number]/LB [Array number]/I Variable number/LI Variable number/I [Array number]/LI [Array number]/D Variable number/LD Variable number/D [Array number]/LD [Array number]/R Variable number/LR Variable number/R [Array number]/LR [Array number]/P Variable number/LP Variable number/P [Array number]/LP [Array number]/BP Variable number/LBP Variable number/BP [Array number]/LBP [Array number]/EX Variable number/LEX Variable number/EX [Array number]/LEX [Array number]

Choose one of the tags from the following table.

No.	Tag	Explanation	Note
1	B Variable number/ LB Variable number/ B [Array number]/ LB [Array number]	Specifies the number of the byte type variable to be subtracted.	<Data 1>
2	I Variable number/ LI Variable number/ I [Array number]/ LI [Array number]	Specifies the number of the integer type variable to be subtracted.	<Data 1>
3	D Variable number/ LD Variable number/ D [Array number]/ LD [Array number]	Specifies the number of the double-precision type variable to be subtracted.	<Data 1>
4	R Variable number/ LR Variable number/ R [Array number]/ LR [Array number]	Specifies the number of the real-number type variable to be subtracted.	<Data 1>
5	P Variable number/ LP Variable number/ P [Array number]/ LP [Array number]	Specifies the number of the robot axis position type variable to be subtracted.	<Data 1>

No.	Tag	Explanation	Note
6	BP Variable number/ LBP Variable number/ BP [Array number]/ LBP [Array number]	Specifies the number of the base axis position type variable to be subtracted.	<Data 1>
7	EX Variable number/ LEX Variable number/ EX [Array number]/ LEX [Array number]	Specifies the number of the station axis position type variable to be subtracted.	<Data 1>

2.3 Operating Instruction

2. Byte type constant/B Variable number/LB Variable number/B [Array number]/LB [Array number]/I Variable number/LI Variable number/I [Array number]/LI [Array number]/D Variable number/LD Variable number/D [Array number]/LD [Array number]/R Variable number/LR Variable number/R [Array number]/LR [Array number]

When a B Variable number, LB Variable number, B [Array number], or LB [Array number] is selected from the table in part 1 of this Explanation, choose one of the tags from the following table.

No.	Tag	Explanation	Note
8	Byte type constant	Specifies the byte type data to be subtracted.	<Data 2>
9	B Variable number/ LB Variable number/ B [Array number]/ LB [Array number]	Specifies the number of the byte type variable to be subtracted.	<Data 2>
10	I Variable number/ LI Variable number/ I [Array number]/ LI [Array number]	Specifies the number of the integer type variable to be subtracted.	<Data 2>
11	D Variable number/ LD Variable number/ D [Array number]/ LD [Array number]	Specifies the number of the double-precision type variable to be subtracted.	<Data 2>
12	R Variable number/ LR Variable number/ R [Array number]/ LR [Array number]	Specifies the number of the real-number type variable to be subtracted.	<Data 2>

3. Integer type constant/B Variable number/LB Variable number/B [Array number]/LB [Array number]/I Variable number/LI Variable number/I [Array number]/LI [Array number]/D Variable number/LD Variable number/D [Array number]/LD [Array number]/R Variable number/LR Variable number/R [Array number]/LR [Array number]

When an I Variable number, LI Variable number, I [Array number], or LI [Array number] is selected from the table part 1 of this Explanation, choose one of the tags from the following table.

No.	Tag	Explanation	Note
13	Integer type constant	Specifies the integer type data to be subtracted.	<Data 2>
14	B Variable number/ LB Variable number/ B [Array number]/ LB [Array number]	Specifies the number of the byte type variable to be subtracted.	<Data 2>
15	I Variable number/ LI Variable number/ I [Array number]/ LI [Array number]	Specifies the number of the integer type variable to be subtracted.	<Data 2>
16	D Variable number/ LD Variable number/ D [Array number]/ LD [Array number]	Specifies the number of the double-precision type variable to be subtracted.	<Data 2>
17	R Variable number/ LR Variable number/ R [Array number]/ LR [Array number]	Specifies the number of the real-number type variable to be subtracted.	<Data 2>

2.3 Operating Instruction

4. Double-precision type constant/B Variable number/LB Variable number/B [Array number]/LB [Array number]/I Variable number/LI Variable number/I [Array number]/LI [Array number]/D Variable number/LD Variable number/D [Array number]/LD [Array number]/R Variable number/LR Variable number/R [Array number]/LR [Array number]

When a D Variable number, LD Variable number, D [Array number], or LD [Array number] is selected from the table in part 1 of this Explanation, choose one of the tags from the following table.

No.	Tag	Explanation	Note
18	Double-precision type constant	Specifies the double-precision type data to be subtracted.	<Data 2>
19	B Variable number/ LB Variable number/ B [Array number]/ LB [Array number]	Specifies the number of the byte type variable to be subtracted.	<Data 2>
20	I Variable number/ LI Variable number/ I [Array number]/ LI [Array number]	Specifies the number of the integer type variable to be subtracted.	<Data 2>
21	D Variable number/ LD Variable number/ D [Array number]/ LD [Array number]	Specifies the number of the double-precision type variable to be subtracted.	<Data 2>
22	R Variable number/ LR Variable number/ R [Array number]/ LR [Array number]	Specifies the number of the real-number type variable to be subtracted.	<Data 2>

5. Real-number type constant/B Variable number/LB Variable number/B [Array number]/LB [Array number]/I Variable number/LI Variable number/I [Array number]/LI [Array number]/D Variable number/LD Variable number/D [Array number]/LD [Array number]/R Variable number/LR Variable number/R [Array number]/LR [Array number]

When an R Variable number, LR Variable number, R [Array number], or LR [Array number] is selected from the table in part 1 of this Explanation, choose one of the tags from the following table.

No.	Tag	Explanation	Note
23	Real-number type constant	Specifies the real-number type data to be subtracted.	<Data 2>
24	B Variable number/ LB Variable number/ B [Array number]/ LB [Array number]	Specifies the number of the byte type variable to be subtracted.	<Data 2>
25	I Variable number/ LI Variable number/ I [Array number]/ LI [Array number]	Specifies the number of the integer type variable to be subtracted.	<Data 2>
26	D Variable number/ LD Variable number/ D [Array number]/ LD [Array number]	Specifies the number of the double-precision type variable to be subtracted.	<Data 2>
27	R Variable number/ LR Variable number/ R [Array number]/ LR [Array number]	Specifies the number of the real-number type variable to be subtracted.	<Data 2>

2.3 Operating Instruction

6. P Variable number/LP Variable number/P [Array number]/LP [Array number]

When a P Variable number, LP Variable number, P [Array number], or LP [Array number] is selected from the table in part 1 of this Explanation, add the following tag.

No.	Tag	Explanation	Note
28	P Variable number/ LP Variable number/ P [Array number]/ LP [Array number]	Specifies the number of the robot axis position type variable to be subtracted.	<Data 2>

7. BP Variable number/LBP Variable number/BP [Array number]/LBP [Array number]

When a BP Variable number, LBP Variable number, BP [Array number], or LBP [Array number] is selected from the table in part 1 of this Explanation, add the following tag.

No.	Tag	Explanation	Note
29	BP Variable number/ LBP Variable number/ BP [Array number]/ LBP [Array number]	Specifies the number of the base axis position type variable to be subtracted.	<Data 2>

8. EX Variable number/LEX Variable number/EX [Array number]/LEX [Array number]

When an EX Variable number, LEX Variable number, EX [Array number], or LEX [Array number] is selected from the table in part 1 of this Explanation, add the following tag.

No.	Tag	Explanation	Note
30	EX Variable number/ LEX Variable number/ EX [Array number]/ LEX [Array number]	Specifies the number of the station axis position type variable to be subtracted.	<Data 2>

Example

- (1) SUB B000 10
Subtracts 10 from B000, and stores the result in B000.

- (2) SUB I000 I001
Subtracts I001 from I000, and stores the result in I000.

- (3) SUB P000 P001
Subtracts P001 from P000, and stores the result in P000.

MUL

Instruction set:

SUBSET	STANDARD	EXPANDED
Not available	Available	Available

Function

Multiplies Data 1 by Data 2, and stores the result in Data 1.

Construction

MUL <Data 1> <Data 2>

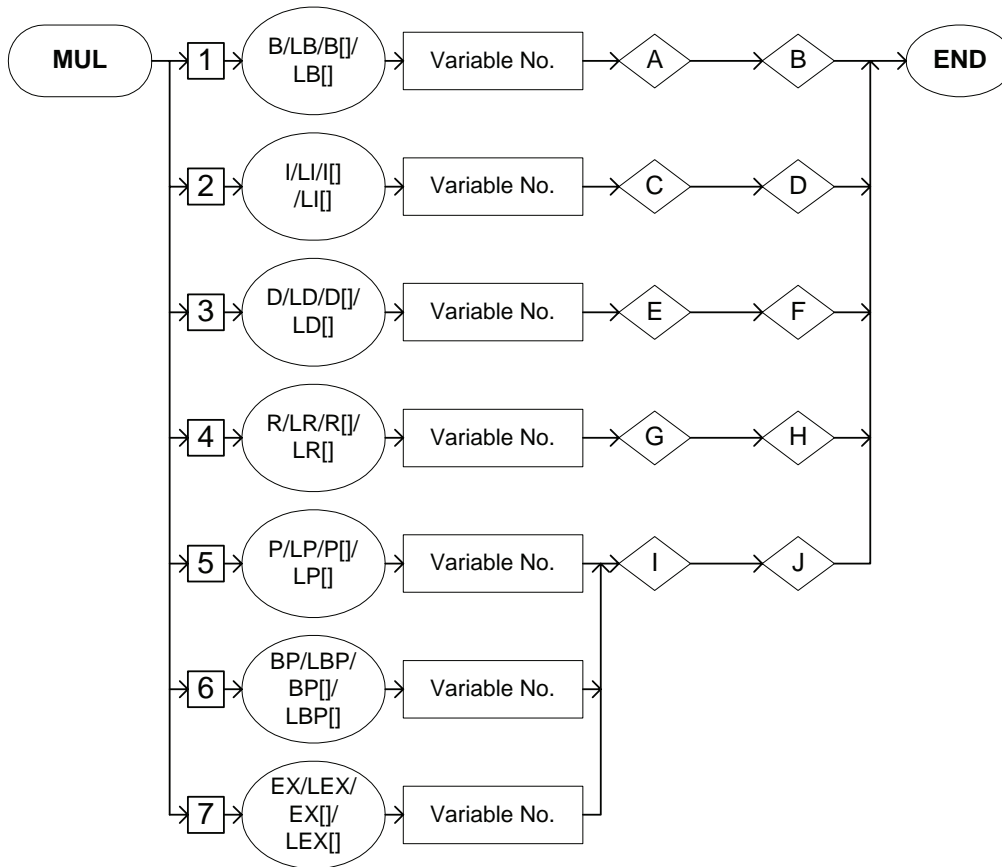

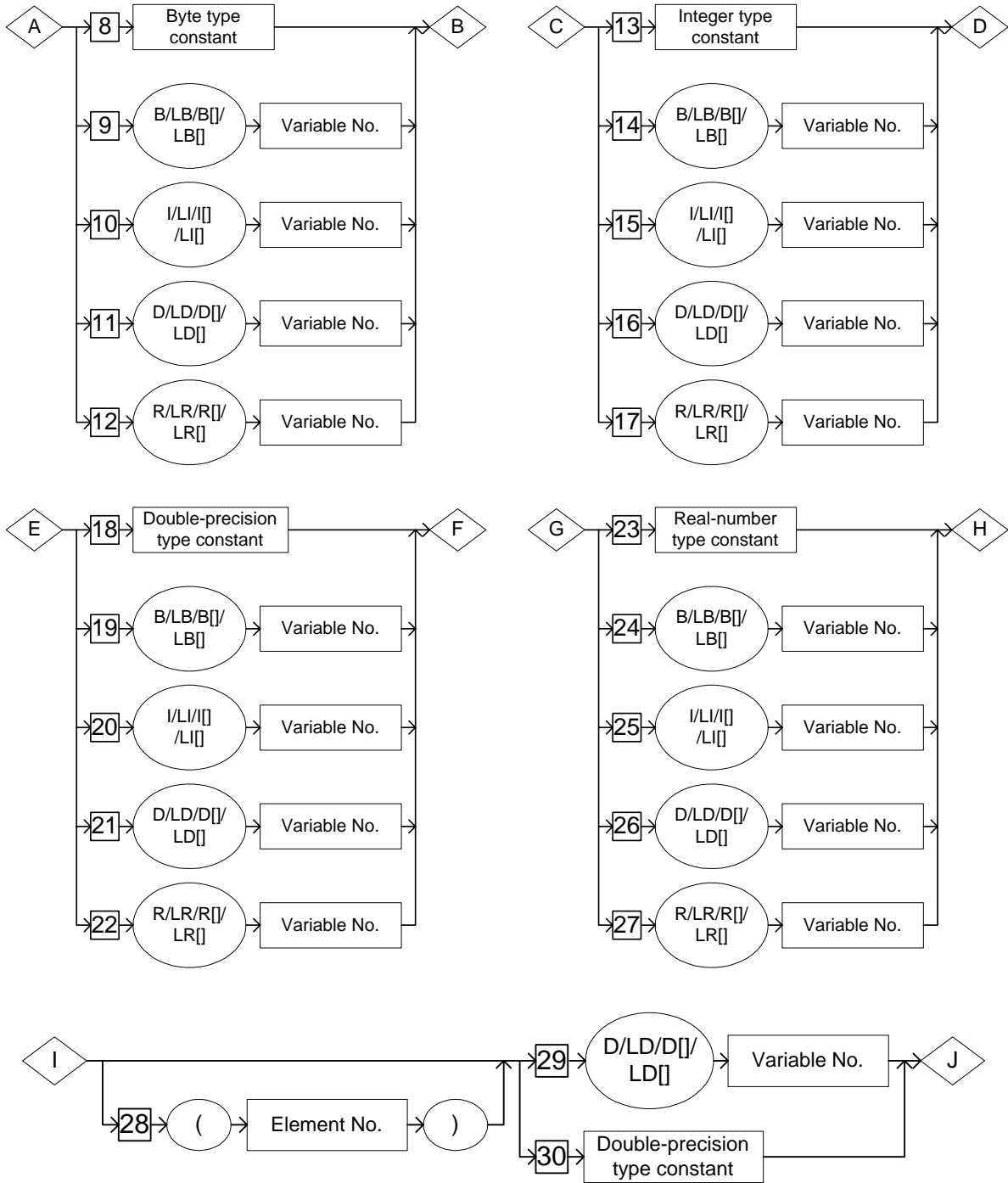

Explanation

1. B Variable number/LB Variable number/B [Array number]/LB [Array number]/I Variable number/LI Variable number/I [Array number]/LI [Array number]/D Variable number/LD Variable number/D [Array number]/LD [Array number]/R Variable number/LR Variable number/R [Array number]/LR [Array number]/P Variable number/LP Variable number/P [Array number]/LP [Array number]/BP Variable number/LBP Variable number/BP [Array number]/LBP [Array number]/EX Variable number/LEX Variable number/EX [Array number]/LEX [Array number]

Choose one of the tags from the following table.

No.	Tag	Explanation	Note
1	B Variable number/ LB Variable number B [Array number]/ LB [Array number]	Specifies the number of the byte type variable to be multiplied.	<Data 1>
2	I Variable number/ LI Variable number/ I [Array number]/ LI [Array number]	Specifies the number of the integer type variable to be multiplied.	<Data 1>
3	D Variable number/ LD Variable number/ D [Array number]/ LD [Array number]	Specifies the number of the double-precision type variable to be multiplied.	<Data 1>
4	R Variable number/ LR Variable number/ R [Array number]/ LR [Array number]	Specifies the number of the real-number type variable to be multiplied.	<Data 1>
5	P Variable number/ LP Variable number/ P [Array number]/ LP [Array number]	Specifies the number of the robot axis position type variable to be multiplied.	<Data 1>

No.	Tag	Explanation	Note
6	BP Variable number/ LBP Variable number/ BP [Array number]/ LBP [Array number]	Specifies the number of the base axis position type variable to be multiplied.	<Data 1>
7	EX Variable number/ LEX Variable number/ EX [Array number]/ LEX [Array number]	Specifies the number of the station axis position type variable to be multiplied.	<Data 1>

2.3 Operating Instruction

2. Byte type constant/B Variable number/LB Variable number/B [Array number]/LB [Array number]/I Variable number/LI Variable number/I [Array number]/LI [Array number]/D Variable number/LD Variable number/D [Array number]/LD [Array number]/R Variable number/LR Variable number/R [Array number]/LR [Array number]

When a B Variable number, LB Variable number, B [Array number], or LB [Array number] is selected from the table in part 1 of this Explanation, choose one of the tags from the following table.

No.	Tag	Explanation	Note
8	Byte type constant	Specifies the byte type data to be multiplied.	<Data 2>
9	B Variable number/ LB Variable number/ B [Array number]/ LB [Array number]	Specifies the number of the byte type variable to be multiplied.	<Data 2>
10	I Variable number/ LI Variable number/ I [Array number]/ LI [Array number]	Specifies the number of the integer type variable to be multiplied.	<Data 2>
11	D Variable number/ LD Variable number/ D [Array number]/ LD [Array number]	Specifies the number of the double-precision type variable to be multiplied.	<Data 2>
12	R Variable number/ LR Variable number/ R [Array number]/ LR [Array number]	Specifies the number of the real-number type variable to be multiplied.	<Data 2>

3. Integer type constant/B Variable number/LB Variable number/B [Array number]/LB [Array number]/I Variable number/LI Variable number/I [Array number]/LI [Array number]/D Variable number/LD Variable number/D [Array number]/LD [Array number]/R Variable number/LR Variable number/R [Array number]/LR [Array number]

When an I Variable number, LI Variable number, I [Array number], or LI [Array number] is selected from the table in part 1 of this Explanation, choose one of the tags from the following table.

No.	Tag	Explanation	Note
13	Integer type constant	Specifies the integer type data to be multiplied.	<Data 2>
14	B Variable number/ LB Variable number/ B [Array number]/ LB [Array number]	Specifies the number of the byte type variable to be multiplied.	<Data 2>
15	I Variable number/ LI Variable number/ I [Array number]/ LI [Array number]	Specifies the number of the integer type variable to be multiplied.	<Data 2>
16	D Variable number/ LD Variable number/ D [Array number]/ LD [Array number]	Specifies the number of the double-precision type variable to be multiplied.	<Data 2>
17	R Variable number/ LR Variable number/ R [Array number]/ LR [Array number]	Specifies the number of the real-number type variable to be multiplied.	<Data 2>

2.3 Operating Instruction

4. Double-precision type constant/B Variable number/LB Variable number/B [Array number]/LB [Array number]/I Variable number/LI Variable number/I [Array number]/LI [Array number]/D Variable number/LD Variable number/D [Array number]/LD [Array number]/R Variable number/LR Variable number/R [Array number]/LR [Array number]

When a D Variable number, LD Variable number, D [Array number], or LD [Array number] is selected from the table in part 1 of this Explanation, choose one of the tags from the following table.

No.	Tag	Explanation	Note
18	Double-precision type constant	Specifies the double-precision type data to be multiplied.	<Data 2>
19	B Variable number/ LB Variable number/ B [Array number]/ LB [Array number]	Specifies the number of the byte type variable to be multiplied.	<Data 2>
20	I Variable number/ LI Variable number/ I [Array number]/ LI [Array number]	Specifies the number of the integer type variable to be multiplied.	<Data 2>
21	D Variable number/ LD Variable number/ D [Array number]/ LD [Array number]	Specifies the number of the double-precision type variable to be multiplied.	<Data 2>
22	R Variable number/ LR Variable number/ R [Array number]/ LR [Array number]	Specifies the number of the real-number type variable to be multiplied.	<Data 2>

5. Real-number type constant/B Variable number/LB Variable number/B [Array number]/LB [Array number]/I Variable number/LI Variable number/I [Array number]/LI [Array number]/D Variable number/LD Variable number/D [Array number]/LD [Array number]/R Variable number/LR Variable number/R [Array number]/LR [Array number]

When an R Variable number, LR Variable number, R [Array number], or LR [Array number] is selected from the table in part 1 of this Explanation, choose one of the tags from the following table.

No.	Tag	Explanation	Note
23	Real-number type constant	Specifies the real-number type data to be multiplied.	<Data 2>
24	B Variable number/ LB Variable number/ B [Array number]/ LB [Array number]	Specifies the number of the byte type variable to be multiplied.	<Data 2>
25	I Variable number/ LI Variable number/ I [Array number]/ LI [Array number]	Specifies the number of the integer type variable to be multiplied.	<Data 2>
26	D Variable number/ LD Variable number/ D [Array number]/ LD [Array number]	Specifies the number of the double-precision type variable to be multiplied.	<Data 2>
27	R Variable number/ LR Variable number/ R [Array number]/ LR [Array number]	Specifies the number of the real-number type variable to be multiplied.	<Data 2>

6. (Element number)

When a P Variable number, LP Variable number, P [Array number], LP [Array number], BP Variable number, LBP Variable number, BP [Array number], LBP [Array number], EX Variable number, LEX Variable number, EX [Array number], or LEX [Array number] is selected from the table in part 1 of this Explanation, the following tag can be added or omitted.

No.	Tag	Explanation	Note
28	(Element number)	Specifies the element of the position type variable to be multiplied. If omitted, all the elements of the position type variable are specified.	Element number: 1 to 255 Variable B/LB can be used.



Element of position type variable

The element of position type variable differs depending on the type of variable as follows.

- Robot axis position type variable

<Pulse type>

(1): 1st axis data, (2): 2nd axis data, (3): 3rd axis data, (4) 4th axis data,
(5): 5th axis data, (6) 6th axis data, (7): 7th axis data, (8): 8th axis data

<XYZ type>

(1): X axis data, (2): Y axis data, (3) Z axis data,
(4): Tx axis data, (5): Ty axis data, (6): Tz axis data

- Base axis position type variable

(1): 1st axis data, (2): 2nd axis data •••

- Station axis position type variable

(1): 1st axis data, (2): 2nd axis data •••

7. D Variable number/LD Variable number/D [Array number]/LD [Array number]/ Double-precision type constant

When a P Variable number, LP Variable number, P [Array number], LP [Array number], BP Variable number, LBP Variable number, BP [Array number], LBP [Array number], EX Variable number, LEX Variable number, EX [Array number], or LEX [Array number] is selected from the table in part 1 of this Explanation, choose one of the tags from the following table after (Element number) of 6.

No.	Tag	Explanation	Note
29	D Variable number/ LD Variable number/ D [Array number]/ LD [Array number]	Specifies the number of the double-precision variable by which the element of position type variable is multiplied.	<Data 2>
30	Double-precision type constant	Specifies the double-precision type data by which the element of position type variable is multiplied.	<Data 2>

Example

- (1) MUL B000 10
Multiplies B000 by 10, and stores the result in B000.
- (2) MUL I000 I001
Multiplies I000 by I001, and stores the result in I000.
- (3) SET D000 2
MUL P000 (3) D000
Multiplies the Z axis data of P000 by D000 (D000=2), and stores the result in P000.

DIV

Instruction set:

SUBSET	STANDARD	EXPANDED
Not available	Available	Available

Function

Divides Data 1 by Data 2, and stores the result in Data 1.

Construction

DIV <Data 1> <Data 2>

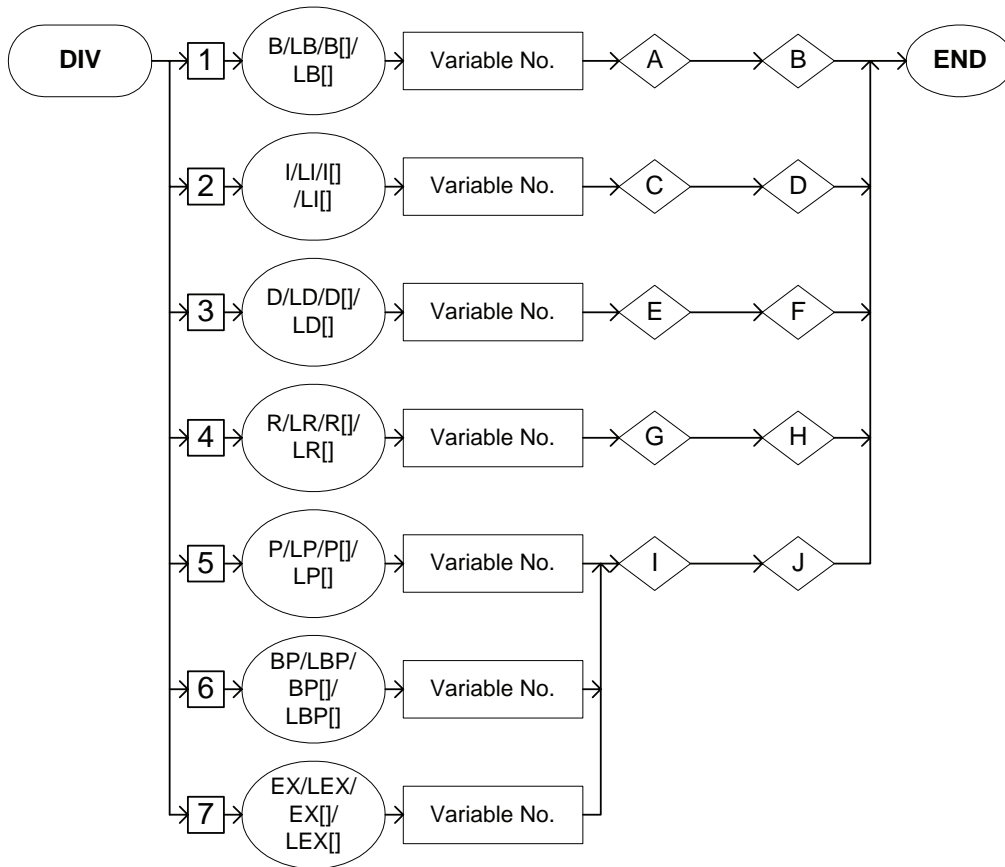

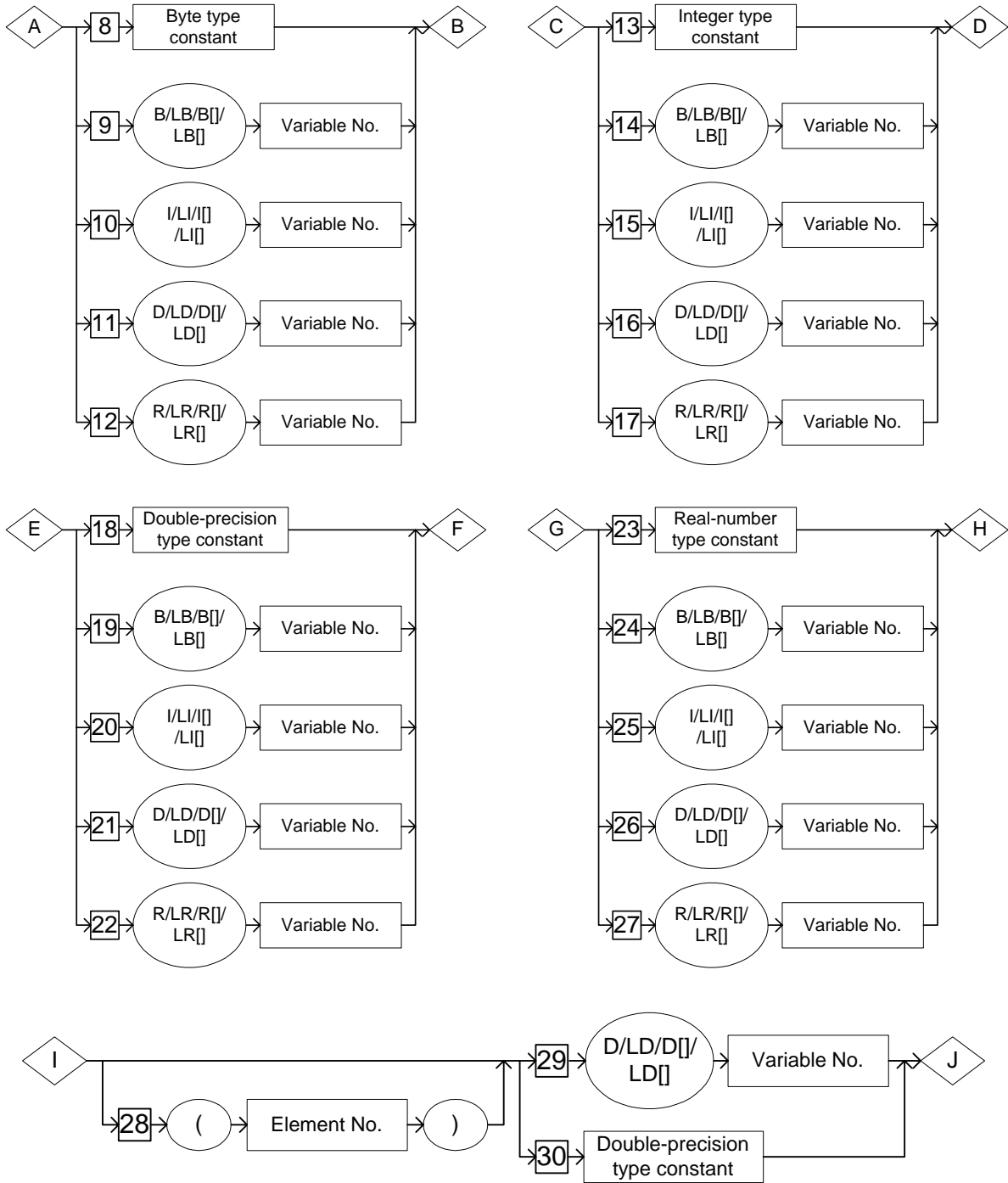

Explanation

1. B Variable number/LB Variable number/B [Array number]/LB [Array number]/I Variable number/LI Variable number/I [Array number]/LI [Array number]/D Variable number/LD Variable number/D [Array number]/LD [Array number]/R Variable number/LR Variable number/R [Array number]/LR [Array number]/P Variable number/LP Variable number/P [Array number]/LP [Array number]/BP Variable number/LBP Variable number/BP [Array number]/LBP [Array number]/EX Variable number/LEX Variable number/EX [Array number]/LEX [Array number]

Choose one of the tags from the following table.

No.	Tag	Explanation	Note
1	B Variable number/ LB Variable number/ B [Array number]/ LB [Array number]	Specifies the number of the byte type variable to be divided.	<Data 1>
2	I Variable number/ LI Variable number/ I [Array number]/ LI [Array number]	Specifies the number of the integer type variable to be divided.	<Data 1>
3	D Variable number/ LD Variable number/ D [Array number]/ LD [Array number]	Specifies the number of the double-precision type variable to be divided.	<Data 1>
4	R Variable number/ LR Variable number/ R [Array number]/ LR [Array number]	Specifies the number of the real-number type variable to be divided.	<Data 1>
5	P Variable number/ LP Variable number/ P [Array number]/ LP [Array number]	Specifies the number of the robot axis position type variable to be divided.	<Data 1>

No.	Tag	Explanation	Note
6	BP Variable number/ LBP Variable number/ BP [Array number]/ LBP [Array number]	Specifies the number of the base axis position type variable to be divided.	<Data 1>
7	EX Variable number/ LEX Variable number/ EX [Array number]/ LEX [Array number]	Specifies the number of the station axis position type variable to be divided.	<Data 1>

2.3 Operating Instruction

2. Byte type constant/B Variable number/LB Variable number/B [Array number]/LB [Array number]/I Variable number/LI Variable number/I [Array number]/LI [Array number]/D Variable number/LD Variable number/D [Array number]/LD [Array number]/R Variable number/LR Variable number/R [Array number]/LR [Array number]

When a B Variable number, LB Variable number, B [Array number], or LB [Array number] is selected from the table in part 1 of this explanation, choose one of the tags from the following table.

No.	Tag	Explanation	Note
8	Byte type constant	Specifies the byte type data by which Data 1 is divided.	<Data 2>
9	B Variable number/ LB Variable number/ B [Array number]/ LB [Array number]	Specifies the number of the byte type variable by which Data 1 is divided.	<Data 2>
10	I Variable number/ LI Variable number/ I [Array number]/ LI [Array number]	Specifies the number of the integer type variable by which Data 1 is divided.	<Data 2>
11	D Variable number/ LD Variable number/ D [Array number]/ LD [Array number]	Specifies the number of the double-precision type variable by which Data 1 is divided.	<Data 2>
12	R Variable number/ LR Variable number/ R [Array number]/ LR [Array number]	Specifies the number of the real-number type variable by which Data 1 is divided.	<Data 2>

3. Integer type constant/B Variable number/LB Variable number/B [Array number]/LB [Array number]/I Variable number/LI Variable number/I [Array number]/LI [Array number]/D Variable number/LD Variable number/D [Array number]/LD [Array number]/R Variable number/LR Variable number/R [Array number]/LR [Array number]

When an I Variable number, LI Variable number, I [Array number], or LI [Array number] is selected from the table in part 1 of this Explanation, choose one of the tags from the following table.

No.	Tag	Explanation	Note
13	Integer type constant	Specifies the integer type data by which Data 1 is divided.	<Data 2>
14	B Variable number/ LB Variable number/ B [Array number]/ LB [Array number]	Specifies the number of the byte type variable by which Data 1 is divided.	<Data 2>
15	I Variable number/ LI Variable number/ I [Array number]/ LI [Array number]	Specifies the number of the integer type variable by which Data 1 is divided.	<Data 2>
16	D Variable number/ LD Variable number/ D [Array number]/ LD [Array number]	Specifies the number of the double-precision type variable by which Data 1 is divided.	<Data 2>
17	R Variable number/ LR Variable number/ R [Array number]/ LR [Array number]	Specifies the number of the real-number type variable by which Data 1 is divided.	<Data 2>

2.3 Operating Instruction

4. Double-precision type constant/B Variable number/LB Variable number/B [Array number]/LB [Array number]/I Variable number/LI Variable number/I [Array number]/LI [Array number]/D Variable number/LD Variable number/D [Array number]/LD [Array number]/R Variable number/LR Variable number/R [Array number]/LR [Array number]

When a D Variable number, LD Variable number, D [Array number], or LD [Array number] is selected from the table in part 1 of this Explanation, choose one of the tags from the following table.

No.	Tag	Explanation	Note
18	Double-precision type constant	Specifies the double-precision type data by which Data 1 is divided.	<Data 2>
19	B Variable number/ LB Variable number/ B [Array number]/ LB [Array number]	Specifies the number of the byte type variable by which Data 1 is divided.	<Data 2>
20	I Variable number/ LI Variable number/ I [Array number]/ LI [Array number]	Specifies the number of the integer type variable by which Data 1 is divided.	<Data 2>
21	D Variable number/ LD Variable number/ D [Array number]/ LD [Array number]	Specifies the number of the double-precision type variable by which Data 1 is divided.	<Data 2>
22	R Variable number/ LR Variable number/ R [Array number]/ LR [Array number]	Specifies the number of the real-number type variable by which Data 1 is divided.	<Data 2>

5. Real-number type constant/B Variable number/LB Variable number/B
 [Array number]/LB [Array number]/I Variable number/LI Variable number/I
 [Array number]/LI [Array number]/D Variable number/LD Variable number/
 D [Array number]/LD [Array number]/R Variable number/LR Variable num-
 ber/R [Array number]/LR [Array number]

When an R Variable number, LR Variable number, R [Array number], or LR [Array number] is selected from the table in part 1 of this Explanation, choose one of the tags from the following table.

No.	Tag	Explanation	Note
23	Real-number type constant	Specifies the real-number type data by which Data 1 is divided.	<Data 2>
24	B Variable number/ LB Variable number/ B [Array number]/ LB [Array number]	Specifies the number of the byte type variable by which Data 1 is divided.	<Data 2>
25	I Variable number/ LI Variable number/ I [Array number]/ LI [Array number]	Specifies the number of the integer type variable by which Data 1 is divided.	<Data 2>
26	D Variable number/ LD Variable number/ D [Array number]/ LD [Array number]	Specifies the number of the double-precision type variable by which Data 1 is divided.	<Data 2>
27	R Variable number/ LR Variable number/ R [Array number]/ LR [Array number]	Specifies the number of the real-number type variable by which Data 1 is divided.	<Data 2>

6. (Element number)

When a P Variable number, LP Variable number, P [Array number], LP [Array number], BP Variable number, LBP Variable number, BP [Array number], LBP [Array number], EX Variable number, LEX Variable number, EX [Array number], or LEX [Array number] is selected from the table in part 1 of this Explanation, the following tag can be added or omitted.

No.	Tag	Explanation	Note
28	(Element number)	Specifies the element of the position type variable by which Data 1 is divided. If omitted, all the elements of the position type variable are specified.	Element number: 1 to 255 Variable B/LB can be used.

7. D Variable number/LD Variable number/D [Array number]/LD [Array number]/Double-precision type constant

When a P Variable number, LP Variable number, P [Array number], LP [Array number], BP Variable number, LBP Variable number, BP [Array number], LBP [Array number], EX Variable number, LEX Variable number, EX [Array number], or LEX [Array number] is selected from the table in part 1 of this Explanation, choose one of the tags from the following table after (Element number) of 6.

No.	Tag	Explanation	Note
29	D Variable number/ LD Variable number/ D [Array number]/ LD [Array number]	Specifies the number of the double-precision variable by which the element of the position type variable is divided.	<Data 2>
30	Double-precision type constant	Specifies the double-precision type data by which the element of the position type variable is divided.	<Data 2>

Example

- (1) DIV B000 10
Divides B000 by 10, and stores the result in B000.
- (2) DIV I000 I001
Divides I000 by I001, and stores the result in I000.
- (3) SET D000 2
DIV P000 (3) D000
Divides the Z axis data by D000 (D000=2), and stores the result in P000.

CNVRT

Instruction set:

SUBSET	STANDARD	EXPANDED
Not available	Available	Available

Function

Converts the pulse type position type variable of Data 2 to the XYZ type position type variable in the specified coordinate system, and stores the result in Data 1.

Construction

CNVRT <Data 1> <Data 2> Coordinate system designation

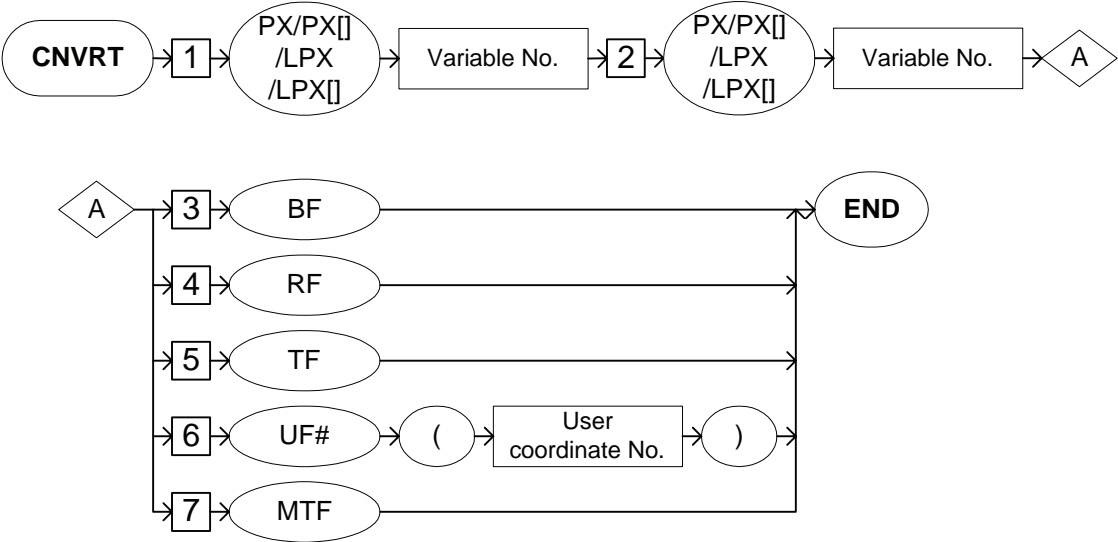

Explanation

1. PX Variable number/LPX Variable number/PX [Array number]/LPX [Array number]

Add the following tag.

No.	Tag	Explanation	Note
1	PX Variable number/ LPX Variable number/ PX [Array number]/ LPX [Array number]	Specifies the number of the expanded position type variable where the converted data is stored.	<Data 1>



Expanded position type variables

The expanded position type variable is a position type variable that depends on the control group in the job.

<Example>

- When the control group is R1:
PX000 indicates P000.
- When the control group is R1 + B1:
PX000 indicates P000 and BP000.
- When the control group is R1 + B1 + ST1:
PX000 indicates P000 + BP000 + EX000.
- When the control group is R1 + R2 + B1 + B2 + ST1 in the coordinated job (master R1 + B1):
PX000 indicates the following:
P000: R2 (slave), P001: R1 (master)
BP000: B2 (slave), BP001: B1 (master)
EX000: ST1

2. PX Variable number/LPX Variable number/PX [Array number]/LPX [Array number]

Add the following tag.

No.	Tag	Explanation	Note
2	PX Variable number/ LPX Variable number/ PX [Array number]/ LPX [Array number]	Specifies the number of the expanded position type variable to be converted.	<Data 2>

3. BF/RF/TF/UF# (User coordinate number)/MTF

Choose one of the tags from the following table.

No.	Tag	Explanation	Note
3	BF	Specifies the conversion in the base coordinate system.	
4	RF	Specifies the conversion in the robot coordinate system.	
5	TF	Specifies the conversion in the tool coordinate system.	
6	UF# (User coordinate number)	Specifies the conversion in the user coordinate system.	No.: 1 to 24 Variable B/I/D/LB/LI/LD can be used.
7	MTF	Specifies the conversion on the master tool coordinate system. On the master tool coordinate system, the data is converted to a position relative to the master manipulator.	Available only with the optional independent coordinate function.

Example

CNVRT PX000 PX001 BF

For the job R1, the pulse type position data of P001 is converted to the XYZ type position data in the base coordinate system and stores the converted data in P000.

AND

Instruction set:

SUBSET	STANDARD	EXPANDED
Not available	Available	Available

Function

Carries out logical multiplication of Data 1 and Data 2, and stores the result in Data 1.

Construction

AND <Data 1> <Data 2>

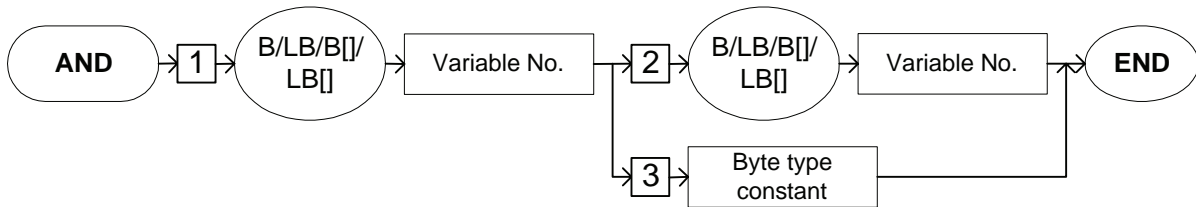

Explanation

1. B Variable number/LB Variable number/B [Array number]/LB [Array number]

Add the following tag.

No.	Tag	Explanation	Note
1	B Variable number/ LB Variable number/ B [Array number]/ LB [Array number]	Specifies the number of the byte type variable for which the logical multiplication is carried out.	<Data 1>

 2. B Variable number/LB Variable number/B [Array number]/LB [Array number]/Byte type constant

Choose one of the tags from the following table.

No.	Tag	Explanation	Note
2	B Variable number/ LB Variable number/ B [Array number]/ LB [Array number]	Specifies the number of the byte type variable for which the logical multiplication is carried out.	<Data 2>
3	Byte type constant	Specifies the byte type data for which the logical multiplication is carried out.	<Data 2>

Example

```
SET B000 5
SET B010 1
AND B000 B010
```

Carries out the logical multiplication of B000 (0000 0101) and B010 (0000 0001), and stores the result (0000 0001=1) in B000.

OR

Instruction set:

SUBSET	STANDARD	EXPANDED
Not available	Available	Available

Function

Carries out the logical sum of Data 1 and Data 2, and stores the result in Data 1.

Construction

OR <Data 1> <Data 2>

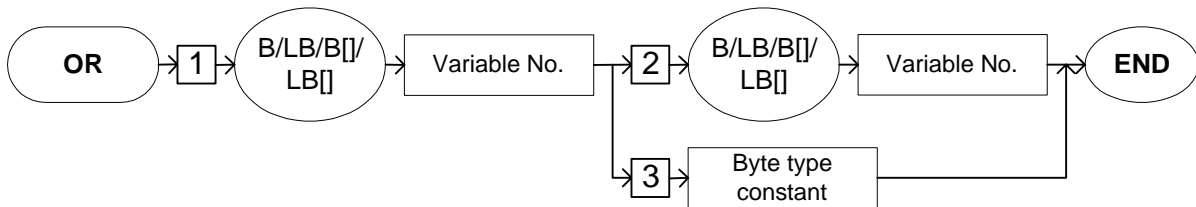

Explanation

1. B Variable number/LB Variable number/B [Array number]/LB [Array number]

Add the following tag.

No.	Tag	Explanation	Note
1	B Variable number/ LB Variable number/ B [Array number]/ LB [Array number]	Specifies the number of the byte type variable for which the logical sum is carried out.	<Data 1>

2. B Variable number/LB Variable number/B [Array number]/LB [Array number]/Byte type constant

Choose one of the tags from the following table.

No	Tag	Explanation	Note
2	B Variable number/ LB Variable number/ B [Array number]/ LB [Array number]	Specifies the number of the byte type variable for which the logical sum is carried out.	<Data 2>
3	Byte type constant	Specifies the byte type data for which the logical sum is carried out.	<Data 2>

Example

```
SET B000 5
SET B010 10
OR B000 B010
```

Carries out the logical sum of B000 (0000 0101) and B010 (0000 1010), and stores the result (0000 1111=15) in B000.

NOT

Instruction set:

SUBSET	STANDARD	EXPANDED
Not available	Available	Available

Function

Carries out the logical negation of Data 2, and stores the result in Data 1.

Construction

NOT <Data 1> <Data 2>

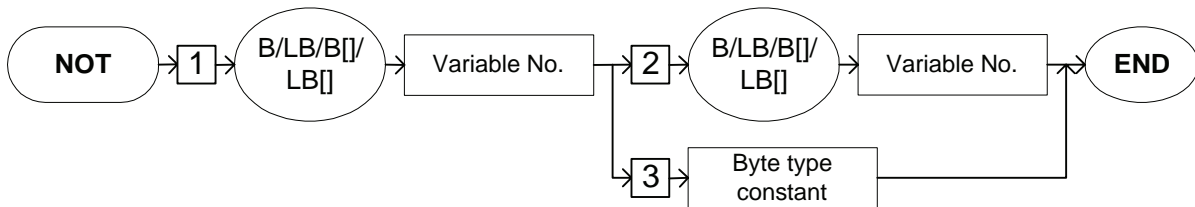

Explanation

1. B Variable number/LB Variable number/B [Array number]/LB [Array number]

Add the following tag.

No.	Tag	Explanation	Note
1	B Variable number/ LB Variable number/ B [Array number]/ LB [Array number]	Specifies the number of the byte type variable to store the result of logical negation.	<Data 1>

2. B Variable number/LB Variable number/B [Array number]/LB [Array number]/Byte type constant

Choose one of the tags from the following table.

No.	Tag	Explanation	Note
2	B Variable number/ LB Variable number/ B [Array number]/ LB [Array number]	Specifies the number of the byte type variable for which the logical negation is carried out.	<Data 2>
3	Byte type constant	Specifies the byte type data for which the logical negation is carried out.	<Data 2>

Example

```
SET B000 0
SET B010 1
NOT B000 B010
```

Carries out the logical negation of B010 (0000 0001), and stores the result (1111 1110=254) in B000.

XOR

Instruction set:

SUBSET	STANDARD	EXPANDED
Not available	Available	Available

Function

Carries out the logical exclusive OR of Data 1 and Data 2, and stores the result in Data 1.

Construction

XOR <Data 1> <Data 2>

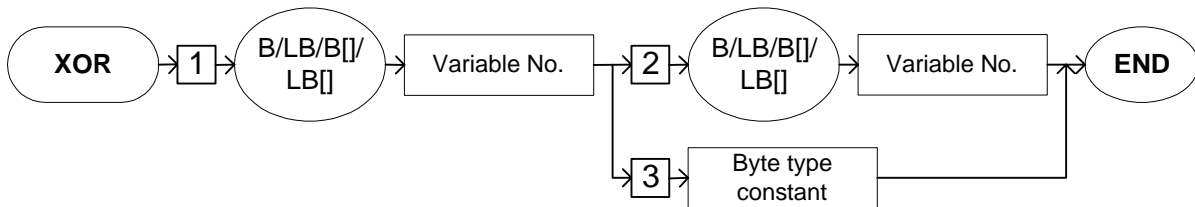

Explanation

1. B Variable number/LB Variable number/B [Array number]/LB [Array number]

Add the following tag.

No.	Tag	Explanation	Note
1	B Variable number/ LB Variable number/ B [Array number]/ LB [Array number]	Specifies the number of the byte type variable for which the exclusive OR is carried out.	<Data 1>

2. B Variable number/LB Variable number/B [Array number]/LB [Array number]/Byte type constant

Choose one of the tags from the following table.

No.	Tag	Explanation	Note
2	B Variable number/ LB Variable number/ B [Array number]/ LB [Array number]	Specifies the number of the byte type variable for which the exclusive OR is carried out.	<Data 2>
3	Byte type constant	Specifies the byte type data for which the exclusive OR is carried out.	<Data 2>

Example

```
SET B000 1
SET B010 5
XOR B000 B010
```

Carries out the exclusive OR of B000 (0000 0001) and B010 (0000 0101), and stores the result (0000 0100=4) in B000.

MFRAME

Instruction set:

SUBSET	STANDARD	EXPANDED
Not available	Available	Available

Function

Creates the user coordinates according to three types of position data; Data 1, Data 2, and Data 3.

Data 1 indicates the position data of the defined point ORG; Data 2 indicates the position data of the defined point XX; and Data 3 indicates the position data of the defined point XY.

Construction

MFRAME User coordinate designation <Data 1> <Data 2> <Data 3>

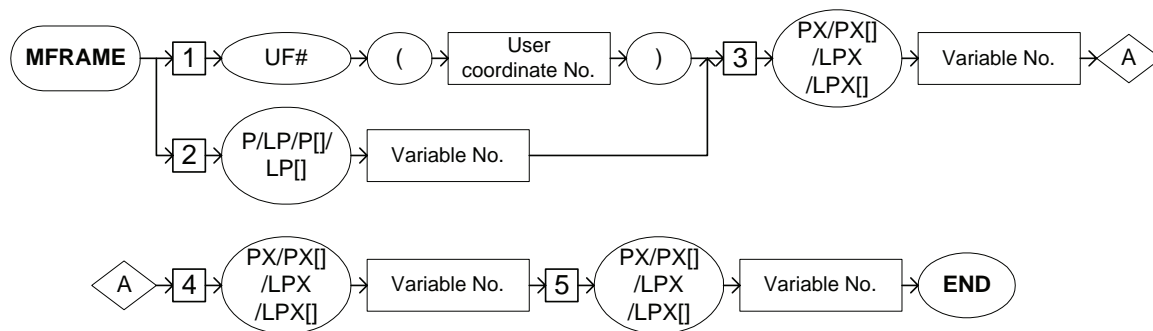

Explanation

1. UF# (User coordinate number)/P Variable number/LP Variable number/P [Array number]/LP [Array number]

Choose one of the tags from the following table.

No.	Tag	Explanation	Note
1	UF# (User coordinate number)	Allocates the number for the user coordinate to be created.	No.: 1 to 24 Variable B/I/D/LB/LI/LD can be used.
2	P Variable number/ LP Variable number/ P [Array number]/ LP [Array number]	Specifies the number of the position type variable where the coordinate values of the user coordinate to be created is stored.	

2. PX Variable number/LPX Variable number/PX [Array number]/LPX [Array number]

Add the following tag.

No.	Tag	Explanation	Note
3	PX Variable number/ LPX Variable number/ PX [Array number]/ LPX [Array number]	Specifies the number of the expanded position type variable where the position data of the user coordinate's defined point ORG has been stored.	<Data 1>

3. PX Variable number/LPX Variable number/PX [Array number]/LPX [Array number]

Add the following tag.

No.	Tag	Explanation	Note
4	PX Variable number/ LPX Variable number/ PX [Array number]/ LPX [Array number]	Specifies the number of the expanded position type variable where the position data of the user coordinate's defined point XX has been stored.	<Data 2>

4. PX Variable number/LPX Variable number/PX [Array number]/LPX [Array number]

Add the following tag.

No	Tag	Explanation	Note
5	PX Variable number/ LPX Variable number/ PX [Array number]/ LPX [Array number]	Specifies the number of the expanded position type variable where the position data of the user coordinate's defined point XY has been stored.	<Data 3>

2.3 Operating Instruction

Example

MFRAME UF#(1) PX000 PX001 PX002

For the job R1, the user coordinate number 1 is created according to three types of position data; P000, P001, and P002 of the user coordinate system.

SETE

Instruction set:

SUBSET	STANDARD	EXPANDED
Not available	Available	Available

Function

Sets Data 2 in the element of position type variable of Data 1.

Construction

SETE <Data 1> (Element number) <Data 2>

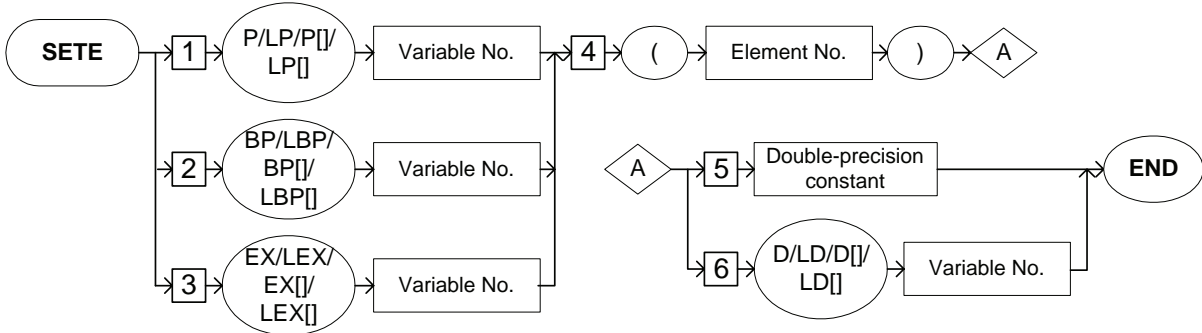

Explanation

1. P Variable number/LP Variable number/P [Array number]/LP [Array number]/BP Variable number/LBP Variable number/BP [Array number]/LBP [Array number]/BP [Array number]/LBP [Array number]/EX Variable number/LEX Variable number/EX [Array number]/LEX [Array number]

Choose one of the tags from the following table.

No.	Tag	Explanation	Note
1	P Variable number/ LP Variable number/ P [Array number]/ LP [Array number]	Specifies the number of the robot axis position type variable where Data 2 is set as an element.	<Data 1>
2	BP Variable number/ LBP Variable number/ BP [Array number]/ LBP [Array number]	Specifies the number of the base axis position type variable where Data 2 is set as an element.	<Data 1>
3	EX Variable number/ LEX Variable number/ EX [Array number]/ LEX [Array number]	Specifies the number of the station axis position type variable where Data 2 is set as an element.	<Data 1>

2. (Element number)

Add the following tag.

No.	Tag	Explanation	Note
4	(Element number)	Specifies the element of the position type variable to be set.	Element No.: 1 to 255 Variable B/LB can be used.

3. Double-precision type constant/D Variable number/LD Variable number/D [Array number]/LD [Array number]

Choose one of the tags from the following table.

No.	Tag	Explanation	Note
5	Double-precision type constant	Specifies the double-precision type data to be set.	<Data 2>
6	D Variable number/ LD Variable number/ D [Array number]/ LD [Array number]	Specifies the number of the double-precision type variable to be set.	<Data 2>

Example

SETE P000 (3) 2000

2000 is set in the Z axis data of P000.

GETE

Instruction set:

SUBSET	STANDARD	EXPANDED
Not available	Available	Available

Function

Stores the element of position type variable of Data 2 in Data 1.

Construction

GETE <Data 1> <Data 2> (Element number)

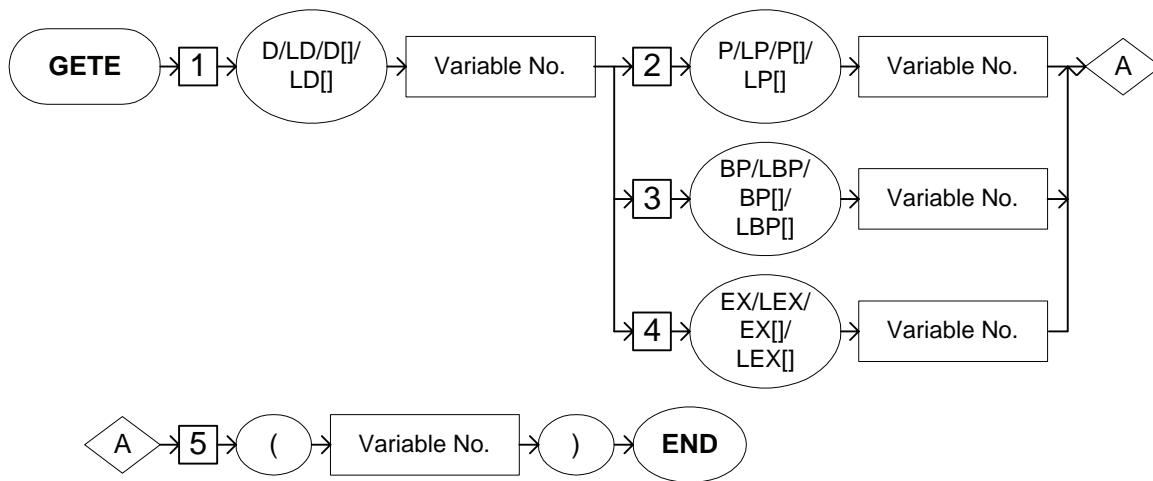

Explanation

1. D Variable number/LD Variable number/D [Array number]/LD [Array number]

Add the following tag.

No.	Tag	Explanation	Note
1	D Variable number/ LD Variable number/ D [Array number]/ LD [Array number]	Specifies the number of the double-precision type variable where the element of position type variable is stored.	<Data 1>

2. P Variable number/LP Variable number/P [Array number]/LP [Array number]/BP Variable number/LBP Variable number/BP [Array number]/LBP [Array number]/EX Variable number/LEX Variable number/EX [Array number]/LEX [Array number]

Choose one of the tags from the following table.

No.	Tag	Explanation	Note
2	P Variable number/ LP Variable number/ P [Array number]/ LP [Array number]	Specifies the number of the robot axis position type variable to be stored.	<Data 2>
3	BP Variable number/ LBP Variable number/ BP [Array number]/ LBP [Array number]	Specifies the number of the base axis position type variable to be stored.	<Data 2>
4	EX Variable number/ LEX Variable number/ EX [Array number]/ LEX [Array number]	Specifies the number of the station axis position type variable to be stored.	<Data 2>

3. (Element number)

Add the following tag.

No.	Tag	Explanation	Note
5	(Element number)	Specified the number of the of the position type variable element to be stored.	Element No.: 1 to 255 Variable B/LB can be used.

Example

GETE D000 P000 (3)

The Z axis data of P000 is stored in D000.

GETS

Instruction set:

SUBSET	STANDARD	EXPANDED
Not available	Available	Available

Function

Stores the system variable of Data 2 in Data 1.

Construction

GETS <Data 1> <Data 2>

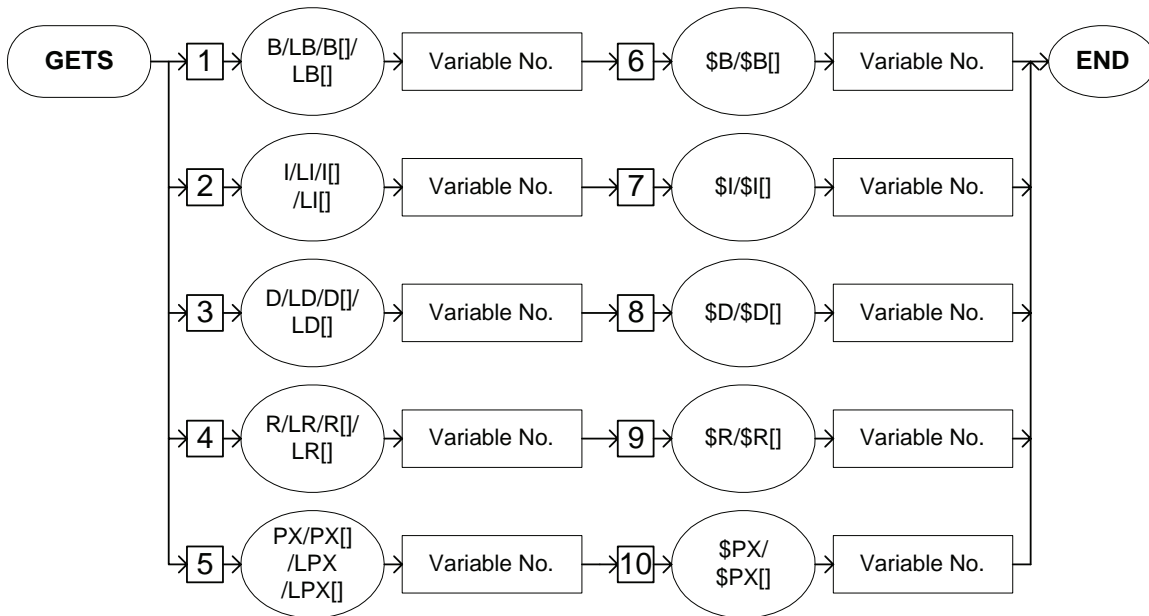

Explanation

1. B Variable number/LB Variable number/B [Array number]/LB [Array number]/I Variable number/LI Variable number/I [Array number]/LI [Array number]/D Variable number/LD Variable number/D [Array number]/LD [Array number]/R Variable number/LR Variable number/R [Array number]/LR [Array number]/PX Variable number/LPX Variable number/PX [Array number]/LPX [Array number]

Choose one of the tags from the following table.

No.	Tag	Explanation	Note
1	B Variable number/ LB Variable number/ B [Array number]/ LB [Array number]	Specifies the number of the byte type variable to store the system variable.	<Data 1>
2	I Variable number/ LI Variable number/ I [Array number]/ LI [Array number]	Specifies the number of the integer type variable to store the system variable.	<Data 1>
3	D Variable number/ LD Variable number/ D [Array number]/ LD [Array number]	Specifies the number of the double-precision type variable to store the system variable.	<Data 1>
4	R Variable number/ LR Variable number/ R [Array number]/ LR [Array number]	Specifies the number of the real-number type variable to store the system variable.	<Data1>
5	PX Variable number/ LPX Variable number/ PX [Array number]/ LPX [Array number]	Specifies the number of the expanded position type variable to store the system variable.	<Data 1>



System variable

The system variables are written by the controller system and can be referred only by a GETS instruction. The following system variables are available.

System Variable	Type	No.	Explanation
\$B type variable	Byte type	\$B002	Detected /Not detected by the optional SRCH instruction 0: Not detected, 1: Detected
		\$B003	The number of RIN#(1)s detected by the optional NSRCH instruction
		\$B004	The number of RIN#(2)s detected by the optional NSRCH instruction
		\$B005	The number of RIN#(3)s detected by the optional NSRCH instruction
		\$B006	The number of RIN#(4)s detected by the optional NSRCH instruction
		\$B007	The number of RIN#(5)s detected by the optional NSRCH instruction
		\$B008	Result of the optional SYSTART instruction 1: Normal termination, 0: Abnormal termination
		\$B009	Result of the SETFILE/GETFILE instruction 0: Normal termination, Other than 0: Abnormal termination
		\$B014	Result of the optional HSEN instruction 1: Setting status completed, 0: Others

Continued



Continued

System Variable	Type	No.	Explanation
\$PX type variable	Expanded position type	\$PX000	Current value (pulse type)
		\$PX001	Current value (XYZ type)
		\$PX002	Position detected by the optional SRCH instruction (pulse type)
		\$PX003	Position detected by the optional STCH instruction (XYZ type)
		\$PX004	Current value excluding the shift amount (XYZ type)
		\$PX005	Teaching position (pulse type)
		\$PX006	Operation target position (pulse type)
		\$PX040	Path correction amount (available only with the optional COMARC function)
		\$PX100 to \$PX149	RIN#(1)'s detected position by the optional NSRCH instruction (pulse type)
		\$PX150 to \$PX199	RIN#(1)'s detected position by the optional NSRCH instruction (XYZ type)
		\$PX200 to \$PX249	RIN#(2)'s detected position by the optional NSRCH instruction (pulse type)
		\$PX250 to \$PX299	RIN#(2)'s detected position by the optional NSRCH instruction (XYZ type)
		\$PX300 to \$PX349	RIN#(3)'s detected position by the optional NSRCH instruction (pulse type)
		\$PX350 to \$PX399	RIN#(3)'s detected position by the optional NSRCH instruction (XYZ type)
\$PX400 to \$PX449	RIN#(4)'s detected position by the optional NSRCH instruction (pulse type)		

Continued

 Continued

System Variable	Type	No.	Explanation
\$PX type variable	Expanded position type	\$PX450 to \$PX499	RIN#(4)'s detected position by the optional NSRCH instruction (XYZ type)
		\$PX500 to \$PX549	RIN#(5)'s detected position by the optional NSRCH instruction (pulse type)
		\$PX550 to \$PX599	RIN#(5)'s detected position by the optional NSRCH instruction (XYZ type)

2. \$B Variable number/\$B [Array number]

When a B Variable number, LB Variable number, B [Array number], or LB [Array number] is selected from the table in part 1 of this Explanation, add the following tag.

No.	Tag	Explanation	Note
6	\$B Variable number/ \$B [Array number]	Specifies the number of the byte type system variable to be stored.	<Data 2>

3. \$I Variable number/\$I [Array number]

When an I Variable number, LI Variable number, I [Array number], or LI [Array number] is selected from the table in part 1 of this Explanation, add the following tag.

No.	Tag	Explanation	Note
7	\$I Variable number/ \$I [Array number]	Specifies the number of the integer type system variable to be stored.	<Data 2>

4. \$D Variable number/\$D [Array number]

When a D Variable number, LD Variable number, D [Array number], or LD [Array number] is selected from the table in part 1 of this Explanation, add the following tag.

No.	Tag	Explanation	Note
8	\$D Variable number/ \$D [Array number]	Specifies the number of the double-precision type system variable to be stored.	<Data 2>

5. \$R Variable number/\$R [Array number]

When an R Variable number, LR Variable number, R [Array number], or LR [Array number] is selected from the table in part 1 of this Explanation, add the following tag.

No.	Tag	Explanation	Note
9	\$R Variable number/ \$R [Array number]	Specifies the number of the real-number type system variable to be stored.	<Data 2>

6. \$PX Variable number/\$PX [Array number]

When a PX Variable number, LPX Variable number, PX [Array number], or LPX [Array number] is selected from the table in part 1 of this Explanation, add the following tag.

No.	Tag	Explanation	Note
10	\$PX Variable number/ \$PX [Array number]	Specifies the number of the expanded position type system variable to be stored.	<Data 2>

Example

(1) GETS B000 \$B002

The result of the SRCH instruction is stored in B000.

(2) GETS PX000 \$PX000

For the job R1, the pulse type current value is stored in P000.

SQRT

Instruction set:

SUBSET	STANDARD	EXPANDED
Not available	Available	Available

Function

Calculates the square root of Data 2, and stores the result in Data 1.

Construction

SQRT <Data 1> <Data 2>

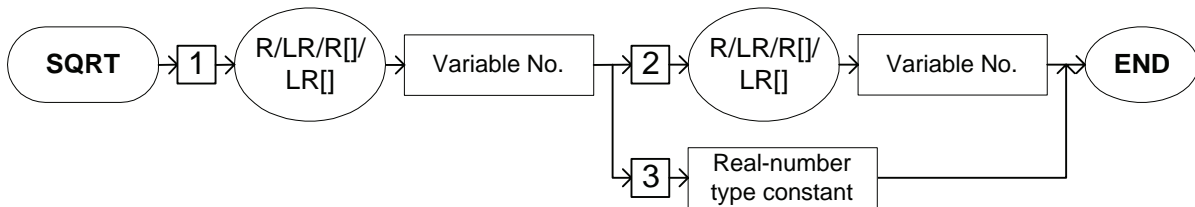

Explanation

1. R Variable number/LR Variable number/R [Array number]/LR [Array number]

Add the following tag.

No.	Tag	Explanation	Note
1	R Variable number/ LR Variable number/ R [Array number]/ LR [Array number]	Specifies the number of the real-number type variable to store the result.	<Data 1>

2. R Variable number/LR Variable number/R [Array number]/LR [Array number]/Real-number type constant

Choose one of the tags from the following table.

No.	Tag	Explanation	Note
2	R Variable number/ LR Variable number/ R [Array number]/ LR [Array number]	Specifies the number of the real-number type variable whose square root is calculated.	<Data 2>
3	Real-number type constant	Specifies the real-number type data whose square root is calculated.	<Data 2>

Example

SQRT R000 2

1.414214E + 00 is stored in R000.

SIN

Instruction set:

SUBSET	STANDARD	EXPANDED
Not available	Available	Available

Function

Calculates the sine of Data 2, and stores the result in Data 1.

Construction

SIN <Data 1> <Data 2>

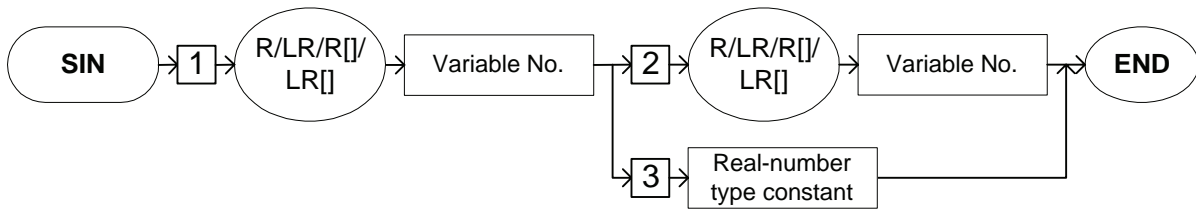

Explanation

1. R Variable number/LR Variable number/R [Array number]/LR [Array number]

Add the following tag.

No.	Tag	Explanation	Note
1	R Variable number/ LR Variable number/ R [Array number]/ LR [Array number]	Specifies the number of the real-number type variable to store the result.	<Data 1>

2. R Variable number/LR Variable number/R [Array number]/LR [Array number]/Real-number type constant

Choose one of the tags from the following table.

No.	Tag	Explanation	Note
2	R Variable number/ LR Variable number/ R [Array number]/ LR [Array number]	Specifies the number of the real-number type variable whose sine is calculated.	<Data 2>
3	Real-number type constant	Specifies the real-number type data whose sine is calculated.	<Data 2>

Example

SIN R000 60

8.660254E - 01 is stored in R000.

COS

Instruction set:

SUBSET	STANDARD	EXPANDED
Not available	Available	Available

Function

Calculates the cosine of Data 2, and stores the result in Data 1.

Construction

COS <Data 1> <Data 2>

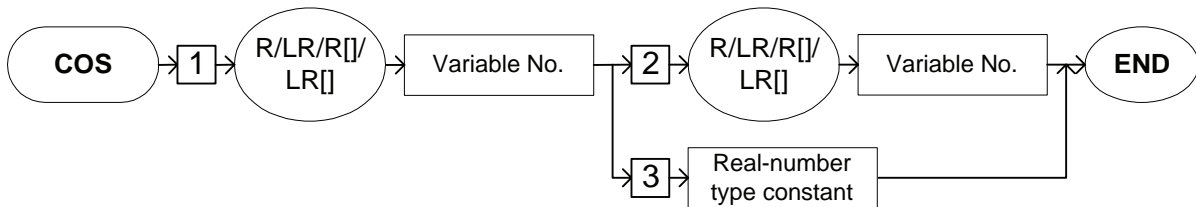

Explanation

1. R Variable number/LR Variable number/R [Array number]/LR [Array number]

Add the following tag.

No.	Tag	Explanation	Note
1	R Variable number/ LR Variable number/ R [Array number]/ LR [Array number]	Specifies the number of the real-number type variable to store the result.	<Data 1>

2. R Variable number/LR Variable number/R [Array number]/LR [Array number]/Real-number type constant

Choose one of the tags from the following table.

No.	Tag	Explanation	Note
2	R Variable number/ LR Variable number/ R [Array number]/ LR [Array number]	Specifies the number of the real-number type variable whose cosine is calculated.	<Data 2>
3	Real-number type constant	Specifies the real-number type data whose cosine is calculated.	<Data 2>

Example

COS R000 60

5.000000E - 01 is stored in R000.

ATAN

Instruction set:

SUBSET	STANDARD	EXPANDED
Not available	Available	Available

Function

Calculates the arc tangent of Data 2, and stores the result in Data 1.

Construction

ATAN <Data 1> <Data 2>

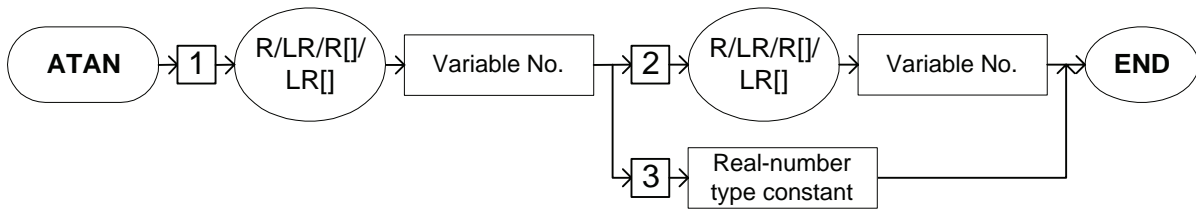

Explanation

1. R Variable number/LR Variable number/R [Array number]/LR [Array number]

Add the following tag.

No.	Tag	Explanation	Note
1	R Variable number/ LR Variable number/ R [Array number]/ LR [Array number]	Specifies the number of the real-number type variable to store the result.	<Data 1>

2. R Variable number/LR Variable number/R [Array number]/LR [Array number]/Real-number type constant

Choose one of the tags from the following table.

No.	Tag	Explanation	Note
2	R Variable number/ LR Variable number/ R [Array number]/ LR [Array number]	Specifies the number of the real-number type variable whose arc tangent is calculated.	<Data 2>
3	Real-number type constant	Specifies the real-number type data whose arc tangent is calculated.	<Data 2>

Example

ATAN R000 60

8.904516E + 01 is stored in R000.

MULMAT

Instruction set:

SUBSET	STANDARD	EXPANDED
Not available	Available	Available

Function

Calculates the matrix multiplication of Data 2 and Data 3, and stores the result in Data 1.

Construction

MULMAT <Data 1> <Data 2> <Data 3>

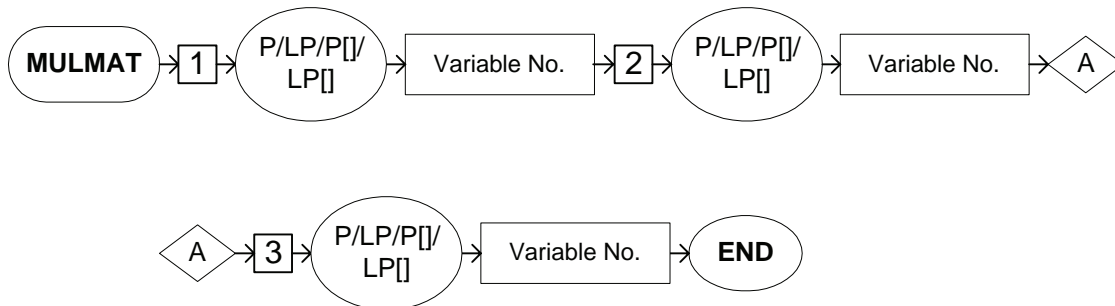

Explanation

1. P Variable number/LP Variable number/P [Array number]/LP [Array number]

Add the following tag.

No.	Tag	Explanation	Note
1	P Variable number/ LP Variable number/ P [Array number]/ LP [Array number]	Specifies the number of the position type variable to store the result.	<Data 1>

2. P Variable number/LP Variable number/P [Array number]/LP [Array number]

Add the following tag.

No.	Tag	Explanation	Note
2	P Variable number/ LP Variable number/ P [Array number]/ LP [Array number]	Specifies the number of the position type variable for which the matrix multiplication is calculated.	<Data 2>

3. P Variable number/LP Variable number/P [Array number]/LP [Array number]

Add the following tag.

No.	Tag	Explanation	Note
3	P Variable number/ LP Variable number/ P [Array number]/ LP [Array number]	Specified the number of the position type variable for which the matrix multiplication is calculated.	<Data 3>



MULMAT and INVMAT instructions

The amount of shift for a three-dimensional shift can be obtained by using the MULMAT and INVMAT instructions.

The instructions, exclusive to the NX100, to obtain the shift amount are used for the optional three-dimensional shift function. However, the amount of the three-dimensional shift can be also obtained by using the standard instructions, MULMAT and INVMAT.

The target value for a three-dimensional shift can be calculated by the following equation.

$$P_{\text{new}} = P_{3d} \times P_{\text{old}}$$

Where P_{new} : Target position after a three-dimensional shift

P_{3d} : Three-dimensional shift amount

P_{old} : Taught position

The amount of a three-dimensional shift can be obtained as follows:

$$P_{3d} = P_{\text{new}} \times P_{\text{old}}^{-1}$$

Example

MOVL P010 V=500

GETS PX020 \$PX001: Stores the current XYZ type value in P020.

INVMAT P021 P010: Calculates the inverse matrix of the taught position.

MULMAT P023 P020 P021: The amount of the three-dimensional shift (P023) is obtained.

INVMAT

Instruction set:

SUBSET	STANDARD	EXPANDED
Not available	Available	Available

Function

Calculates the inverse matrix of Data 2, and stores the result in Data 1.

Construction

INVMAT <Data 1> <Data 2>

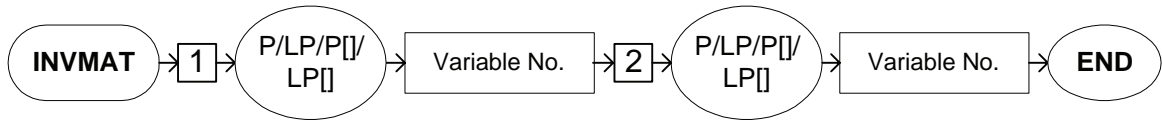

Explanation

1. P Variable number/LP Variable number/P [Array number]/LP [Array number]

Add the following tag.

No.	Tag	Explanation	Note
1	P Variable number/ LP Variable number/ P [Array number]/ LP [Array number]	Specifies the number of the position type variable to store the result.	<Data 1>

2. P Variable number/LP Variable number/P [Array number]/LP [Array number]

Add the following tag.

No.	Tag	Explanation	Note
2	P Variable number/ LP Variable number/ P [Array number]/ LP [Array number]	Specifies the number of the position type variable for which the inverse matrix is calculated.	<Data 2>

Example

MOVL P010 V=500

GETS PX020 \$PX001: Stores the current XYZ type value in P020.

INVMAT P021 P010: Calculates the inverse matrix of the taught position.

MULMAT P023 P020 P021: The amount of the three-dimensional shift (P023) is obtained.

SETFILE

Instruction set:

SUBSET	STANDARD	EXPANDED
Not available	Available	Available

Function

Changes the specified data of the specified condition file to the numeric data of Data 1. Specify the data of the condition file to be changed by its element number.

Construction

SETFILE Condition file specification (Element number) <Data 1>

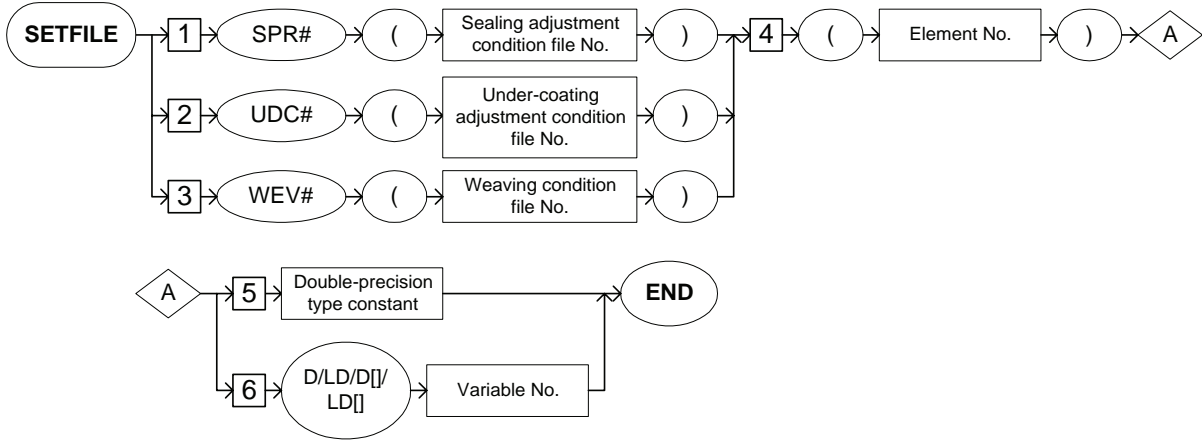

2.3 Operating Instruction

Explanation

1. SPR# (Sealing adjustment condition file number)/UDC# (Under-coating adjustment condition file number)/WEV# (Weaving condition file number)

Choose one of the tags from the following table.

No.	Tag	Explanation	Note
1	SPR# (Sealing adjustment condition file number)	Specifies the number of the sealing (spray) adjustment condition file.	No.: 1 Variable B/I/D/LB/LI/LD can be used. Available only with the optional servo sealing gun function.
2	UDC# (Under-coating adjustment condition file number)	Specifies the number of the number of the under-coating adjustment condition file.	No.: 1 Variable B/I/D/LB/LI/LD can be used. Available only with the optional under-coating function.
3	WEV# (Weaving condition file number)	Specifies the number of the weaving condition file.	No.: 1 to 16 Variable B/I/D/LB/LI/LD can be used.

2. (Element number)

Add the following tag.

No.	Tag	Explanation	Note
4	(Element number)	Specifies the element number of the condition file data to be changed.	Element No.: 1 to 255 Variable B/LB can be used.

3. Double-precision type constant/D Variable number/LD Variable number/D [Array number]/LD [Array number]

Choose one of the tags from the following table.

No.	Tag	Explanation	Note
5	Double-precision type constant	Specifies the double-precision type data to be changed.	<Data 1>
6	D Variable number/ LD Variable number/ D [Array number]/ LD [Array number]	Specifies the number of the double-precision type variable of the data to be changed.	<Data 1>



Element number of each condition file

The element number of each item in the condition file is shown below.

<Weaving condition file>

Element No.	Item	Units	Remarks
1	MODE		
2	SMOOTHING		
3	SPEED		
4	FREQUENCY	0.1 Hz	
5	AMPLITUDE (ACTIVE IN SINGLE)	0.001 mm	
6	PATTERN VERTICAL	0.001 mm	
7	PATTERN HORIZONTAL	0.001 mm	
8	PATTERN ANGLE	0.01 deg.	
9	ANGLE	0.01 deg.	
10	TIMER MODE (SECT 1 to 4)		Stop positions 1 to 4 (SECT 1 to 4) designated by bit data
11 to14	MOVING TIME	0.1 sec.	Sections 1 to 4
15 to18	TIMER (timer count)	0.1 sec.	Duration of a pause between two sections.
19	HOVER WEAVING SET		Optional
20	HOVER WEAVING TIME	0.01 sec.	Optional
21	HOVER WEAVING INPUT SIGNAL		Optional

For details of the weaving condition file, refer to "Chapter 11.10 Weaving Condition File" in NX100 OPERATOR'S MANUAL FOR ARC WELDING (RE-CSO-A031).

Example

```
SETFILE WEV#(1) (5) 3500
```

Changes the amplitude setting in the weaving condition file number 1 to 3.500 mm.

GETFILE

Instruction set:

SUBSET	STANDARD	EXPANDED
Not available	Available	Available

Function

Stores the data of the specified condition file in Data 1.
Specify the data of the condition file to be stored by its element number.

Construction

GETFILE <Data 1> Condition file designation (Element number)

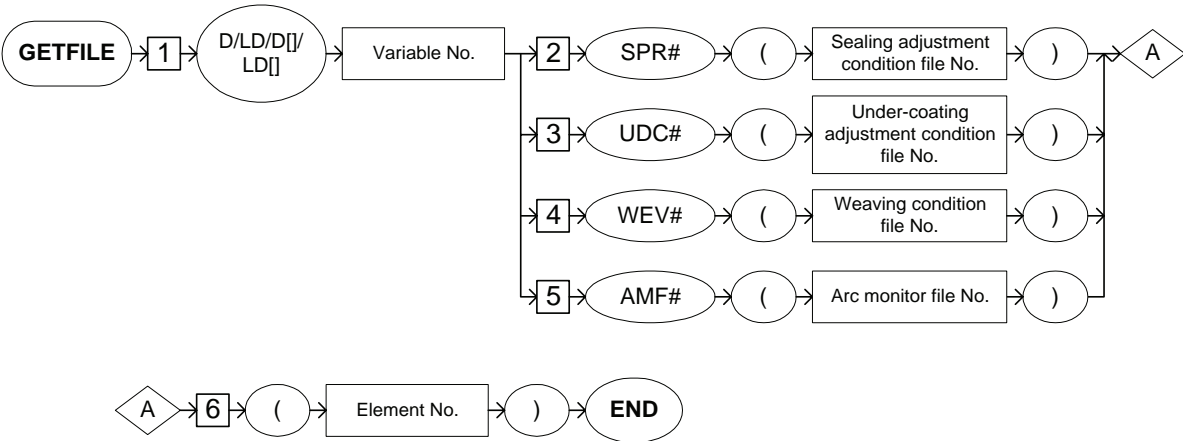

Explanation

1. D Variable number/LD Variable number/D [Array number]/LD [Array number]

Add the following tag.

No.	Tag	Explanation	Note
1	D Variable number/ LD Variable number/ D [Array number]/ LD [Array number]	Specifies the number of the double-precision type variable to store the data.	<Data 1>

2.3 Operating Instruction

2. SPR# (Sealing adjustment condition file number)/UDC# (Under-coating adjustment condition file number)/WEV# (Weaving condition file number)/AMF# (Arc monitor file number)

Choose one of the tags from the following table.

No.	Tag	Explanation	Note
2	SPR# (Sealing adjustment condition file number)	Specifies the number of the sealing (spray) adjustment condition file.	No.: 1 Variable B/I/D/LB/LI/LD can be used. Available only with the optional servo sealing gun function.
3	UDC# (Under-coating adjustment condition file number)	Specifies the number of the under-coating adjustment condition file.	No.: 1 Variable B/I/D/LB/LI/LD can be used. Available only with the optional under-coating function.
4	WEV# (Weaving condition file number)	Specifies the number of the weaving condition file.	No.: 1 to 16 Variable B/I/D/LB/LI/LD can be used.
5	AMF# (Arc monitor file number)	Specifies the number of the arc monitor file.	No.: 1 to 50 Variable B/I/D/LB/LI/LD can be used. Available only with the optional arc monitor function.

3. (Element number)

Add the following tag.

No.	Tag	Explanation	Note
6	(Element number)	Specifies the element number of the condition file data to be stored.	Element No.: 1 to 255 Variable B/LB can be used.

Example

GETFILE D000 WEV#(1) (6)

Stores the vertical distance (PATTERN VERTICAL) in the weaving condition file number 1 in D000.

SETREG

Instruction set:

SUBSET	STANDARD	EXPANDED
Not available	Available	Available

Function

Copies the specified integer type variable data into the register.

Construction

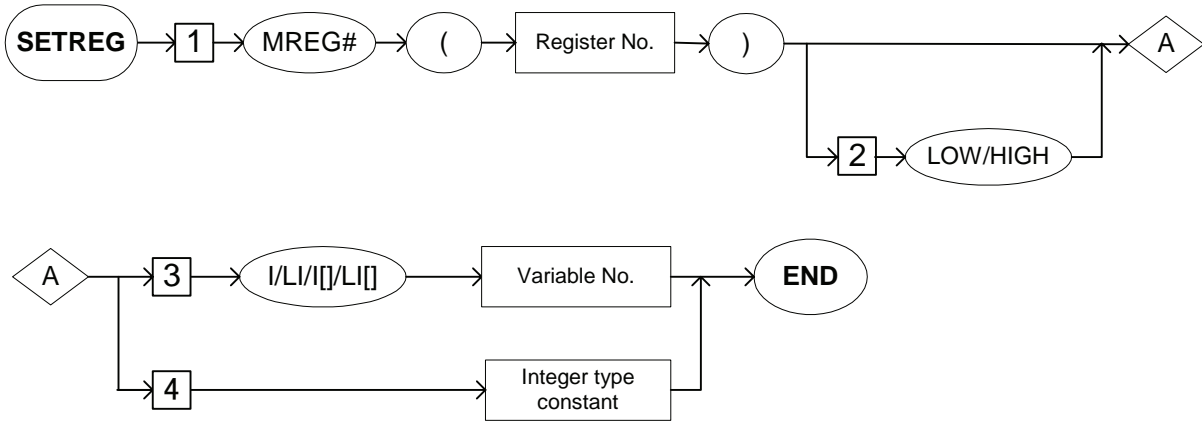

Explanation

1. MREG# (Register number)

No.	Tag	Explanation	Note
1	MREG# (Register number)	Specifies the register number to save the data.	No.: 0 to 499 Variable B/I/D/LB/LI/LD can be used.

2. LOW/HIGH

No.	Tag	Explanation	Note
2	LOW/HIGH	Specifies when copying the data into the lower/higher 8 bits of the register.	

2.3 Operating Instruction

3. I Variable number/LI Variable number/I [Array number]/LI [Array number]

No.	Tag	Explanation	Note
3	I Variable number/ LI Variable number/ I [Array number]/ LI [Array number]	Specifies the data number to be saved in the register.	
4	Integer type variable	Input the data to be saved in the register.	

GETREG

Instruction set:

SUBSET	STANDARD	EXPANDED
Not available	Available	Available

Function

Copies the specified register data into the integer type variable.

Construction

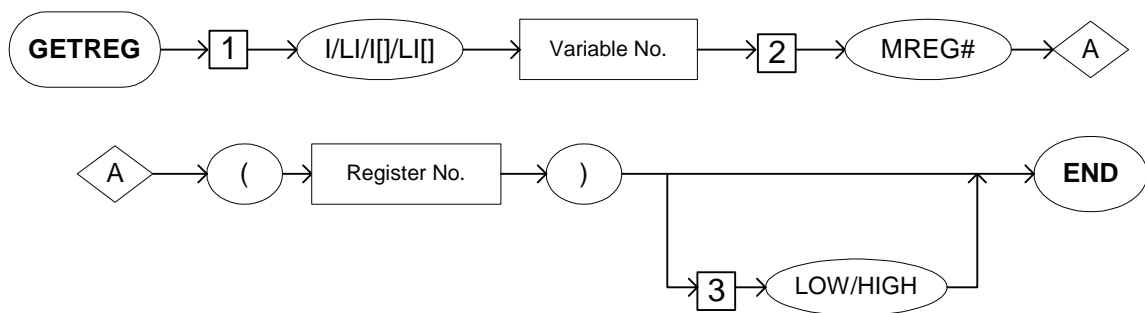

Explanation

1. I Variable number/LI Variable number/I [Array number]/LI [Array number]

No.	Tag	Explanation	Note
1	I Variable number/ LI Variable number/ I [Array number]/ LI [Array number]	Specifies the number of the integer type variable to save the register data.	

2. MREG# (Register number)

No.	Tag	Explanation	Note
2	MREG# (Register number)	Specifies the desired register number to be saved into the integer type variable.	No.: 0 to 499 Variable B/I/D/LB/LI/LD can be used.

2.3 Operating Instruction

3. LOW/HIGH

No.	Tag	Explanation	Note
3	LOW/HIGH	Specifies when saving the lower/higher 8 bits out of 16 bits register.	

2.4 Move Instruction

MOVJ

Instruction set:

SUBSET	STANDARD	EXPANDED
Available	Available	Available

Function

Moves to the teaching position by joint interpolation.

Construction

The tag which can be used is limited by the type of the job.

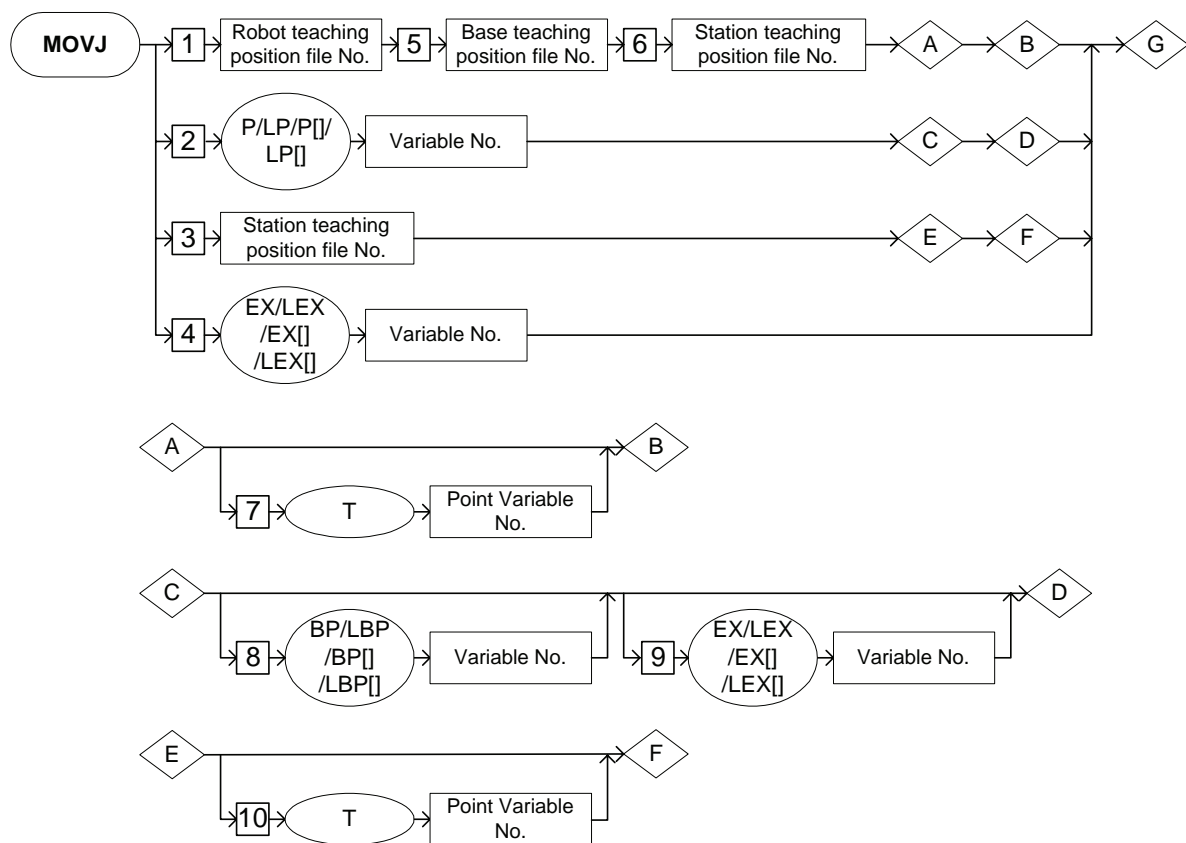

2.4 Move Instruction

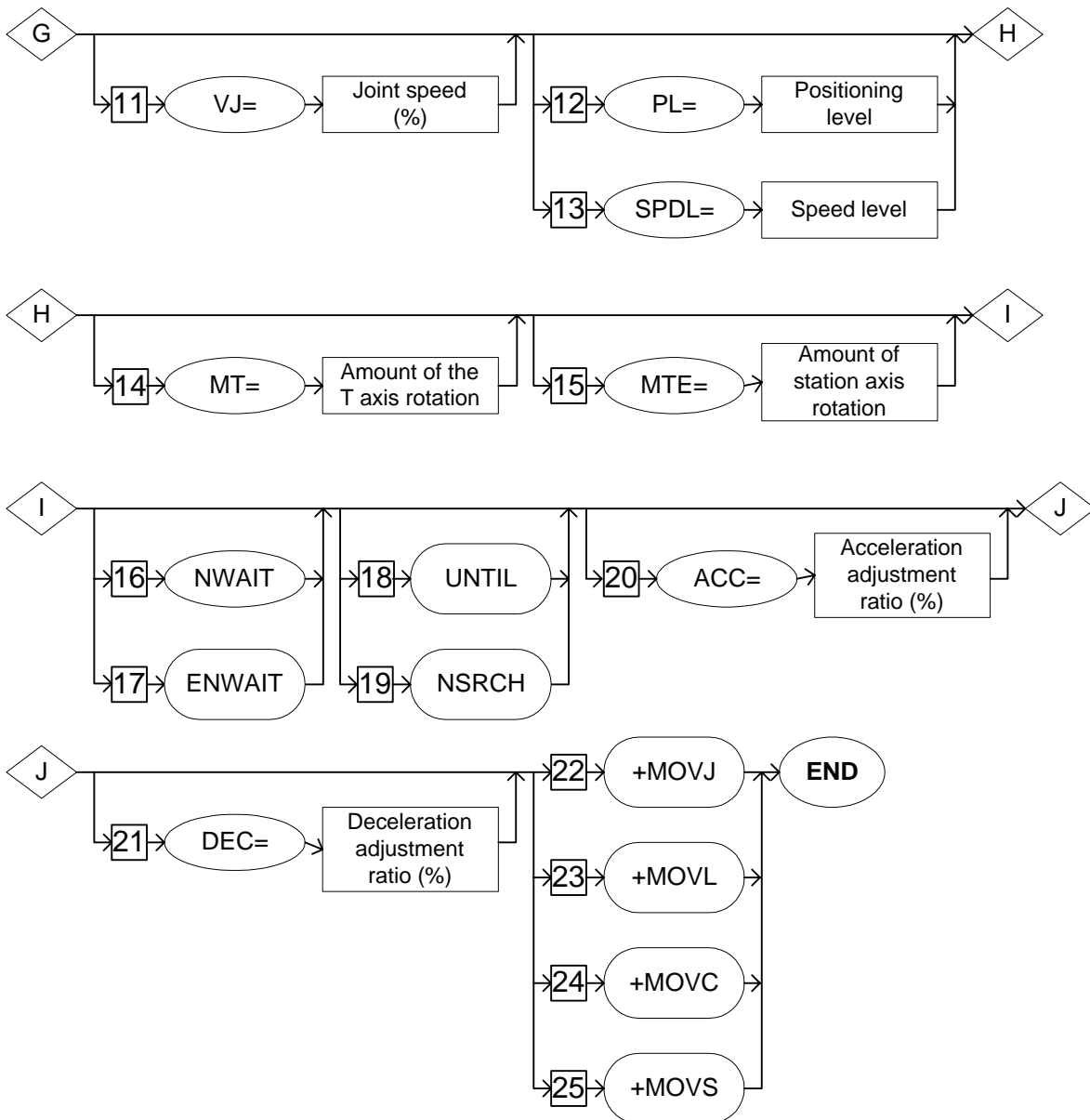

Job Type and Control Group

No.	Job Type	Control Group	Remarks
1	Single	One manipulator (standard)	
2	Single	One manipulator with base axis	
3	Single	One manipulator with station axis	
4	Single	One manipulator with base and station axes	
5	Single	Station axis only	
6	Coordinated	Two manipulators	Optional
7	Coordinated	Two manipulators with base axis	Optional

Availability of Each Tag

No	Tag	Control Group							Note
		1	2	3	4	5	6	7	
1	Robot teaching position file number	●	●	●	●	×	●	●	
2	P/LP/P[]/LP[]	●	●	●	●	×	●	●	
3	Station teaching position file number	×	×	×	×	●	×	×	
4	EX/LEX/EX[]/LEX[]	×	×	×	×	●	×	×	
5	Base axis teaching position file number	×	●	×	●	×	×	●	
6	Station teaching position file number	×	×	●	●	×	×	×	
7	T	○	○	○	○	×	○	○	Optional
8	BP/LBP/BP[]/LBP[]	×	●	×	●	×	×	●	
9	EX/LEX/EX[]/LEX[]	×	×	●	●	×	×	×	
10	T	×	×	×	×	○	×	×	Optional
11	VJ=	●	●	●	●	●	●	●	
12	PL=	●	●	●	●	●	●	●	
13	SPDL=	○	○	○	○	×	○	○	Optional
14	MT=	○	○	○	○	×	×	×	Optional
15	MTE=	×	×	○	○	○	×	×	Optional
16	NWAIT	●	●	●	●	●	●	●	
17	ENWAIT	○	○	○	○	○	○	○	Optional
18	UNTIL	●	●	●	●	●	●	●	
19	NSRCH	○	○	○	○	○	○	○	Optional
20	ACC=	●	●	●	●	●	●	●	
21	DEC=	●	●	●	●	●	●	●	
22	+MOVJ	×	×	×	×	×	○	○	Optional
23	+MOVL	×	×	×	×	×	○	○	Optional
24	+MOVCL	×	×	×	×	×	○	○	Optional
25	+MOVSL	×	×	×	×	×	○	○	Optional

●: Available

○: Available only with optional function enabled

×: Not available

Explanation

1. Robot teaching position file number /P Variable number /LP Variable number /P [Array number] /LP [Array number] /Station teaching position file number /EX Variable number /LEX Variable number /EX [Array number] /LEX [Array number]

Choose one of the tags from the following table.

No	Tag	Explanation	Note
1	Robot teaching position file number	The robot axis teaching position in each step is written in this file unconditionally when the step is taught. This teaching position cannot be edited.	On the job display, this tag is not displayed.
2	P Variable number/ LP Variable number/ P [Array number]/ LP [Array number]	Specifies the position variable number of the robot axis. Moves to the position data set in the variable of the specified number.	Variable number: 000 to 127
3	Station teaching position file number	The station axis teaching position in each step is written in this file unconditionally when the step is taught. This teaching position cannot be edited.	On the job display, this tag is not displayed.
4	EX Variable number/ LEX Variable number/ EX [Array number]/ LEX [Array number]	Specifies the position variable number of the station axis. Moves to the position data set in the variable of the specified number.	Variable number: 000 to 127



Position Variables

There are the following three kinds of position variables.

- Robot axis : P000-P127
- Base axis : BP000-BP127
- Station axis : EX000-EX127

A position variable can store the position data as pulse type or XYZ type.



Local Variables and Arrangement Variables

Local variables and arrangement variables are available only for the expanded instruction set.

P000 and P[0] show the same one.

2. Base Teaching Position File Number

When a robot teaching position file number is selected from the table in part 1 of this Explanation, add the following tag.

No	Tag	Explanation	Note
5	Base teaching position file number	The base axis teaching position in each step is written in this file unconditionally when the step is taught. This teaching position cannot be edited.	On the job display, this tag is not displayed.

3. Station Teaching Position File Number

When a robot teaching position file number is selected from the table in part 1 of this Explanation, add the following tag.

No	Tag	Explanation	Note
6	Station teaching position file number	The station axis teaching position in each step is written in this file unconditionally when the step is taught. This teaching position cannot be edited.	On the job display, this tag is not displayed.

4. T Point Variable number

When a robot teaching position file number is selected from the table in part 1 of this Explanation, the following tag can be added or omitted.

No	Tag	Explanation	Note
7	T Point Variable number	Specifies the number of the point variable. The point variable manages the teaching positions registered in the job, and is used to move the manipulator to the same position several times in one job.	Available only with the optional point variable function.

5. BP Variable number /LBP Variable number /BP [Array number] /LBP [Array number]

When a P Variable number, LP Variable number, P [Array number], or LBP [Array number] is selected from the table in part 1 of this Explanation, the following tag can be added.

No	Tag	Explanation	Note
8	BP Variable number/ LBP Variable number/ BP [Array number] / LBP [Array number]	Specifies the position variable number of the base axis. Moves to the position data set in the variable of the specified number.	Variable number: 000 to 127

2.4 Move Instruction

6. EX Variable number /LEX Variable number /EX [Array number] /LEX [Array number]

When a P Variable number, LP Variable number, P [Array number], or LP [Array number] is selected from the table in part 1 of this Explanation, the following tag can be added.

No	Tag	Explanation	Note
9	EX Variable number/ LEX Variable number/ EX [Array number]/ LEX [Array number]	Specifies the position variable number of the station axis. Moves to the position data set in the variable of the specified number.	Variable number: 000 to 127

7. T Point Variable number

When a robot teaching position file number is selected from the table in part 1 of this Explanation, the following tag can be added or omitted.

No	Tag	Explanation	Note
10	T Point Variable number	Specifies the number of the point variable. The point variable manages the teaching positions registered in the job, and is used to move the manipulator to the same position several times in one job.	Available only with the optional point variable function.

8. VJ=Joint speed

The following tag can be added or omitted.

No	Tag	Explanation	Note
11	VJ=Joint speed	Specifies the joint speed. The joint speed is shown in the ratio to the highest speed. When the joint speed is omitted, the operation is performed at the speed decided beforehand.	Speed: 0.01% to 100.00% Variable B/B[]/LB/LB[]/I/I[]/LI/LI[]/D/D[]/LD/LD[] can be used. (Units: 0.01%)

9. PL=Position level /SPDL=Speed level

Choose one of the tags from the following table.

No	Tag	Explanation	Note
12	PL=Position level	Specifies the position level. The approach level when the manipulator passes the position where the teaching procedure was performed is called a positioning level.	Level: 0 to 8 Variable B/B[]/LB/LB[]/I/I[]/LI/LI[]/D/D[]/LD/LD[] can be used.
13	SPDL=Speed level	Specifies the speed level. The speed level is the tag for the robot to end the execution of the move instruction in the state of servo float control, and to confirm the state which has stopped. The operation ends when the speed feedback pulse of all axes goes below a constant value, and the manipulator is considered to have stopped.	Level: Only 0 Available only with the optional servo float function. Refer to the servo float function for details.



Position level

The approach level when the manipulator passes the position where the teaching procedure was performed is called a position level.

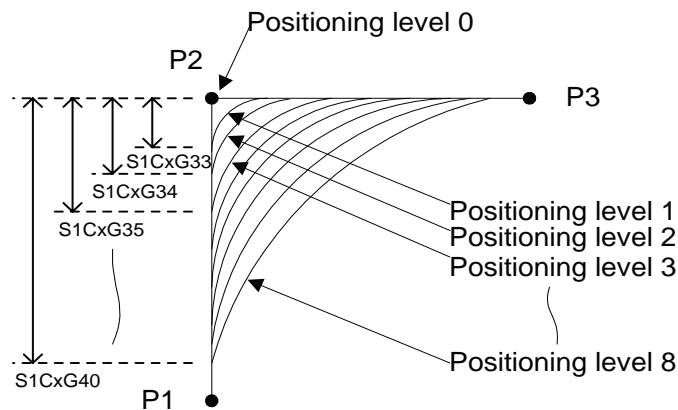

The approach level is set by the following parameters. (position zone)

- Position level 1 : S1CxG33(μm)
- Position level 2 : S1CxG34(μm)
- Position level 3 : S1CxG35(μm)
- Position level 4 : S1CxG36(μm)
- Position level 5 : SICxG37 (μm)
- Position level 6 : SICxG38 (μm)
- Position level 7 : SICxG39 (μm)
- Position level 8 : SICxG40 (μm)

2.4 Move Instruction

10. MT=Amount of the T axis rotation

The following tag can be added or omitted.

No	Tag	Explanation	Note
14	MT=Amount of the T axis rotation	Specifies the amount of the T axis rotation. The amount of the T axis rotation specifies the amount of movement of T axis by the number of rotations.	Amount of rotation: -100 to 100 Available only with the optional axis endless function. Refer to the axis endless function for details.

11. MTE= Amount of the station axis rotation

The following tag can be added or omitted.

No	Tag	Explanation	Note
15	MTE= Amount of the station axis rotation	Specifies the amount of the station axis rotation. The operation of the station axis can be specified by the number of rotations.	Amount of rotation: -100 to 100 Available only with the optional axis endless function.

12. NWAIT/ENWAIT

Choose one of the tags from the following table.

No	Tag	Explanation	Note
16	NWAIT	Specifies the NWAIT instruction. The NWAIT instruction carries out the instructions excluding the move instruction from that step on, at the same time as the manipulator is carrying out that step.	
17	ENWAIT	Specifies the ENWAIT instruction. The ENWAIT instruction carries out the instructions excluding the move instructions from that step on, before reaching the next step.	Available only with the conditional NWAIT function (option: S2C576) Refer to ENWAIT of "2.6 Instruction Which Adheres to an Instruction".

13. UNTIL/NSRCH

Choose one of the tags from the following table.

No	Tag	Explanation	Note
18	UNTIL	Specifies the UNTIL instruction. The UNTIL instruction is a tag instruction by which the condition of the input signal is evaluated during operation. When the condition of the input signal is full, the robot executes the next instruction.	Refer to UNTIL of "2.6. Instruction Which Adheres to Instruction".
19	NSRCH	Specifies the NSRCH instruction. The NSRCH instruction carries out the position detection without stopping the manipulator's motion.	Available only with the optional search-in-motion function.

14. ACC=Acceleration adjustment ratio

The following tag can be added or omitted.

No	Tag	Explanation	Note
20	ACC=Acceleration adjustment ratio	Specifies the acceleration adjustment ratio. The ACC instruction reduces the amount of acceleration in the specified ratio.	Acceleration adjustment ratio: 20% to 100% Variable B/B[]/LB/LB[]/I/I[]/LI/LI[]/D/D[]/LD/LD[] can be used.

15. DEC=Deceleration adjustment ratio

The following tag can be added or omitted.

No	Tag	Explanation	Note
21	DEC=Deceleration adjustment ratio	Specifies the deceleration adjustment ratio. The DEC instruction reduces the amount of deceleration in the specified ratio.	Deceleration adjustment ratio: 20% to 100% Variable B/B[]/LB/LB[]/I/I[]/LI/LI[]/D/D[]/LD/LD[] can be used.



Acceleration adjustment ratio

The acceleration adjustment ratio (ACC) reduces the amount of acceleration in the specified ratio.

Using this function can reduce the load inertia on the tool and the workpiece.

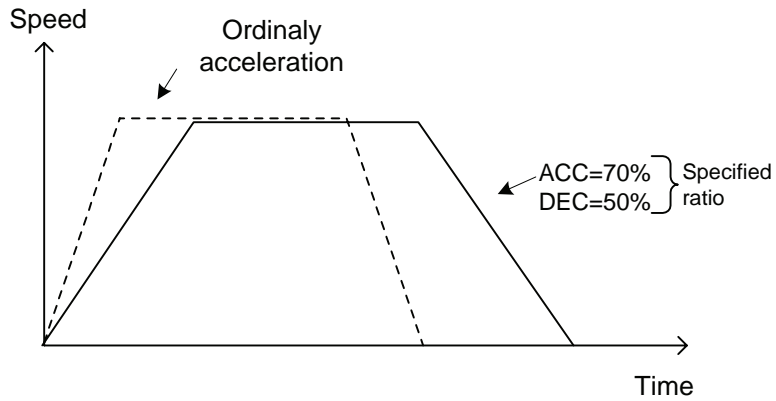

16. +MOVJ/+MOVL/+MOVC/+MOVS

Choose one of the tags from the following table.

No	Tag	Explanation	Note
22	+MOVJ	Specifies the joint interpolation motion instruction on the master manipulator's side.	Available only with the optional coordinate function. Refer to the independent/coordinated function.
23	+MOVL	Specifies the linear interpolation motion instruction on the master manipulator's side.	Available only with the optional coordinate function. Refer to the independent/coordinated function.
24	+MOVC	Specifies the circular interpolation motion instruction on the master manipulator's side.	Available only with the optional coordinate function. Refer to the independent/coordinated function.
25	+MOVS	Specifies the spline interpolation motion instruction on the master manipulator's side.	Available only with the optional coordinate function. Refer to the independent/coordinated function.

Example

MOVJ P000 VJ=50.00

Move from the manipulator's waiting position to step 1. Move by joint interpolation at a speed of 50%.

The position in Step 1 is registered to the P variable no. 0.

The path during movement is not specified. Be careful of interference.

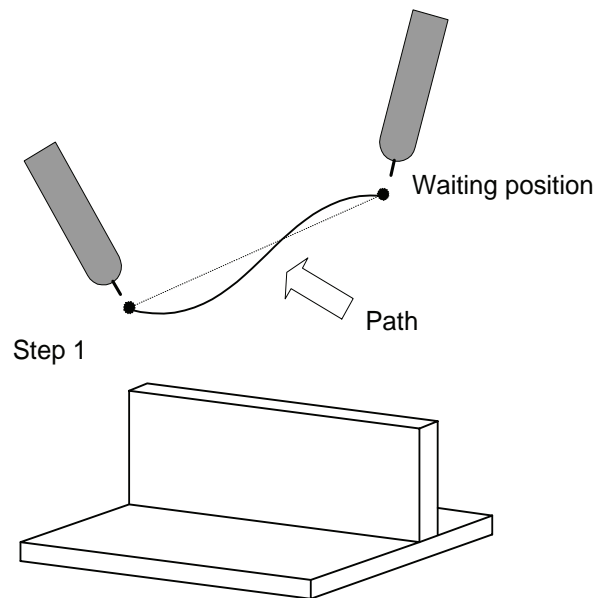

MOVL

Instruction set:

SUBSET	STANDARD	EXPANDED
Available	Available	Available

Function

Moves to the teaching position by linear interpolation.

Construction

The tag which can be used is limited by the type of the job.

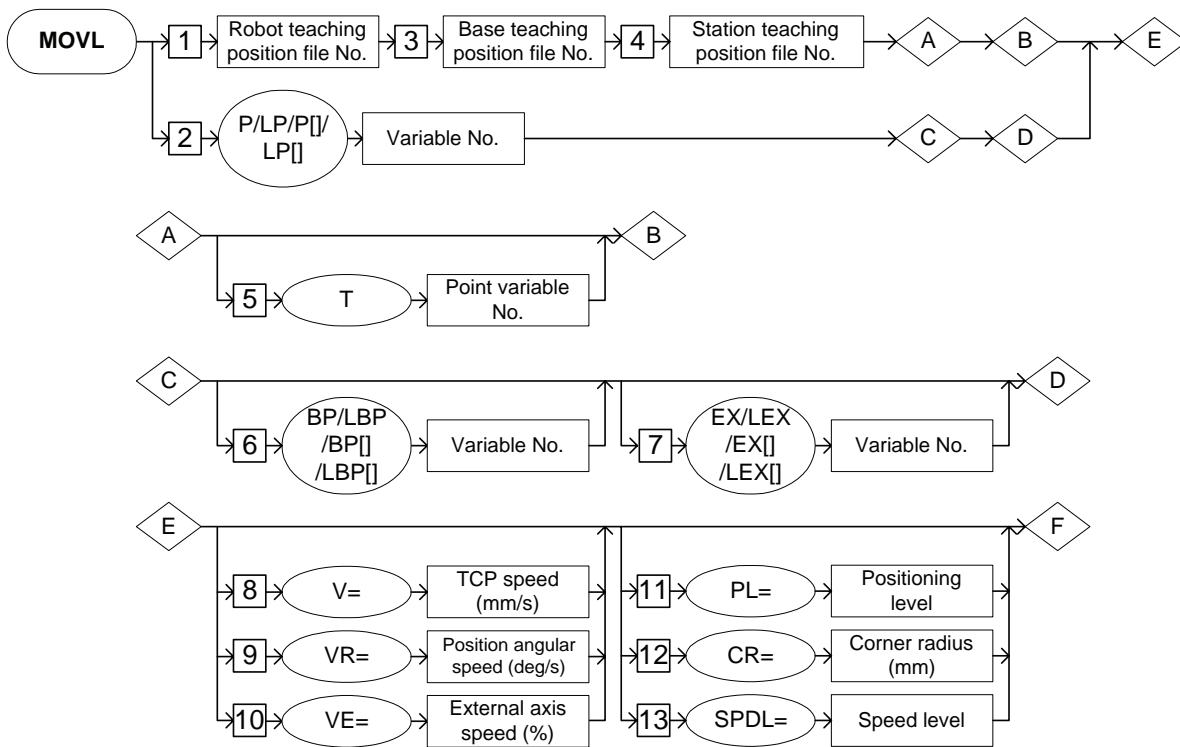

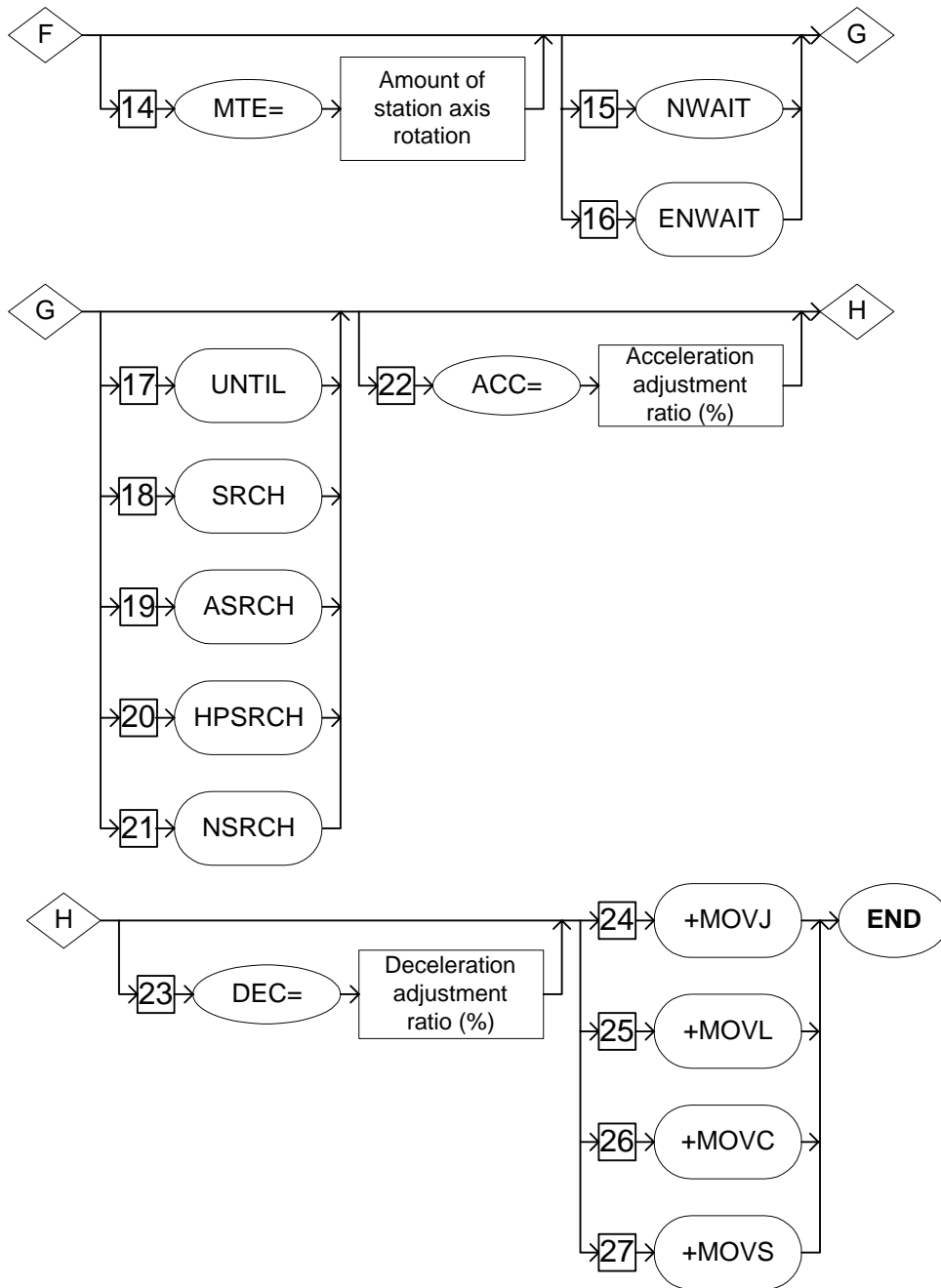

Job Type and Control Group

No.	Job Type	Control Group	Remarks
1	Single	One manipulator (standard)	
2	Single	One manipulator with base axis	
3	Single	One manipulator with station axis	
4	Single	One manipulator with base and station axes	
5	Coordinated	Two manipulators	Optional
6	Coordinated	Two manipulators with base axis	Optional

2.4 Move Instruction

Availability of Each Tag

No	Tag	Control Group						Note
		1	2	3	4	5	6	
1	Robot teaching position file number	●	●	●	●	●	●	
2	P/LP/P[]/LP[]	●	●	●	●	●	●	
3	Base teaching position file number	×	●	×	●	×	●	
4	Station teaching position file number	×	×	●	●	×	×	
5	T	○	○	○	○	○	○	Optional
6	BP/LBP/BP[]/LBP[]	×	●	×	●	×	●	
7	EX/LEX/EX[]/LEX[]	×	×	●	●	×	×	
8	V=	●	●	●	●	●	●	
9	VR=	●	●	●	●	●	●	
10	VE=	×	×	●	●	×	×	
11	PL=	●	●	●	●	●	●	
12	CR=	●	●	●	●	●	●	
13	SPDL=	○	○	○	○	○	○	Optional
14	MTE=	×	×	○	○	×	×	Optional
15	NWAIT	●	●	●	●	●	●	
16	ENWAIT	○	○	○	○	○	○	Optional
17	UNTIL	●	●	●	●	●	●	
18	SRCH	○	○	○	○	○	○	Optional
19	ASRCH	○	○	○	○	○	○	Optional
20	HPSRCH	○	○	○	○	○	○	Optional
21	NSRCH	○	○	○	○	○	○	Optional
22	ACC =	●	●	●	●	●	●	
23	DEC =	●	●	●	●	●	●	
24	+MOVJ	×	×	×	×	○	○	Optional
25	+MOVL	×	×	×	×	○	○	Optional
26	+MOVC	×	×	×	×	○	○	Optional
27	+MOVS	×	×	×	×	○	○	Optional

●: Available

○: Available only with optional function enabled

×: Not available

Explanation

1. Robot teaching position file number /P Variable number /LP Variable number /P [Array number] /LP [Array number]

Choose one of the tags from the following table.

No	Tag	Explanation	Note
1	Robot teaching position file number	The robot axis teaching position in each step is written in this file unconditionally when the step is taught. This teaching position cannot be edited.	On the job display, this tag is not displayed.
2	P Variable number/ LP Variable number/ P [Array number]/ LP [Array number]	Specifies the position variable number of the robot axis. Moves to the position data set in the variable of the specified number.	Variable number: 000 to 127

2. Base Teaching Position File Number

When a robot teaching position file number is selected from the table in part 1 of this Explanation, add the following tag.

No	Tag	Explanation	Note
3	Base teaching position file number	The base axis teaching position in each step is written in this file unconditionally when the step is taught. This teaching position cannot be edited.	On the job display, this tag is not displayed.

3. Station Teaching Position File Number

When a robot teaching position file number is selected from the table in part 1 of this Explanation, add the following tag.

No	Tag	Explanation	Note
4	Station teaching position file number	The station axis teaching position in each step is written in this file unconditionally when the step is taught. This teaching position cannot be edited.	On the job display, this tag is not displayed.

2.4 Move Instruction

4. T Point Variable number

When the robot teaching position file number is selected from the table in part 1 of this Explanation, the following can be added or omitted.

No	Tag	Explanation	Note
5	T Point Variable number	Specifies the point variable number. The point variable manages the teaching position registered in the job, and is used to move the manipulator to the same position several times in one job.	Available only with the optional point variable function.

5. BP Variable number /LBP Variable number /BP [Array number] /LBP [Array number]

When a P Variable number, LP Variable number, P [Array number], or LP [Array number] is selected from the table in part 1 of this Explanation, the following tag can be added.

No	Tag	Explanation	Note
6	BP Variable number/ LBP Variable number/ BP [Array number]/ LBP [Array number]	Specifies the position variable number of the base axis. Moves to the position data set in the variable of the specified number.	Variable number: 000 to 127

6. EX Variable number /LEX Variable number /EX [Array number] /LEX [Array number]

When a P Variable number, LP Variable number, P [Array number], or LP [Array number] is selected from the table in part 1 of this Explanation, the following tag can be added.

No	Tag	Explanation	Note
7	EX Variable number/ LEX Variable number/ EX [Array number]/ LEX [Array number]	Specifies the position variable number of the station axis. Moves to the position data set in the variable of the specified number.	Variable number: 000 to 127

7. V=Tool center point speed /VR=Position angular speed /VE=External axis speed

Choose one of the tags from the following table.

No	Tag	Explanation	Note
8	V=Tool center point speed	Specifies the tool center point speed.	Speed: 0.1 mm to 1500.0 mm/s The units can be changed by setting the parameter S2C173. Variable B/B[]/LB/LB[]/I/I[]/LI/LI[]/D/D[]/LD/LD[] can be used. (Units: 0.1 mm/s)
9	VR=Position angular speed	Specifies the position angular speed.	Speed: 0.1 to 180.0 degrees/s Variable B/B[]/LB/LB[]/I/I[]/LI/LI[]/D/D[]/LD/LD[] can be used. (Units: 0.1 deg./s)
10	VE=External axis speed	Specifies the external axis speed.	Speed: 0.01% to 100.00% Variable B/B[]/LB/LB[]/I/I[]/LI/LI[]/D/D[]/LD/LD[] can be used. (Units: 0.01 %)

8. PL=Position level /CR=Corner radius /SPDL=Speed level

Choose one of the tags from the following table.

No	Tag	Explanation	Note
11	PL=Position level	Specifies the position level. The position level is a level of the approach when the manipulator passes the position where the teaching procedure was performed.	Level: 0 to 8 Variable B/B[]/LB/LB[]/I/I[]/LI/LI[]/D/D[]/LD/LD[] can be used.
12	CR=Corner radius	Specifies the corner radius. The manipulator operates by circular interpolation in which the corner radius is specified.	Radius: 0.1mm to 6553.5 mm Variable B/B[]/LB/LB[]/I/I[]/LI/LI[]/D/D[]/LD/LD[] can be used. (Units: 0.1 mm)
13	SPDL=Speed level	Specifies the speed level. The speed level is the tag for the robot to end the execution of the move instruction in the state of the servo float control, and to confirm the state which has stopped. The operation ends when the speed feedback pulse of all axes goes below a constant value, and the manipulator is considered to have been stopped.	Level: Only 0 Available only with the optional servo-float function. Refer to the servo-float function for details.



Corner radius

The manipulator operates by circular interpolation in which the corner radius is specified.

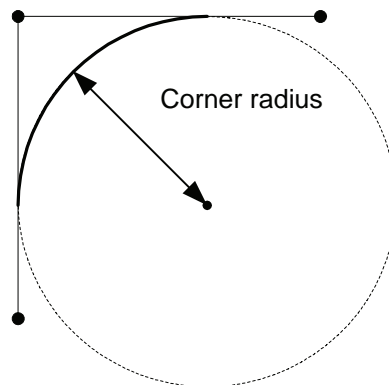

9. MTE= Amount of station axis rotation

The following tag can be added or omitted.

No	Tag	Explanation	Note
14	MTE=Amount of station axis rotation	Specifies the amount of station axis rotation. The operation of the station axis can be specified by the number of rotations.	Amount of rotation: -100 to 100 Available only with the optional axis endless function. Refer to the axis endless function for details.

10. NWAIT/ENWAIT

The following tag can be added or omitted.

No	Tag	Explanation	Note
15	NWAIT	Specifies the NWAIT instruction. The NWAIT instruction carries out the instructions excluding the move instruction from that step on, at the same as time the manipulator is carrying out that step.	
16	ENWAIT	Specifies the ENWAIT instruction. The ENWAIT instruction carries out the instructions excluding the move instructions from that step on, before reaching the next step.	Available only with the conditional NWAIT function. (option: S2C576) Refer to ENWAIT of "2.6 Instruction Which Adheres to an Instruction".

11. SRCH/UNTIL/ASRCH/HPSRCH/NSRCH

Choose one of the tags from the following table.

No	Tag	Explanation	Note
17	SRCH	Specifies the SRCH instruction. The SRCH instruction is a tag which detects the start point.	Available only with the optional start point searching function. Refer to " 2.6 Instruction Which Adheres to an Instruction ".
18	UNTIL	Specifies the UNTIL instruction. The UNTIL instruction is a tag by which the conditions of the input signal are evaluated during operation. When the condition of the input signal is full, the robot executes the next instruction.	Refer to " 2.6 Instruction Which Adheres to an Instruction ".
19	ASRCH	Specifies the ASRCH instruction. The ASRCH instruction detects input signal's voltage.	Available only with the optional general-purpose sensor function. Refer to General-purpose Sensor function for details.
20	HPSRCH	Specifies the HPSRCH instruction. The HPSRCH instruction detects the position of the zero-point.	Available only with the optional zero-point position detection function. Refer to the Zero-point Position Detection function for details.
21	NSRCH	Specifies the NSRCH instruction. The NSRCH instruction detects a position without stopping the motion.	Available only with the optional search-in-motion function.

12. ACC=Acceleration adjustment ratio

The following tag can be added or omitted.

No	Tag	Explanation	Note
22	ACC=Acceleration adjustment ratio	Specifies the acceleration adjustment ratio. The ACC instruction reduces the amount of acceleration in the specified ratio.	Acceleration adjustment ratio: 20% to 100% Variable B/B[]/LB/LB[]/I/I[]/LI/LI[]/D/D[]/LD/LD[] can be used.

13. DEC=Deceleration adjustment ratio

The following tag can be added or omitted.

No	Tag	Explanation	Note
23	DEC=Deceleration adjustment ratio	Specifies the deceleration adjustment ratio. The DEC instruction reduces the amount of deceleration in the specified ratio.	Deceleration adjustment ratio: 20% to 100% Variable B/B[]/LB/LB[]/I/I[]/LI/LI[]/D/D[]/LD/LD[] can be used.

14. +MOVJ/+MOVL/+MOVC/+MOVS

Choose one of the tags from the following table.

No	Tag	Explanation	Note
24	+MOVJ	Specifies the joint interpolation motion instruction on the master manipulator's side.	Available only with the optional coordinate function. Refer to the independent/coordinated function.
25	+MOVL	Specifies the linear interpolation motion instruction on the master manipulator's side.	Available only with the optional coordinate function. Refer to the independent/coordinated function.
26	+MOVC	Specifies the circular interpolation motion instruction on the master manipulator's side.	Available only with the optional coordinate function. Refer to the independent/coordinated function.
27	+MOVS	Specifies the spline interpolation motion instruction on the master manipulator's side.	Available only with the optional coordinate function. Refer to the independent/coordinated function.

Example

NOP

MOVJ VJ=50.00

MOVJ VJ=25.00

MOVJ VJ=12.50 • • • Step 3

MOVL V=138 • • • Step 4

Moves from Step 3 to Step 4 by the linear interpolation at a rate of 138cm/min.

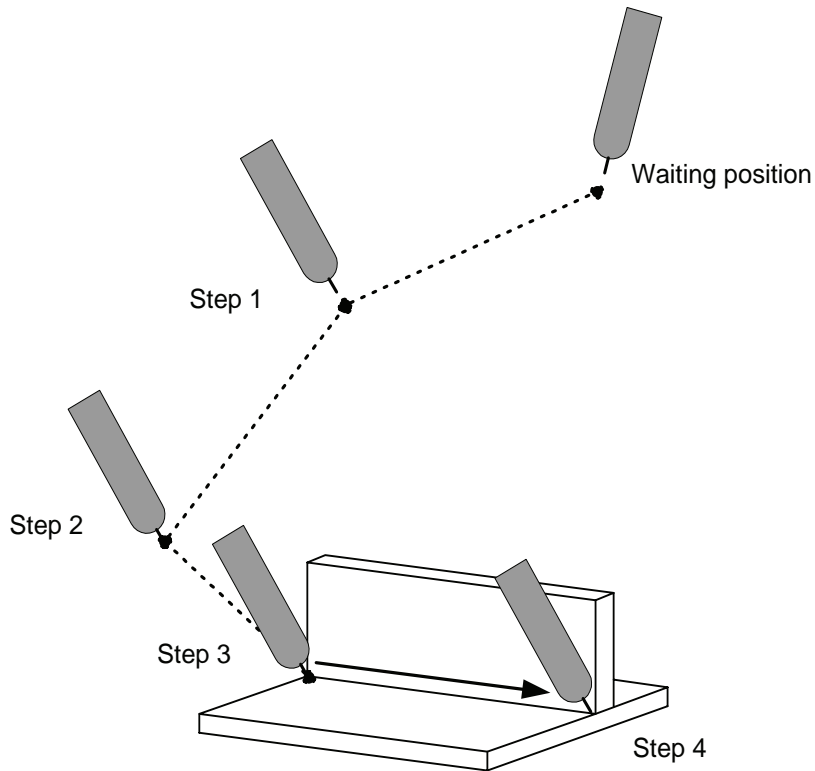

MOV C

Instruction set:

SUBSET	STANDARD	EXPANDED
Available	Available	Available

Function

Moves to the teaching position by circular interpolation.

Construction

The tag which can be used is limited by the type of the job.

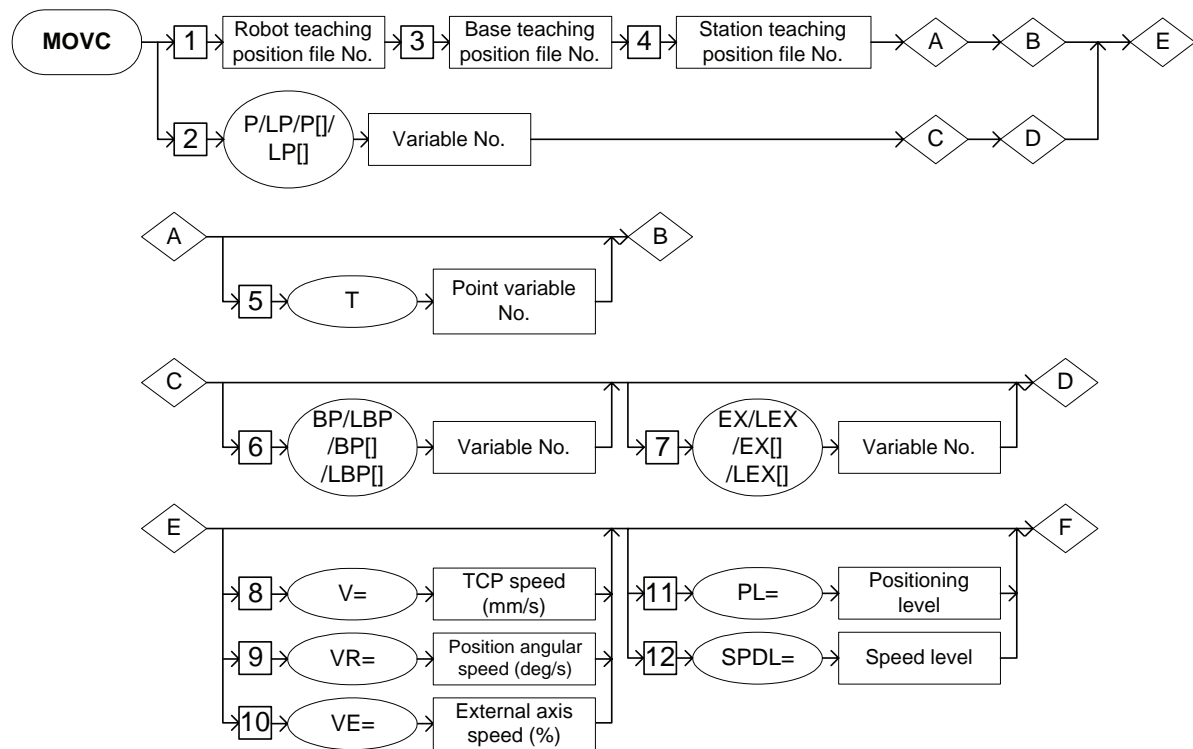

2.4 Move Instruction

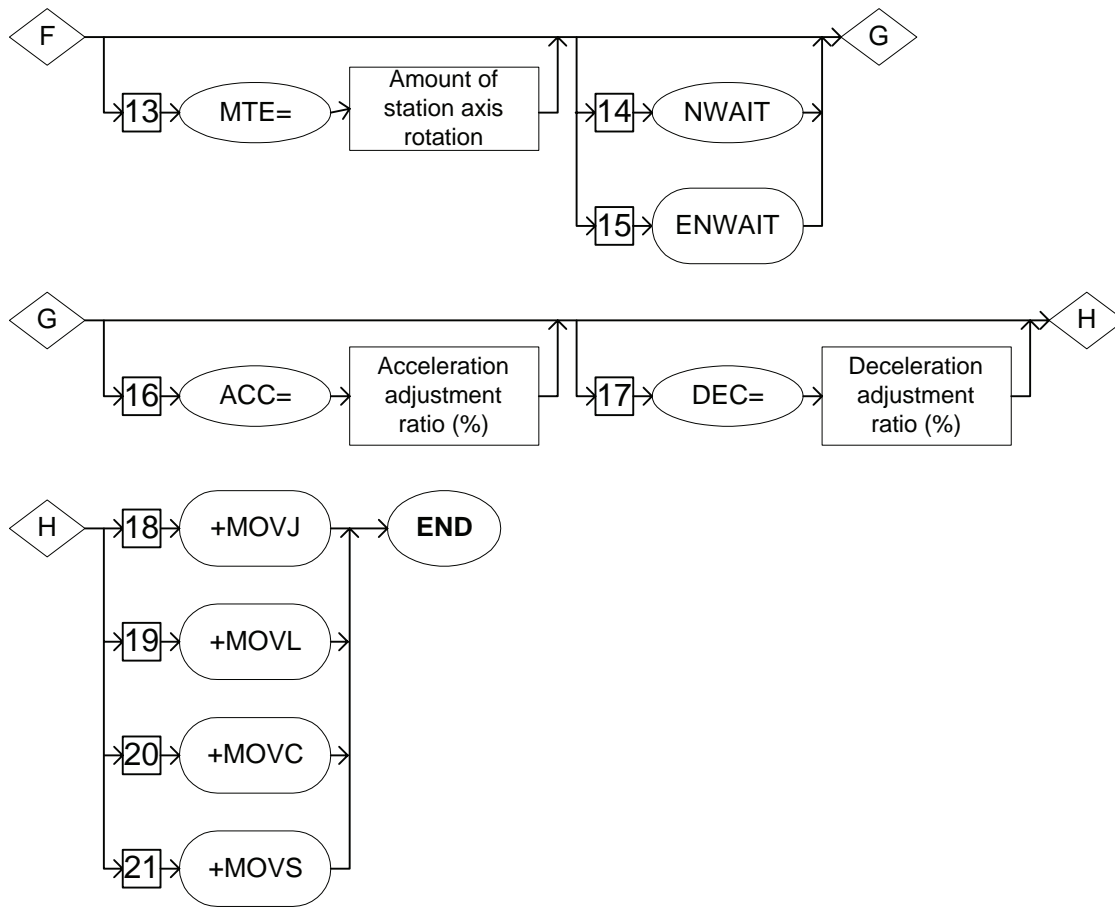

Job Type and Control Group

No.	Job Type	Control Group	Remarks
1	Single	One manipulator (standard)	
2	Single	One manipulator with base axis	
3	Single	One manipulator with station axis	
4	Single	One manipulator with base and station axes	
5	Coordinated	Two manipulators	Optional
6	Coordinated	Two manipulators with base axis	Optional

Availability of Each Tag

No	Tag	Control Group						Note
		1	2	3	4	5	6	
1	Robot teaching position file number	●	●	●	●	●	●	
2	P/LP/P[]/LP[]	●	●	●	●	●	●	
3	Base teaching position file number	×	●	×	●	×	●	
4	Station teaching position file number	×	×	●	●	×	×	
5	T	○	○	○	○	○	○	Optional
6	BP/LBP/BP[]/LBP[]	×	●	×	●	×	●	
7	EX/LEX/EX[]/LEX[]	×	×	●	●	×	×	
8	V=	●	●	●	●	●	●	
9	VR=	●	●	●	●	●	●	
10	VE=	×	×	●	●	×	×	
11	PL=	●	●	●	●	●	●	
12	SPDL=	○	○	○	○	○	○	Optional
13	MTE=	×	×	○	○	×	×	Optional
14	NWAIT	●	●	●	●	●	●	
15	ENWAIT	○	○	○	○	○	○	Optional
16	ACC=	●	●	●	●	●	●	
17	DEC =	●	●	●	●	●	●	
18	+MOVJ	×	×	×	×	○	○	Optional
19	+MOVL	×	×	×	×	○	○	Optional
20	+MOVC	×	×	×	×	○	○	Optional
21	+MOVS	×	×	×	×	○	○	Optional

●: Available

○: Available only with optional function enabled

×: Not available

2.4 Move Instruction

Explanation

1. Robot teaching position file number /P Variable number /LP Variable number /P [Array number] /LP [Array number]

Choose one of the tags from the following table.

No	Tag	Explanation	Note
1	Robot teaching position file number	The robot axis teaching position in each step is written in this file unconditionally when the step is taught. This teaching position cannot be edited.	On the job display, this tag is not displayed.
2	P Variable number/ LP Variable number/ P [Array number]/ LP [Array number]	Specifies the position variable number of the robot axis. Moves to the position data set in the variable of the specified number.	Variable number: 000 to 127

2. Base Teaching Position File Number

When a base teaching position file number is selected from the table in part 1 of this Explanation, added the following tag.

No	Tag	Explanation	Note
3	Base teaching position file number	The base axis teaching position in each step is written in this file unconditionally when the step is taught. This teaching position cannot be edited.	On the job display, this tag is not displayed.

3. Station Teaching Position File Number

When a base teaching position file number is selected from the table in part 1 of this Explanation, added the following tag.

No	Tag	Explanation	Note
4	Station teaching position file number	The station axis teaching position in each step is written in this file unconditionally when the step is taught. This teaching position cannot be edited.	On the job display, this tag is not displayed.

4. T Point Variable number

When the robot teaching position file number is selected from the table in part 1 of this Explanation, the following tag can be added or omitted.

No	Tag	Explanation	Note
5	T Point Variable number	Specifies the point variable number. The point variable manages the teaching position registered in the job, and is used to move the manipulator to the same position several times in one job.	Available only with the optional point variable function.

5. BP Variable number /LBP Variable number /BP [Array number] /LBP [Array number]

When a P Variable number, LP Variable number, P [Array number], or LP [Array number] is selected from the table in part 1 of this Explanation, the following tag can be added.

No	Tag	Explanation	Note
6	BP Variable number/ LBP Variable number/ BP [Array number]/ LBP [Array number]	Specifies the position variable number of the base axis. Moves to the position data set in the variable of the specified number.	Variable number: 000 to 127

6. EX Variable number /LEX Variable number /EX [Array number] /LEX [Array number]

When a P Variable number, LP Variable number, P [Array number], or LP [Array number] is selected from the table in part 1 of this Explanation, the following tag can be added.

No	Tag	Explanation	Note
7	EX Variable number/ LEX Variable number/ EX [Array number]/ LEX [Array number]	Specifies the position variable number of the station axis. Moves to the position data set in the variable of the specified number.	Variable number: 000 to 127

2.4 Move Instruction

7. V=Tool center point speed /VR=Position angular speed /VE=External axis speed

Choose one of the tags from the following table.

No	Tag	Explanation	Note
8	V=Tool center point speed	Specifies the tool center point speed.	Speed: 0.1 mm to 1500.0 mm/s The units can be changed by setting the parameter S2C173. Variable B/B[]/LB/LB[]/I/I[]/LI/LI[]/D/D[]/LD/LD[] can be used. (Units: 0.1 mm/s)
9	VR=Position angular speed	Specifies the position angular speed.	Speed: 0.1 degrees to 180.0 degrees/s Variable B/B[]/LB/LB[]/I/I[]/LI/LI[]/D/D[]/LD/LD[] can be used. (Units: 0.1 deg/s)
10	VE=External axis speed	Specifies the external axis speed.	Speed: 0.01% to 100.00% Variable B/B[]/LB/LB[]/I/I[]/LI/LI[]/D/D[]/LD/LD[] can be used. (Units: 0.01 %)

8. PL=Position level /SPDL=Speed level

Choose one of the tags from the following table.

No	Tag	Explanation	Note
11	PL=Position level	Specifies the position level. The position level is a level of the approach when the manipulator passes the position where the teaching procedure was performed.	Level: 0 to 8 Variable B/B[]/LB/LB[]/I/I[]/LI/LI[]/D/D[]/LD/LD[] can be used.
12	SPDL=Speed level	Specifies the speed level. The speed level is a tag for the robot to end the execution of the move instruction in the state of servo float control, and to confirm the state which has stopped. The operation ends when the speed feedback pulse of all axes goes below a constant value, and the manipulator is considered to have been stopped.	Level: Only 0 Available only with the optional servo-float function.

9. MTE=Amount of station axis rotation

The following tag can be added or omitted.

No	Tag	Explanation	Note
13	MTE=Amount of station axis rotation	Specifies the amount of station axis rotation. The operation of the station axis can be specified by the number of rotations.	Amount of rotation: -100 to 100 Available only with the optional axis endless function.

10. NWAIT/ENWAIT

The following tag can be added or omitted.

No	Tag	Explanation	Note
14	NWAIT	Specifies the NWAIT instruction. The NWAIT instruction carries out the instructions excluding the move instruction from that step on, at the same time as the manipulator is carrying out that step.	
15	ENWAIT	Specifies the ENWAIT instruction. The ENWAIT instruction carries out the instructions excluding the move instructions from that step on, before reaching the next step.	Available only with the conditional NWAIT function. (option: S2C576) Refer to ENWAIT of "2.6 Instruction Which Adheres to an Instruction".

11. ACC=Acceleration adjustment ratio

The following tag can be added or omitted.

No	Tag	Explanation	Note
16	ACC=Acceleration adjustment ratio	Specifies the acceleration adjustment ratio. The ACC instruction reduces the amount of acceleration in the specified ratio.	Acceleration adjustment ratio: 20% to 100% Variable B/B[]/LB/LB[]/I/I[]/LI/LI[]/D/D[]/LD/LD[] can be used.

2.4 Move Instruction

12. DEC=Deceleration adjustment ratio

The following tag can be added or omitted.

No	Tag	Explanation	Note
17	DEC=Deceleration adjustment ratio	Specifies the deceleration adjustment ratio. The DEC instruction reduces the amount of deceleration in the specified ratio.	Deceleration adjustment ratio: 20% to 100% Variable B/B[]/LB/LB[]/I/I[]/LI/LI[]/D/D[]/LD/LD[] can be used.

13. +MOVJ/+MOVL/+MOVC/+MOVS

Choose one of the tags from the following table.

No	Tag	Explanation	Note
18	+MOVJ	Specifies the joint interpolation motion instruction on the master manipulator's side.	Available only with the optional coordinate function. Refer to the independent/coordinated function.
19	+MOVL	Specifies the linear interpolation motion instruction on the master manipulator's side.	Available only with the optional coordinate function. Refer to the independent/coordinated function.
20	+MOVC	Specifies the circular interpolation motion instruction on the master manipulator's side.	Available only with the optional coordinate function. Refer to the independent/coordinated function.
21	+MOVS	Specifies the spline interpolation motion instruction on the master manipulator's side.	Available only with the optional coordinate function. Refer to the independent/coordinated function.

Example

```
NOP
MOVL V=138
MOVC V=138 • • • Step 2
MOVC V=138 • • • Step 3
MOVC V=138 • • • Step 4
MOVC V=138 • • • Step 5
MOVL V=138
END
```

Moves from Step 2 to Step 5 by circular interpolation at a rate of 138 cm/min.

Moves to Step 3 in a circular arc formed with the teaching points in Steps 2, 3, and 4.

Moves to Step 4 in a circular arc formed with the teaching points in Steps 3, 4, and 5.

Moves to Step 5 in a circular arc formed with the teaching points in Steps 3, 4, and 5.

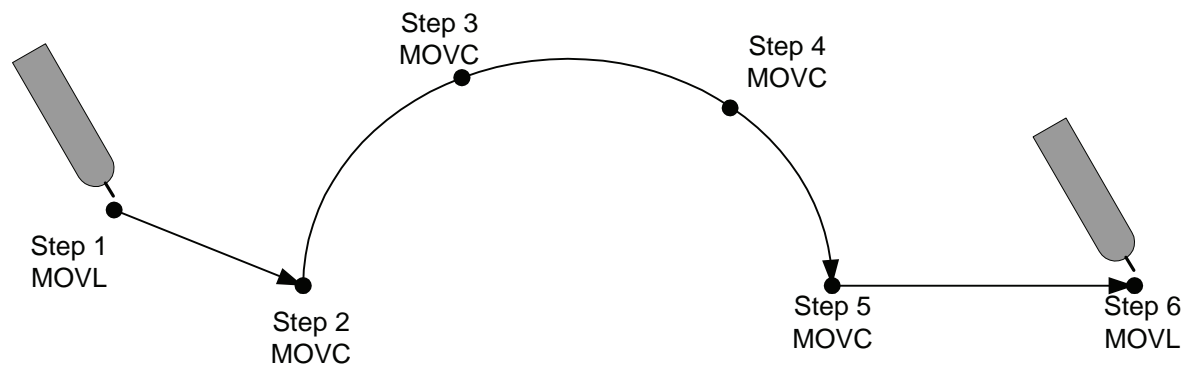

MOVS

Instruction set:

SUBSET	STANDARD	EXPANDED
Available	Available	Available

Function

Moves to the teaching position by spline interpolation.

Construction

The tag which can be used is limited by the type of the job.

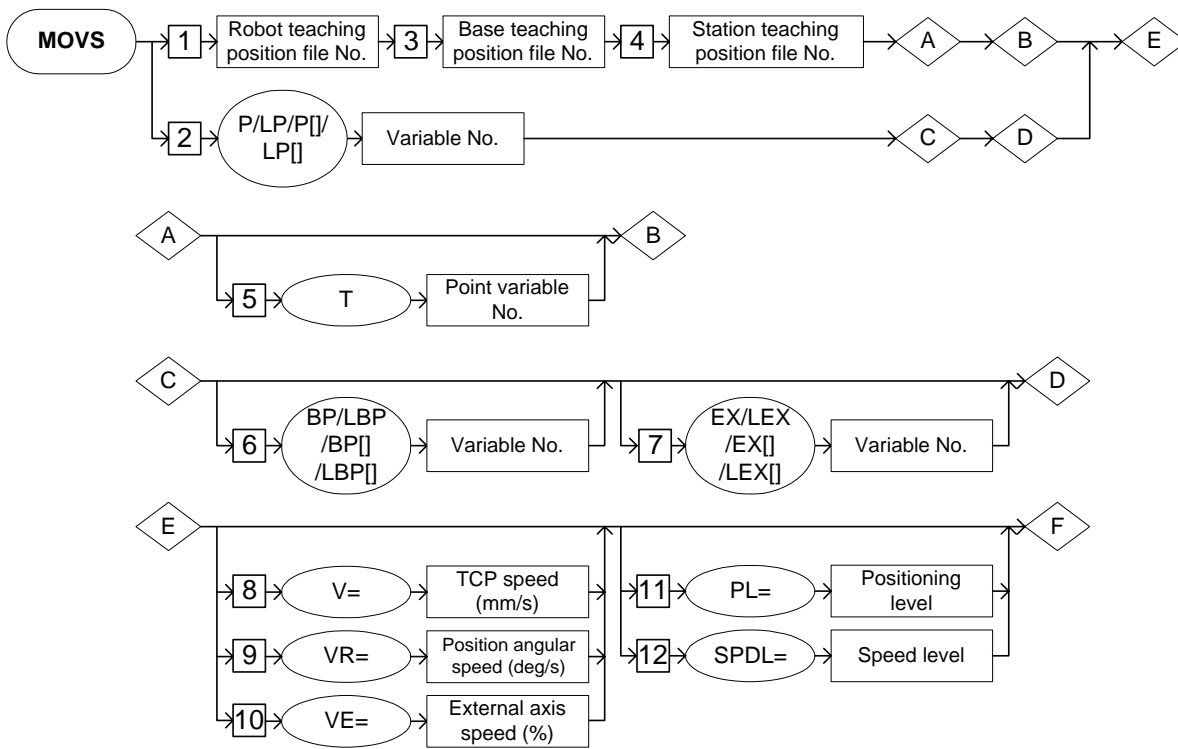

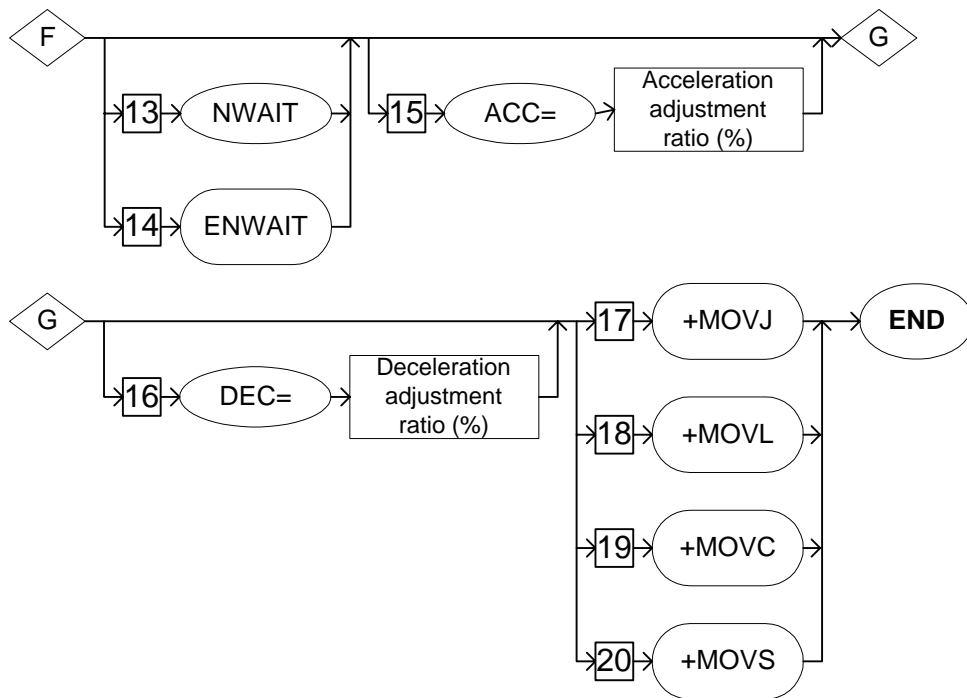

Job Type and Control Group

No.	Job type	Control Group	Remarks
1	Single	One manipulator (standard)	
2	Single	One manipulator with base axis	
3	Single	One manipulator with station axis	
4	Single	One manipulator with base and station axes	
5	Coordinated	Two manipulators	Optional
6	Coordinated	Two manipulators with base axis	Optional

Availability of Each Tag

No	Tag	Control Group						Note
		1	2	3	4	5	6	
1	Robot teaching position file number	●	●	●	●	●	●	
2	P/LP/P[]/LP[]	●	●	●	●	●	●	
3	Base teaching position file number	×	●	×	●	×	●	
4	Station teaching position file number	×	×	●	●	×	×	
5	T	○	○	○	○	○	○	Optional
6	BP/LBP/BP[]/LBP[]	×	●	×	●	×	●	
7	EX/LEX/EX[]/LEX[]	×	×	●	●	×	×	
8	V=	●	●	●	●	●	●	
9	VR=	●	●	●	●	●	●	
10	VE=	×	×	●	●	×	×	
11	PL=	●	●	●	●	●	●	
12	SPDL=	○	○	○	○	○	○	Optional
13	NWAIT	●	●	●	●	●	●	
14	ENWAIT	○	○	○	○	○	○	Optional
15	ACC =	●	●	●	●	●	●	
16	DEC =	●	●	●	●	●	●	
17	+MOVJ	×	×	×	×	○	○	Optional
18	+MOVL	×	×	×	×	○	○	Optional
19	+MOVCC	×	×	×	×	○	○	Optional
20	+MOVSS	×	×	×	×	○	○	Optional

●: Available

○: Available only with optional function enabled

×: Not available

Explanation

1. Robot teaching position file number /P Variable number /LP Variable number /P [Array number] /LP [Array number]

Choose one of the tags from the following table.

No	Tag	Explanation	Note
1	Robot teaching position file number	The robot axis teaching position in each step is written in this file unconditionally when the step is taught. This teaching position cannot be edited.	On the job display, this tag is not displayed.
2	P Variable number / LP Variable number / P [Array number]/ LP [Array number]	Specifies the position variable number of the robot axis. Moves to the position data set in the variable of the specified number.	Variable number: 000 to 127

2. Base Teaching Position File Number

When a robot teaching position file number is selected from the table in part 1 of this Explanation, add the following tag.

No	Tag	Explanation	Note
3	Base teaching position file number	The base axis teaching position in each step is written in this file unconditionally when the step is taught. This teaching position cannot be edited.	On the job display, this tag is not displayed.

3. Station Teaching Position File Number

When a robot teaching position file number is selected from the table in part 1 of this Explanation, add the following tag.

No	Tag	Explanation	Note
4	Station teaching position file number	The station axis teaching position in each step is written in this file unconditionally when the step is taught. This teaching position cannot be edited.	On the job display, this tag is not displayed.

2.4 Move Instruction

4. T Point Variable number

When the robot teaching position file number is selected from the table in part 1 of this Explanation, the following tag can be added or omitted.

No	Tag	Explanation	Note
5	T Point Variable number	Specifies the point variable number. The point variable manages the teaching position registered in the job, and is used to move the manipulator to the same position several times in one job.	Available only with the optional point variable function.

5. BP Variable number /LBP Variable number /BP [Array number] /LBP [Array number]

When a P Variable number, LP Variable number, P [Array number], or LP [Array number] is selected from the table in part 1 of this Explanation, the following tag can be added.

No	Tag	Explanation	Note
6	BP Variable number / LBP Variable number / BP [Array number]/ LBP [Array number]	Specifies the position variable number of the base axis. Moves to the position data set in the variable of the specified number.	Variable number: 000 to 127

6. EX Variable number /LEX Variable number /EX [Array number] /LEX [Array number]

When a P Variable number, LP Variable number, P [Array number], or LP [Array number] is selected from the table in part 1 of this Explanation, the following tag can be added.

No	Tag	Explanation	Note
7	EX Variable number / LEX Variable number / EX [Array number]/ LEX [Array number]	Specifies the position variable number of the station axis. Moves to the position data set in the variable of the specified number.	Variable number: 000 to 127

7. V=Tool center point speed /VR=Position angular speed /VE=External axis speed

Choose one of the tags from the following table.

No	Tag	Explanation	Note
8	V=Tool center point speed	Specifies the tool center point speed.	Speed: 0.1 mm to 1500.0 mm/s The units can be changed by setting the parameter S2C173. Variable B/B[]/LB/LB[]/I/I[]/LI/LI[]/D/D[]/LD/LD[] can be used. (Units: 0.1 mm/s)
9	VR=Position angular speed	Specifies the position angular speed.	Speed: 0.1 degrees to 180.0 degrees/s Variable B/B[]/LB/LB[]/I/I[]/LI/LI[]/D/D[]/LD/LD[] can be used. (Units: 0.1 deg/s)
10	VE=External axis speed	Specifies the external axis speed.	Speed: 0.01% to 100.00% Variable B/B[]/LB/LB[]/I/I[]/LI/LI[]/D/D[]/LD/LD[] can be used. (Units: 0.01 %)

8. PL=Position level /SPDL=Speed level

Choose one of the tags from the following table.

No	Tag	Explanation	Note
11	PL=Position level	Specifies the position level. The position level is a level of the approach when the manipulator passes the position where the teaching procedure was done.	Level: 0 to 8 Variable B/B[]/LB/LB[]/I/I[]/LI/LI[]/D/D[]/LD/LD[] can be used.
12	SPDL=Speed level	Specifies the speed level. The speed level is a tag for the robot to end the execution of the move instruction in the state of servo float control, and to confirm the state which has stopped. The operation ends when the speed feedback pulse of all axes goes below a constant value, and the manipulator is considered to have been stopped.	Level: Only 0 Available only with the optional servo-float function.

2.4 Move Instruction

9. NWAIT/ENWAIT

The following tag can be added or omitted.

No	Tag	Explanation	Note
13	NWAIT	Specifies the NWAIT instruction. The NWAIT instruction carries out the instructions excluding the move instruction from that step on, at the same time as the manipulator is carrying out that step.	
14	ENWAIT	Specifies the ENWAIT instruction. The ENWAIT instruction carries out the instructions excluding the move instructions from that step on, before reaching the next step.	Available only with the conditional NWAIT function. (option: S2C576) Refer to ENWAIT of "2.6 Instruction Which Adheres to an Instruction".

10. ACC=Acceleration adjustment ratio

The following tag can be added or omitted.

No	Tag	Explanation	Note
15	ACC=Acceleration adjustment ratio	Specifies the acceleration adjustment ratio. The ACC instruction reduces the amount of acceleration in the specified ratio.	Acceleration adjustment ratio: 20% to 100% Variable B/B[]/LB/LB[]/I/I[]/LI/LI[]/D/D[]/LD/LD[] can be used.

11. DEC=Deceleration adjustment ratio

The following tag can be added or omitted.

No	Tag	Explanation	Note
16	DEC=Deceleration adjustment ratio	Specifies the deceleration adjustment ratio. The DEC instruction reduces the amount of deceleration in the specified ratio.	Deceleration adjustment ratio: 20% to 100% Variable B/B[]/LB/LB[]/I/I[]/LI/LI[]/D/D[]/LD/LD[] can be used.

12. +MOVJ/+MOVL/+MOVC/+MOVS

Choose one of the tags from the following table.

No	Tag	Explanation	Note
17	+MOVJ	Specifies the joint interpolation motion instruction on the master manipulator's side.	Available only with the optional coordinate function. Refer to the independent/coordinated function.
18	+MOVL	Specifies the linear interpolation motion instruction on the master manipulator's side.	Available only with the optional coordinate function. Refer to the independent/coordinated function.
19	+MOVC	Specifies the circular interpolation motion instruction on the master manipulator's side.	Available only with the optional coordinate function. Refer to the independent/coordinated function.
20	+MOVS	Specifies the spline interpolation motion instruction on the master manipulator's side.	Available only with the optional coordinate function. Refer to the independent/coordinated function.

Example

NOP

```
MOVL V=138  
MOVS V=138 • • • Step 2  
MOVS V=138 • • • Step 3  
MOVS V=138 • • • Step 4  
MOVS V=138 • • • Step 5  
MOVS V=138 • • • Step 6  
MOVL V=138  
END
```

Moves from Step 2 to Step 6 by spline interpolation at a rate of 138cm/min.
Moves to Step 3 by spline interpolation defined by the teaching points in Steps 2, 3, and 4.
Moves to Step 4 by synchronized spline interpolation defined by the teaching points in Steps 2, 3, 4 and by the synchronized spline interpolation defined by the teaching points in Steps 3, 4, and 5.
Moves to Step 5 by synchronized spline interpolation defined by the teaching points in Steps 3, 4,5 and by synchronized spline interpolation defined by the teaching points in Steps 4, 5, and 6.
Moves to Step 6 by spline interpolation defined by the teaching points in Steps 4, 5, and 6.

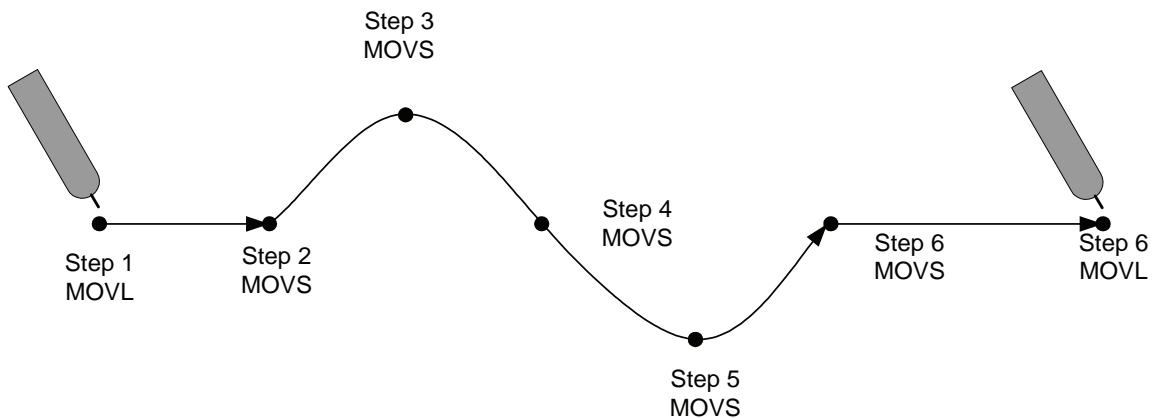

IMOV

Instruction set:

SUBSET	STANDARD	EXPANDED
Available	Available	Available

Function

Moves by linear interpolation from the current position for the specified incremental value.

Construction

The tag which can be used is limited by the type of the job.

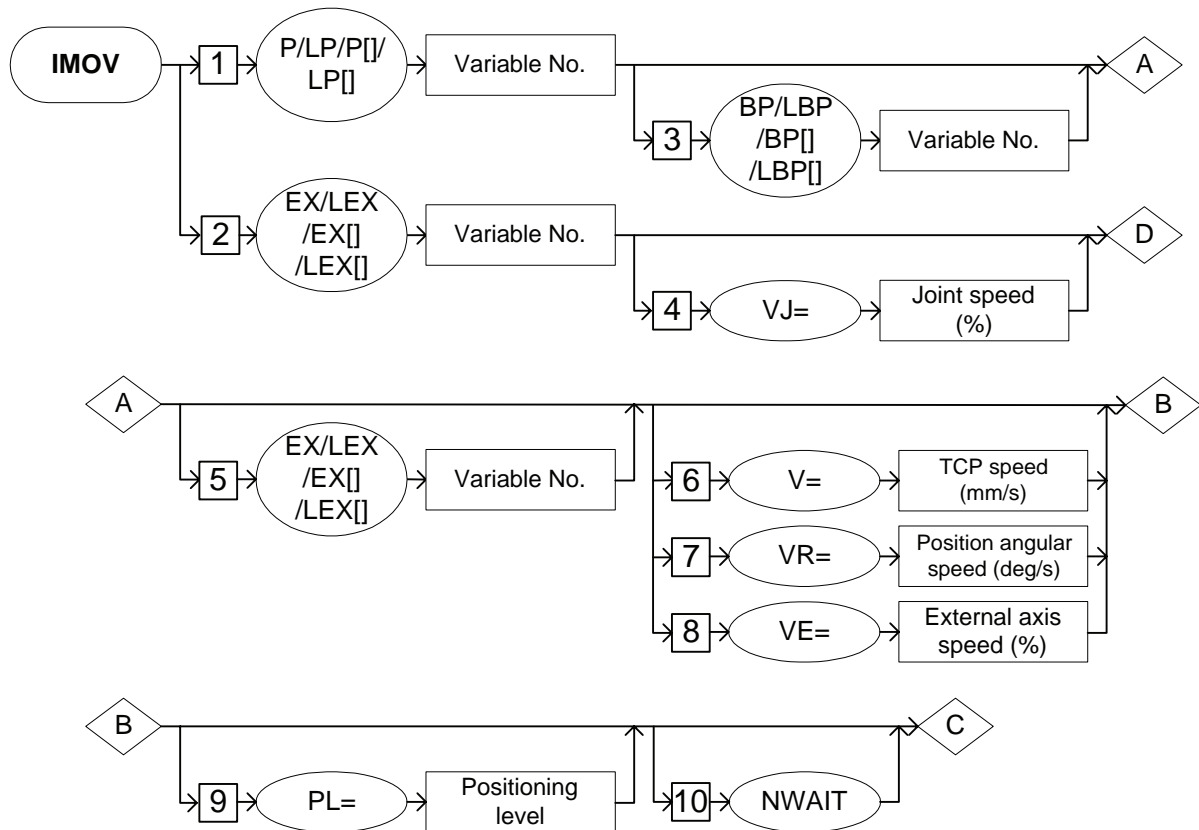

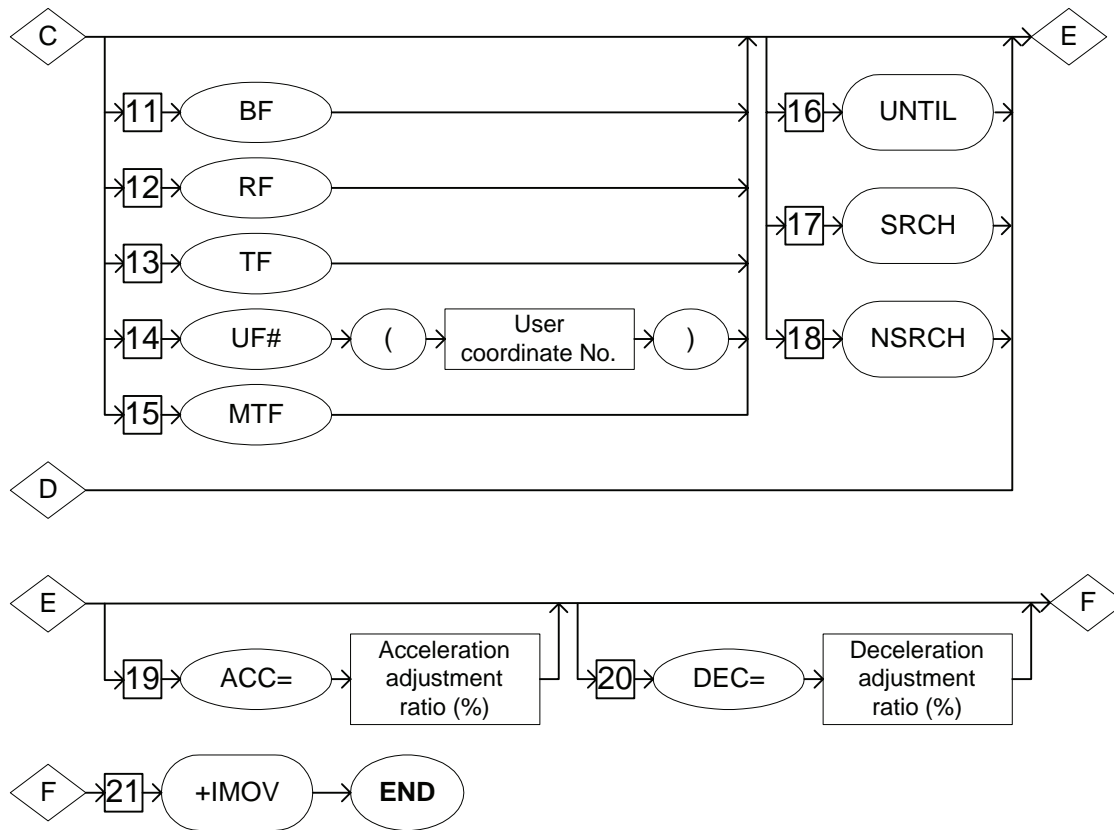

Job Type and Control Group

No.	Job Type	Control Group	Remarks
1	Single	One manipulator (standard)	
2	Single	One manipulator with base axis	
3	Single	One manipulator with station axis	
4	Single	One manipulator with base and station axes	
5	Single	Only station axis	
6	Coordinated	Two manipulators	Optional
7	Coordinated	Two manipulators with base axis	Optional

Availability of Each Tag

No	Tag	Control Group							Note
		1	2	3	4	5	6	7	
1	P/LP/P[]/LP[]	●	●	●	●	×	●	●	
2	EX/LEX/EX[]/LEX[]	×	×	×	×	●	×	×	
3	BP/LBP/BP[]/LBP[]	×	●	×	●	×	×	●	
4	VJ=	×	×	×	×	●	×	×	
5	EX/LEX/EX[]/LEX[]	×	×	●	●	×	×	×	
6	V=	●	●	●	●	×	●	●	
7	VR=	●	●	●	●	×	●	●	
8	VE=	×	×	●	●	×	×	×	
9	PL=	●	●	●	●	×	●	●	
10	NWAIT	●	●	●	●	×	●	●	
11	BF	●	●	●	●	×	●	●	
12	RF	●	●	●	●	×	●	●	
13	TF	●	●	●	●	×	●	●	
14	UF#()	●	●	●	●	×	●	●	
15	MTF	×	×	×	×	×	●	●	
16	UNTIL	●	●	●	●	×	●	●	
17	SRCH	○	○	○	○	×	○	○	Optional
18	NSRCH	○	○	○	○	×	○	○	Optional
19	ACC =	●	●	●	●	●	●	●	
20	DEC =	●	●	●	●	●	●	●	
21	+IMOV	×	×	×	×	×	○	○	Optional

●: Available

○: Available only with optional function enabled

×: Not available

Explanation

1. P Variable number /LP Variable number /P [Array number] /LP [Array number] /EX Variable number /LEX Variable number /EX [Array number] /LEX [Array number]

Choose one of the tags from the following table.

No	Tag	Explanation	Note
1	P Variable number / LP Variable number / P [Array number]/ LP [Array number]	Specifies the position variable number of the manipulator axis. Moves the axis according to the position data set in the specified variable number.	Variable number: 000 to 127
2	EX Variable number / LEX Variable number / EX [Array number]/ LEX [Array number]	Specifies the position variable number of the station axis. Moves the axis according to the position data set in the specified variable number.	Variable number: 000 to 127

2. BP Variable number /LBP Variable number /BP [Array number] /LBP [Array number]

When a P Variable number, LP Variable number, P [Array number], or LP [Array number] is selected from the table in part 1 of this Explanation, the following tag can be added.

No	Tag	Explanation	Note
3	BP Variable number / LBP Variable number / BP [Array number]/ LBP [Array number]	Specifies the position variable number of the base axis. Moves the axis according to the position data set in the specified variable number.	Variable number: 000 to 127

3. VJ=Joint speed

The following tag can be added or omitted.

No	Tag	Explanation	Note
4	VJ=Joint speed	Specifies the joint speed. The joint speed in a ratio to the highest speed. Operates at the speed decided beforehand when the joint speed is omitted.	Speed: 0.01% to 100.00% Variable B/B[]/LB/LB[]/I/I[]/L/LI[]/D/D[]/LD/LD[] can be used. (Units: 0.01 %)

4. EX Variable number /LEX Variable number /EX [Array number] /LEX [Array number]

When a P Variable number, LP Variable number, P [Array number], or LP [Array number] is selected from the table in part 1 of this Explanation, the following tag can be added.

No	Tag	Explanation	Note
5	EX Variable number / LEX Variable number / EX [Array number]/ LEX [Array number]	Specifies the position variable number of the station axis. Moves the axis according to the position data set in the specified variable number.	Variable number: 000 to 127

2.4 Move Instruction

5. V=Tool center point speed /VR=Position angular speed /VE=External axis speed

Choose one of the tags from the following table.

No	Tag	Explanation	Note
6	V=Tool center point speed	Specifies the tool center point speed.	Speed: 0.1 mm to 1500.0 mm/s The units can be changed by setting the parameter S2C173. Variable B/B[]/LB/LB[]/I/I[]/LI/LI[]/D/D[]/LD/LD[] can be used. (Units: 0.1 mm/s)
7	VR=Position angular speed	Specifies the position angular speed.	Speed: 0.1 degrees to 180.0 degrees/s Variable B/B[]/LB/LB[]/I/I[]/LI/LI[]/D/D[]/LD/LD[] can be used. (Units: 0.1 deg/s)
8	VE=External axis speed	Specifies the external axis speed.	Speed: 0.01% to 100.00% Variable B/B[]/LB/LB[]/I/I[]/LI/LI[]/D/D[]/LD/LD[] can be used. (Units: 0.01 %)

6. PL=Position level

The following tag can be added or omitted.

No	Tag	Explanation	Note
9	PL=Position level	Specifies the position level. The positioning level is a level of the approach when the manipulator passes the position where the teaching procedure was done.	Level: 0 to 8 Variable B/B[]/LB/LB[]/I/I[]/LI/LI[]/D/D[]/LD/LD[] can be used.

7. NWAIT

The following tag can be added or omitted.

No	Tag	Explanation	Note
10	NWAIT	Specifies the NWAIT instruction. The NWAIT instruction carries out the instructions excluding the move instruction from that step on, at the same as time the manipulator is carrying out that step.	

8. BF/RF/TF/UF# (User coordinate number)

Choose one of the tags from the following table.

No	Tag	Explanation	Note
11	BF	Specifies the increment value in the base coordinate system.	
12	RF	Specifies the increment value in the robot coordinate system.	
13	TF	Specifies the increment value in the tool coordinate system.	
14	UF#(User coordinate number)	Specifies the increment value in the user coordinate system.	No: 1 to 24 Variable B/I/D/LB/LI/LD can be used.
15	MTF	Specifies the incremental value in the master tool coordinate system. In the master tool coordinate system, position data is converted to positions relative to the master manipulator.	Available only with the optional independent/coordinated function.

9. UNTIL/SRCH/NSRCH

Choose one of the tags from the following table.

No	Tag	Explanation	Note
16	UNTIL	Specifies the UNTIL instruction. The UNTIL instruction is a tag by which the conditions of the input signal are evaluated during operation. When the condition of the input signal is full, the robot executes the next instruction.	Refer to " 2.6 Instruction Which Adheres to an Instruction ".
17	SRCH	Specifies the SRCH instruction. The SRCH instruction is a tag which detects the start point.	Available only with the optional start point searching function. Refer to " 2.6 Instruction Which Adheres to an Instruction ".
18	NSRCH	Specifies the NSRCH instruction. The NSRCH instruction detects a position without stopping the motion.	Available only with the optional search-in-motion function.

2.4 Move Instruction

10. ACC=Acceleration adjustment ratio

The following tag can be added or omitted.

No	Tag	Explanation	Note
19	ACC=Acceleration adjustment ratio	Specifies the acceleration adjustment ratio. The ACC instruction reduces the amount of acceleration in the specified ratio.	Acceleration adjustment ratio: 20% to 100% Variable B/B[]/LB/LB[]/I/I[]/LI/LI[]/D/D[]/LD/LD[] can be used.

11. DEC=Deceleration adjustment ratio

The following tag can be added or omitted.

No	Tag	Explanation	Note
20	DEC=Deceleration adjustment ratio	Specifies the deceleration adjustment ratio. The DEC instruction reduces the amount of deceleration in the specified ratio.	Deceleration adjustment ratio: 20% to 100% Variable B/B[]/LB/LB[]/I/I[]/LI/LI[]/D/D[]/LD/LD[] can be used.

12. +IMOV

Add the following tag.

No	Tag	Explanation	Note
22	+IMOV	Specifies the move instruction for an incremental value of the master manipulator.	Available only with the optional coordinate function. Refer to the independent/coordinated function for details.

Example

IMOV P000 V=138 RF

Moves from the current position at a rate of 138cm/min for the incremental value specified in P000 in the robot coordinate system.

SPEED

Instruction set:

SUBSET	STANDARD	EXPANDED
Available	Available	Available

Function

Sets the playback speed. The manipulator operates at the speed specified in the SPEED instruction when the speed is not specified in the move instruction.

Construction

The tag which can be used is limited by the type of the job.

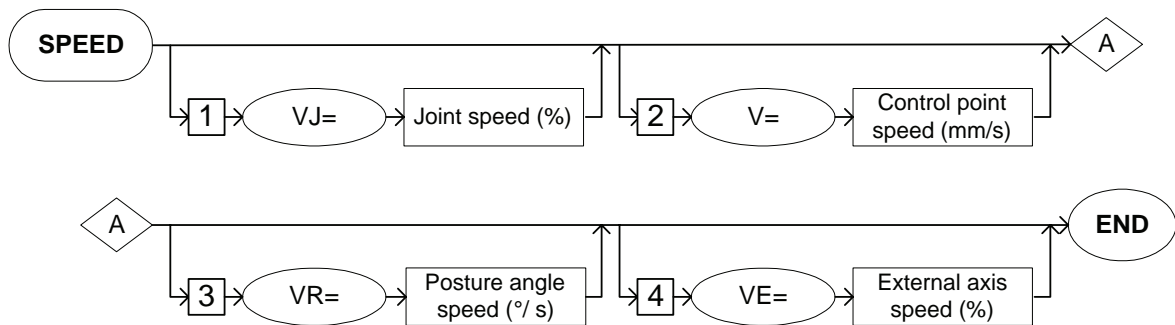

Job Type and Control Group

No.	Job Type	Control group	Remarks
1	-	One manipulator (standard)	
2	-	One manipulator with station axis	
3	-	Station axis only	

Availability of Each Tag

No	Tag	Control Group			Note
		1	2	3	
1	VJ=	●	●	●	
2	V=	●	●	×	
3	VR=	●	●	×	
4	VE=	×	●	×	

●: Available
×: Not available

2.4 Move Instruction

Explanation

1. VJ=Joint speed

The following tag can be added or omitted.

No	Tag	Explanation	Note
1	VJ=Joint speed	Specifies the joint speed. The joint speed is shown in the ratio to the highest speed. Operates at the speed decided beforehand when the joint speed is omitted.	Speed: 0.01% to 100.00% Variable B/B[]/LB/LB[]/I/I[]/LI/LI[]/D/D[]/LD/LD[] can be used. (Units: 0.01 %)

2. V=Tool center point speed

The following tag can be added or omitted.

No	Tag	Explanation	Note
2	V=Tool center point speed	Specifies the tool center point speed.	Speed: 0.1 mm to 1500.0 mm/s The units can be changed by setting the parameter S2C173. Variable B/B[]/LB/LB[]/I/I[]/LI/LI[]/D/D[]/LD/LD[] can be used. (Units: 0.1 mm/s)

3. VR=Position angular speed

The following tag can be added or omitted.

No	Tag	Explanation	Note
3	VR=Position angular speed	Specifies the position angular speed.	Speed: 0.1 degrees to 180.0 degrees/s Variable B/B[]/LB/LB[]/I/I[]/LI/LI[]/D/D[]/LD/LD[] can be used. (Units: 0.1 deg/s)

4. VE=External axis speed

The following tag can be added or omitted.

No	Tag	Explanation	Note
4	VE=External axis speed	Specifies the external axis speed.	Speed: 0.01% to 100.00% Variable B/B[]/LB/LB[]/I/I[]/LI/LI[]/D/D[]/LD/LD[] can be used.(Units: 0.01 %)

Example

NOP

MOVJ VJ=100.00

MOVL V=138

- • • Moves at the joint speed 100.00%.
- • • Moves at the control point speed 138cm/min.

SPEED VJ=50.00 V=276 VR=30.0

MOVJ

MOVL

- • • Moves at the joint speed 50.00%.
- • • Moves at the control point speed 276 cm/min.
- • • Moves at the position angular speed 60.0 degree/s.

MOVL VR=60.0

END

REFP

Instruction set:

SUBSET	STANDARD	EXPANDED
Available	Available	Available

Function

It is an instruction which has the position data by which a supplementary point of the wall point, etc. for weaving is set.

Construction

The tag which can be used is limited by the type of the job.

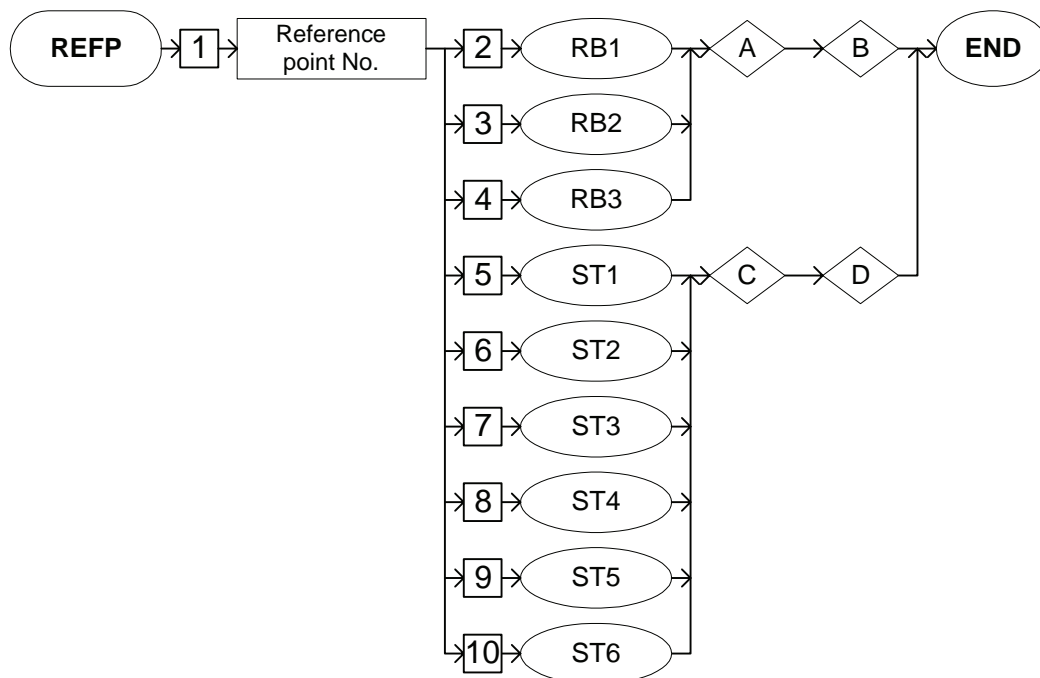

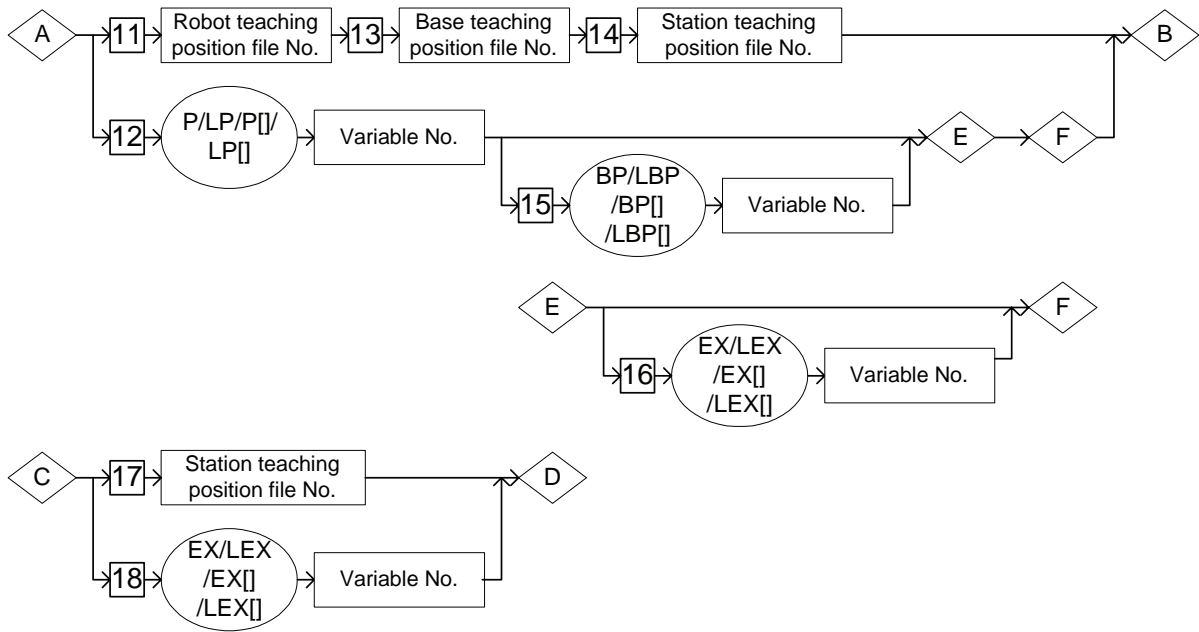

Job Type and Control Group

No.	Job Type	Control Group	Remarks
1	Single	One manipulator (standard)	
2	Single	One manipulator with base axis	
3	Single	One manipulator with station axis	
4	Single	One manipulator with base and station axes	
5	Single	Station axis only	
6	Coordinated	Two manipulators	Optional
7	Coordinated	Two manipulators with base axis	Optional
8	Coordinated	Coordinated job with one manipulator and the station axis (designated as master)	Optional
9	Coordinated	Coordinated job with one manipulator (with base axis) and the station axis (designated as master)	Optional

Availability of Each Tag

No	Tag	Control Group									Note
		1	2	3	4	5	6	7	8	9	
1	Reference point number	●	●	●	●	●	●	●	●	●	
2	RB1	×	×	×	×	×	●	●	●	●	
3	RB2	×	×	×	×	×	●	●	●	●	
4	RB3	×	×	×	×	×	●	●	●	●	
5	ST1	×	×	×	×	×	×	×	●	●	
6	ST2	×	×	×	×	×	×	×	●	●	
7	ST3	×	×	×	×	×	×	×	●	●	
8	ST4	×	×	×	×	×	×	×	●	●	
9	ST5	×	×	×	×	×	×	×	●	●	
10	ST6	×	×	×	×	×	×	×	●	●	
11	Robot teaching position file number	●	●	●	●	×	●	●	●	●	
12	P/LP/P[]/LP[]	●	●	●	●	×	●	●	●	●	
13	Base-axis teaching position file number	×	●	×	●	×	×	●	×	●	
14	Station teaching position file number	×	×	●	●	×	×	×	×	×	
15	BP/LBP/BP[]/LBP[]	×	●	×	●	×	×	●	×	●	
16	EX/LEX/EX[]/LEX[]	×	×	●	●	×	×	×	×	×	
17	Station teaching position file number	×	×	×	×	●	×	×	●	●	
18	EX/LEX/EX[]/LEX[]	×	×	×	×	●	×	×	●	●	

●: Available
 ×: Not available

Explanation

1. Reference Point Number

Add the following tag.

No	Tag	Explanation	Note
1	Reference point number	Specifies the reference point (REFP) number.	Reference points: 1 to 8



Reference points during weaving

Usually it is not necessary to register reference points during the weaving. However, there are cases when it must be registered according to the situation of the workpiece, etc. In this case, the wall direction is defined as REFP1 and the horizontal wall direction is defined as REFP2.

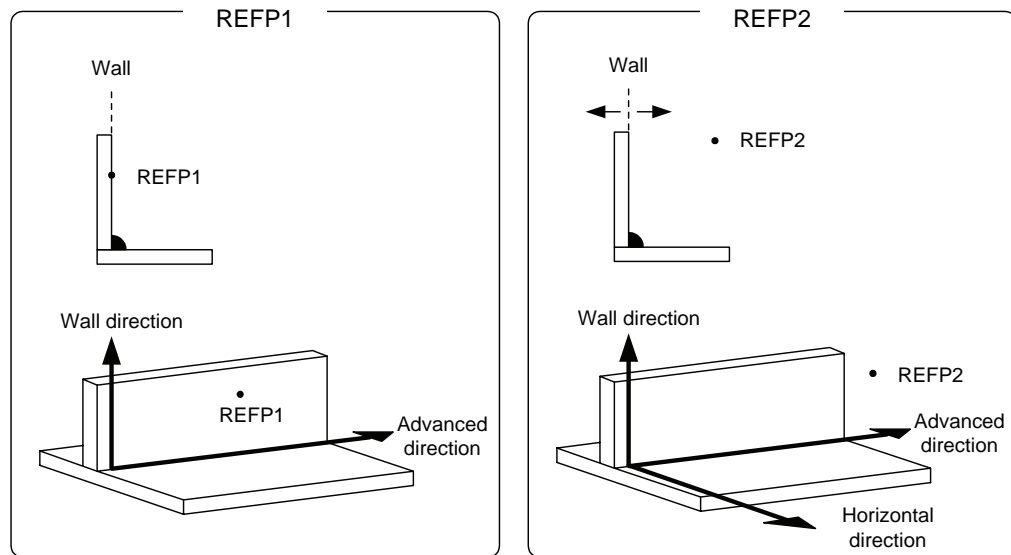

2. RB1/RB2/RB3/ST1/ST2/ST3/ST4/ST5/ST6

Choose one of the tags from the following table.

No	Tag	Explanation	Note
2	RB1	Specifies the reference point of Robot 1.	
3	RB2	Specifies the reference point of Robot 2.	
4	RB3	Specifies the reference point of Robot 3.	
5	ST1	Specifies the reference point of Station 1.	
6	ST2	Specifies the reference point of Station 2.	
7	ST3	Specifies the reference point of Station 3.	
8	ST4	Specifies the reference point of Station 4.	
9	ST5	Specifies the reference point of Station 5.	
10	ST6	Specifies the reference point of Station 6.	

2.4 Move Instruction

3. Robot teaching position file number /P Variable number /LP Variable number /P [Array number] /LP [Array number]

Choose one of the tags from the following table.

No	Tag	Explanation	Note
11	Robot teaching position file number	The position in the reference point where the robot axis is taught is unconditionally written in this file. This teaching position cannot be edited.	On the job display, this tag is not displayed.
12	P Variable number/ LP Variable number/ P [Array number]/ LP [Array number]	Specifies the position variable number of the robot axis. The position data set in the variable of the specified number becomes a reference point.	Variable number: 000 to 127

4. Base Teaching Position File Number

When the robot teaching position file number is selected from the table in part 3 of this Explanation, add the following tag.

No	Tag	Explanation	Note
13	Base teaching position file number	The position in the reference point where the base axis is taught is unconditionally written in this file. This teaching position cannot be edited.	On the job display, this tag is not displayed.

5. Station Teaching Position File Number

When the robot teaching position file number is selected from the table in part 3 of this Explanation, add the following tag.

No	Tag	Explanation	Note
14	Station teaching position file number	The position in the reference point where the station axis is taught is unconditionally written in this file. This teaching position cannot be edited.	On the job display, this tag is not displayed.

6. BP Variable number /LBP Variable number /BP [Array number] /LBP [Array number]

When a P Variable number, LP Variable number, P [Array number], or LP [Array number] is selected from the table in part 3 of this Explanation, the following tag can be added.

No	Tag	Explanation	Note
15	BP Variable number/ LBP Variable number/ BP [Array number]/ LBP [Array number]	Specifies the position variable number of the base axis. The position data set in the variable of the specified number becomes a reference point.	Variable number: 000 to 127

7. EX Variable number /LEX Variable number /EX [Array number] /LEX [Array number]

When a P Variable number, LP Variable number, P [Array number], or LP [Array number] is selected from the table in part 3 of this Explanation, the following tag can be added.

No	Tag	Explanation	Note
16	EX Variable number/ LEX Variable number/ EX [Array number]/ LEX [Array number]	Specifies the position variable number of the station axis. The position data set in the variable of the specified number becomes a reference point.	Variable number: 000 to 127

8. Station teaching position file number/EX Variable number /LEX Variable number /EX [Array number] /LEX [Array number]

Choose one of the tags from the following table.

No	Tag	Explanation	Note
17	Station teaching position file number	The station axis teaching position in each step is written in this file unconditionally when the step is taught. This teaching position cannot be edited.	On the job display, this tag is not displayed.
18	EX Variable number/ LEX Variable number/ EX [Array number]/ LEX [Array number]	Specifies the position variable number of the station axis. The position data set in the variable of a specified number becomes a reference point.	Variable number: 000 to 127

Example

(1) Register REFP1 when the wall direction and the Z direction of the robot axis are different.

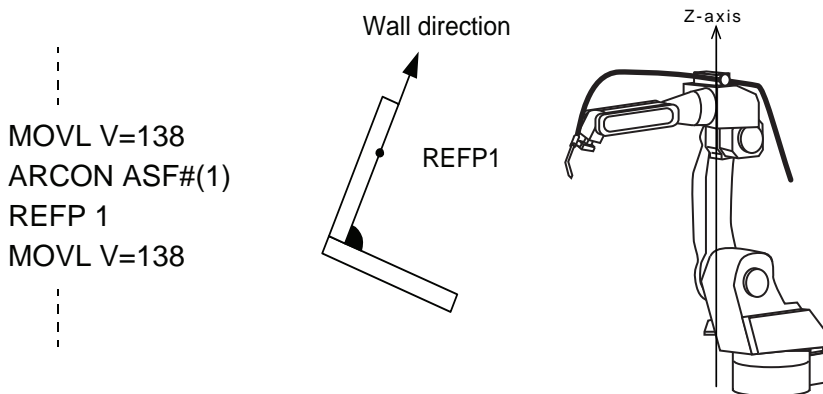

(2) Register REFP2 when the approach point is on the other side of the wall.

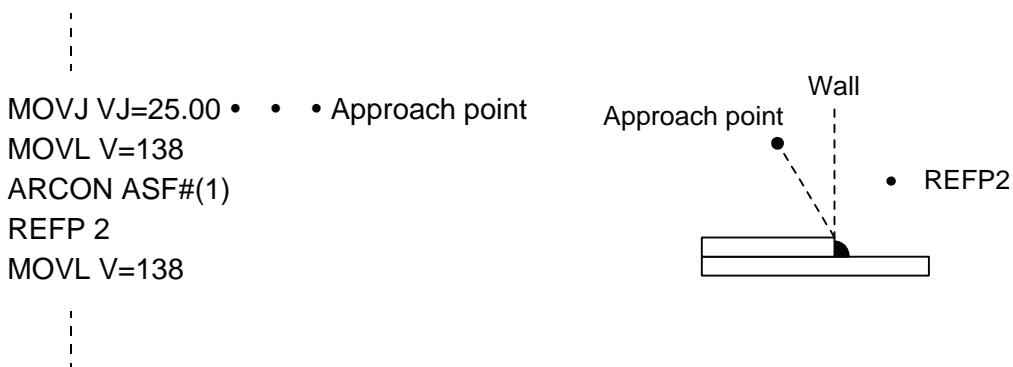

2.5 Shift Instruction

SFTON

Instruction set:

SUBSET	STANDARD	EXPANDED
Available	Available	Available

Function

Begins the parallel shift operation. The amount of the parallel shift is set in a positional variable by the increment value of X, Y, and Z in each coordinate system.

Construction

The tag which can be used is limited by the type of the job.

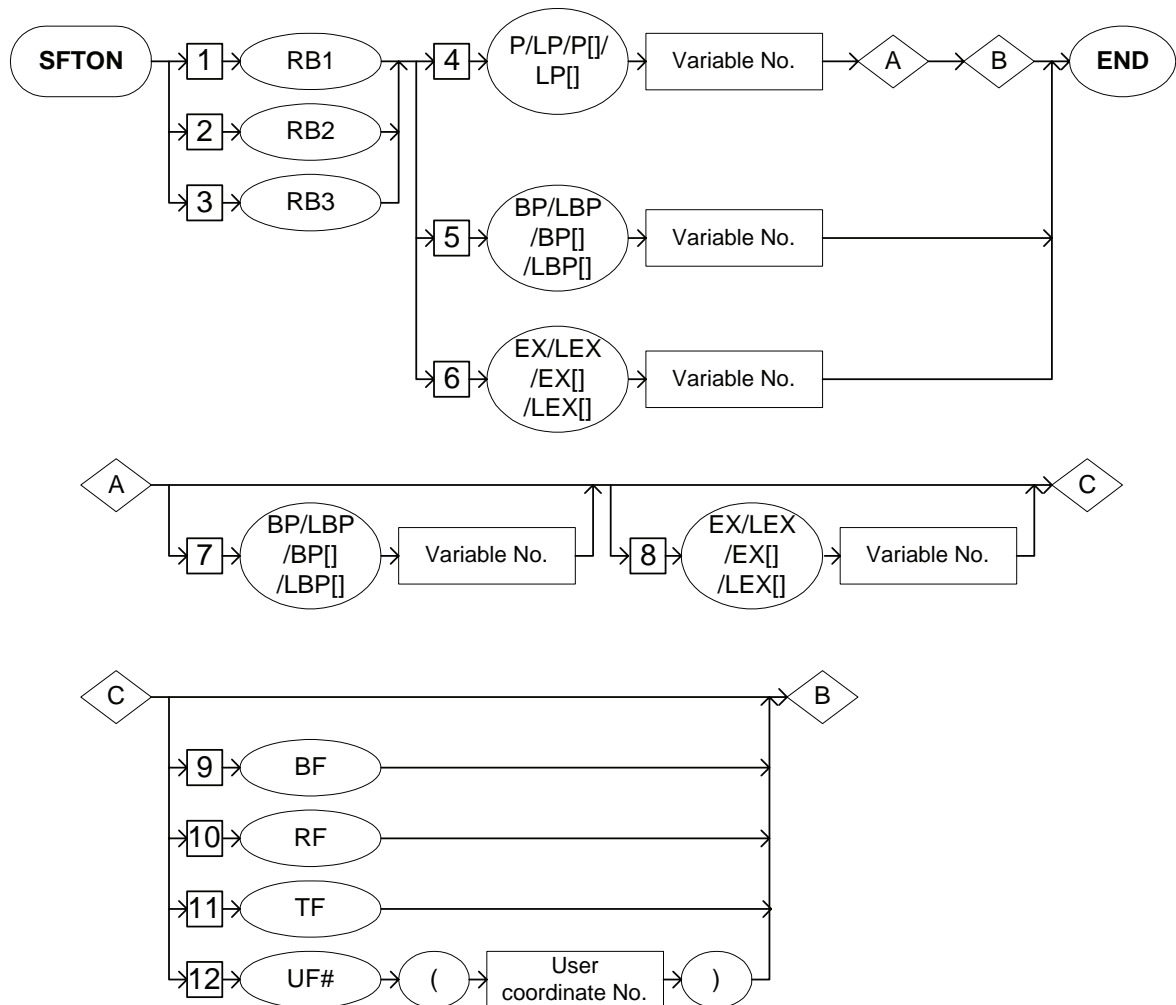

2.5 Shift Instruction

Job Type and Control Group

No.	Job Type	Control Group	Remarks
1	Single	One manipulator (standard)	
2	Single	One manipulator with base axis	
3	Single	One manipulator with station axis	
4	Single	One manipulator with base and station axes	
5	Single	Station axis only	
6	Coordinated	Two manipulators	Optional
7	Coordinated	Two manipulators with base axis	Optional
8	Coordinated	Coordinated job with one manipulator and the station axis (designated as master)	Optional
9	Coordinated	Coordinated job with one manipulator (with base axis) and the station axis (designated as master)	Optional

Availability of Each Tag

No	Tag	Control Group									Note
		1	2	3	4	5	6	7	8	9	
1	RB1	×	×	×	×	×	●	●	●	●	
2	RB2	×	×	×	×	×	●	●	●	●	
3	RB3	×	×	×	×	×	●	●	●	●	
4	P/LP/P[]/LP[]	●	●	●	●	×	●	●	●	●	
5	BP/LBP/BP[]/LBP[]	×	●	×	●	×	×	●	×	●	
6	EX/LEX/EX[]/LEX[]	×	×	●	●	●	×	×	●	●	
7	BP/LBP/BP[]/LBP[]	×	●	×	●	×	×	●	×	●	
8	EX/LEX/EX[]/LEX[]	×	×	●	●	×	×	×	●	●	
9	BF	●	●	●	●	×	●	●	●	●	
10	RF	●	●	●	●	×	●	●	●	●	
11	TF	●	●	●	●	×	●	●	●	●	
12	UF#()	●	●	●	●	×	●	●	●	●	

●: Available
 ×: Not available

Explanation

1. RB1/RB2/RB3

Choose one of the tags from the following table.

No	Tag	Explanation	Note
1	RB1	Specifies Robot 1 for a shift operation.	
2	RB2	Specifies Robot 2 for a shift operation.	
3	RB3	Specifies Robot 3 for a shift operation.	

2. P Variable number /LP Variable number /P [Array number] /LP [Array number] /BP Variable number /LBP Variable number /BP [Array number] /LBP [Array number] /EX Variable number /LEX Variable number /EX [Array number] /LEX [Array number]

Choose one of the tags from the following table.

No	Tag	Explanation	Note
4	P Variable number/ LP Variable number/ P [Array number]/ LP [Array number]	Specifies the position variable number of the robot axis by which the shift value is set. Only the increment value set in the variable of the specified number shifts.	Variable number: 000 to 127
5	BP Variable number/ LBP Variable number/ BP [Array number]/ LBP [Array number]	Specifies the position variable number of the base axis by which the shift value is set. Only the increment value set in the variable of the specified number shifts.	Variable number: 000 to 127
6	EX Variable number/ LEX Variable number/ EX [Array number]/ LEX [Array number]	Specifies the position variable number of the station axis by which the shift value is set. Only the increment value set in the variable of the specified number shifts.	Variable number: 000 to 127

2.5 Shift Instruction

3. BP Variable number /LBP Variable number /BP [Array number] /LBP [Array number]

When a P Variable number, LP Variable number, P [Array number], or LP [Array number] is selected from the table in part 2 of this Explanation, the following tag can be added.

No	Tag	Explanation	Note
7	BP Variable number/ LBP Variable number/ BP [Array number]/ LBP [Array number]	Specifies the position variable number of the base axis by which the shift value is set. Only the increment value set in the variable of the specified number shifts.	Variable number: 000 to 127

4. EX Variable number /LEX Variable number /EX [Array number] /LEX [Array number]

When a P Variable number, LP Variable number, P [Array number], or LP [Array number] is selected from the table in part 2 of this Explanation, the following tag can be added.

No	Tag	Explanation	Note
8	EX Variable number/ LEX Variable number/ EX [Array number]/ LEX [Array number]	Specifies the position variable number of the station axis by which the shift value is set. Only the increment value set in the variable of the specified number shifts.	Variable number: 000 to 127

5. BF/RF/TF/UF# (User coordinate number)

When a P Variable number, LP Variable number, P [Array number], or LP [Array number] is selected from the table in part 2 of this Explanation, choose one of the tags from the following table.

No	Tag	Explanation	Note
9	BF	Specifies the increment value in the base coordinate system.	
10	RF	Specifies the increment value in the robot coordinate system.	
11	TF	Specifies the increment value in the tool coordinate system.	
12	UF#(User coordinate number)	Specifies the increment value in the user coordinate system.	No.1 to 24 Variable B/I/D/LB/LI/LD can be used.

Example

```

NOP
MOVJ VJ=50.0
MOVL V=138
SFTON P000 UF#(1)
MOVL V=138
MOVL V=138
MOVL V=138
SFTOF
MOVL V=138
  
```

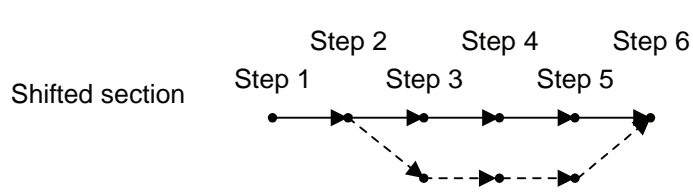

Shift between Step 3 and Step 5 in the user coordinate system.

SFTOF

Instruction set:

SUBSET	STANDARD	EXPANDED
Available	Available	Available

Function

Ends the parallel shift operation.

Construction

The tags to be added are decided according to the type of the job.

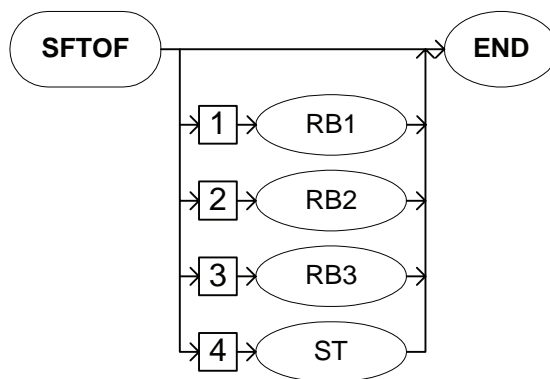

Job Type and Control Group

No.	Job Type	Control group	Remarks
1	Single	One manipulator (standard)	
2	Coordinated	Two manipulators (without station axis)	Optional
3	Coordinated	Two manipulators (with station axis)	Optional

Availability of Each Tag

No	Tag	Control group			Note
		1	2	3	
1	RB1	×	●	●	
2	RB2	×	●	●	
3	RB3	×	●	●	
4	ST	×	×	●	

●: Available
 ×: Not available

Explanation

1. RB1/RB2/RB3/ST

Choose one of the tags from the following table.

No.	Tag	Explanation	Note
1	RB1	Specifies Robot 1 to end a shift operation.	
2	RB2	Specifies Robot 2 to end a shift operation.	
3	RB3	Specifies Robot 3 to end a shift operation.	
4	ST	Specifies the station axis to end a shift operation.	

Example

NOP

MOVJ VJ=50.0

MOVL V=138

SFTON P000 UF#(1)

MOVL V=138

MOVL V=138

MOVL V=138

SFTOF

MOVL V=138

⋮

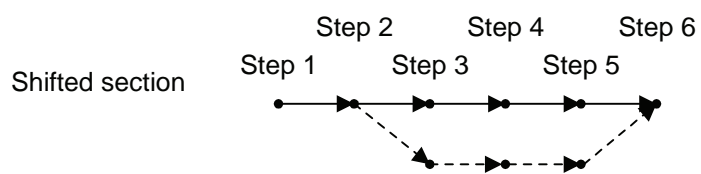

Shift between Step 3 and Step 5 in the user coordinate system.

MSHIFT

Instruction set:

SUBSET	STANDARD	EXPANDED
Not available	Available	Available

Function

Calculates the amount of the shift in the specified coordinate system according to Data 2 and Data 3 and stores the result in Data 1.

Data 2 indicates the reference position to carry out the parallel shift, and Data 3 is the target position (shifted position).

Construction

MSHIFT <Data 1> Coordinate system designation <Data 2> <Data 3>

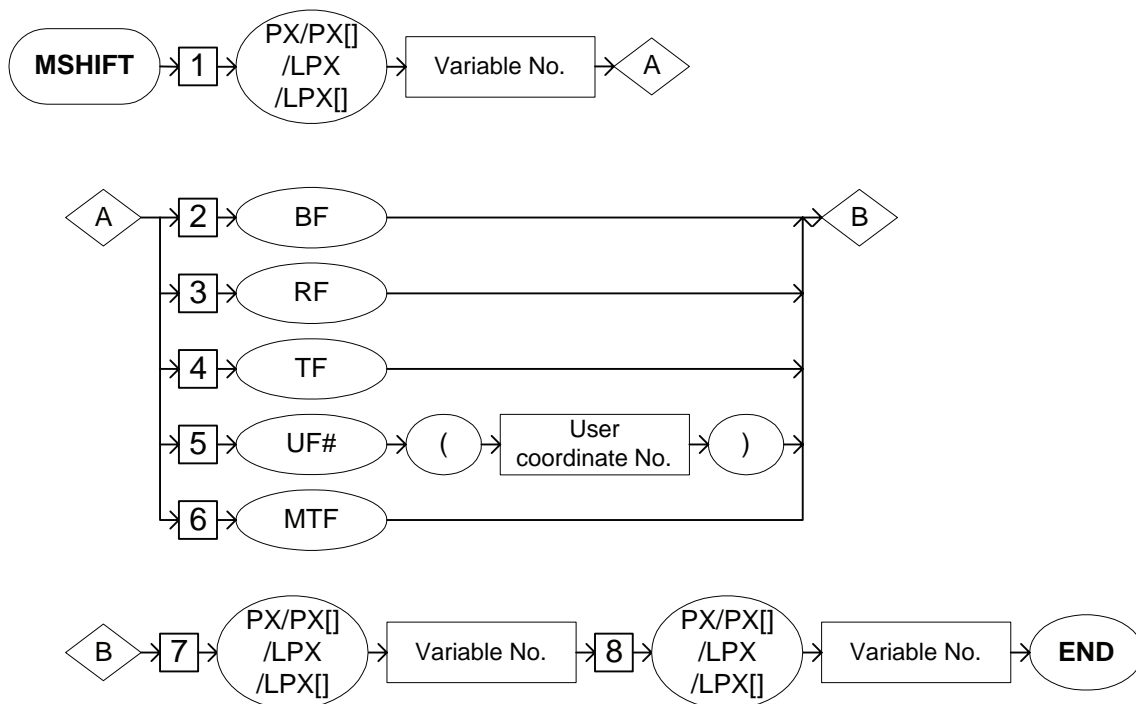

Explanation

1. PX Variable number/LPX Variable number/PX [Array number]/LPX [Array number]

Add the following tag.

No.	Tag	Explanation	Note
1	PX Variable number/ LPX Variable number/ PX [Array number]/ LPX [Array number]	Specifies the number of the expanded position variable to store the calculated shift.	<Data 1>

2. BF/RF/TF/UF# (User coordinate number)/MTF

Choose one of the tags from the following table.

No.	Tag	Explanation	Note
2	BF	Specifies the calculation of the shift amount in the base coordinate system.	
3	RF	Specifies the calculation of the shift amount in the robot coordinate system.	
4	TF	Specifies the calculation of the shift amount in the tool coordinate system.	
5	UF# (User coordinate number)	Specifies the calculation of the shift amount in the user coordinate system.	No.: 1 to 24 Variable B/I/D/LB/LI/LD can be used.
6	MTF	Specifies the calculation of the shift amount in the master tool coordinate system.	Available only with the optional independent/coordinated function.

2.5 Shift Instruction

3. PX Variable number/LPX Variable number/PX [Array number]/LPX [Array number]

Add the following tag.

No.	Tag	Explanation	Note
7	PX Variable number/ LPX Variable number/ PX [Array number]/ LPX [Array number]	Specifies the expanded position type variable number of the reference position to calculate the amount of the shift.	<Data 2>

4. PX Variable number/LPX Variable number/PX [Array number]/LPX [Array number]

Add the following tag.

No.	Tag	Explanation	Note
8	PX Variable number/ LPX Variable number/ PX [Array number]/ LPX [Array number]	Specifies the expanded position type variable number of the target position to calculate the amount of the shift.	<Data 3>

Example

```

NOP
MOVJ VJ=20.00           : Moves to the reference position.
GETS PX000 $PX000      : Sets the current position (the reference position) in the
                        : position variable P000.
MOVJ VJ=20.00           : Moves to the target position.
GETS PX001 $PX000      : Sets the current position (the target position) in the
                        : position variable P001.
MSHIFT PX010 BF PX000 PX001 : Calculates the shift amount and stores it in the position
END                    : variable P010.
```

2.6 Instruction Which Adheres to an Instruction

IF

Instruction set:

SUBSET	STANDARD	EXPANDED
Available	Available	Available

Function

Evaluates the various conditions during operation. This instruction is added after other instructions for processing.

Construction

IF <Comparison element 1> =, <>, <=, >=, <, > <Comparison element 2>

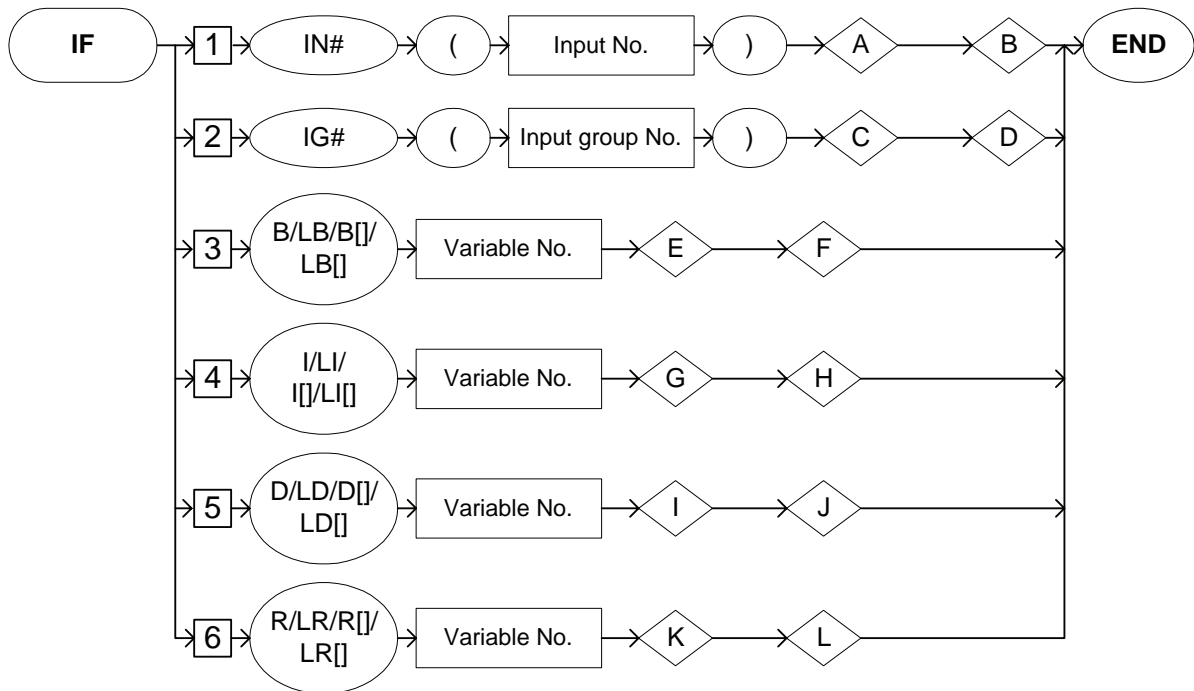

2.6 Instruction Which Adheres to an Instruction

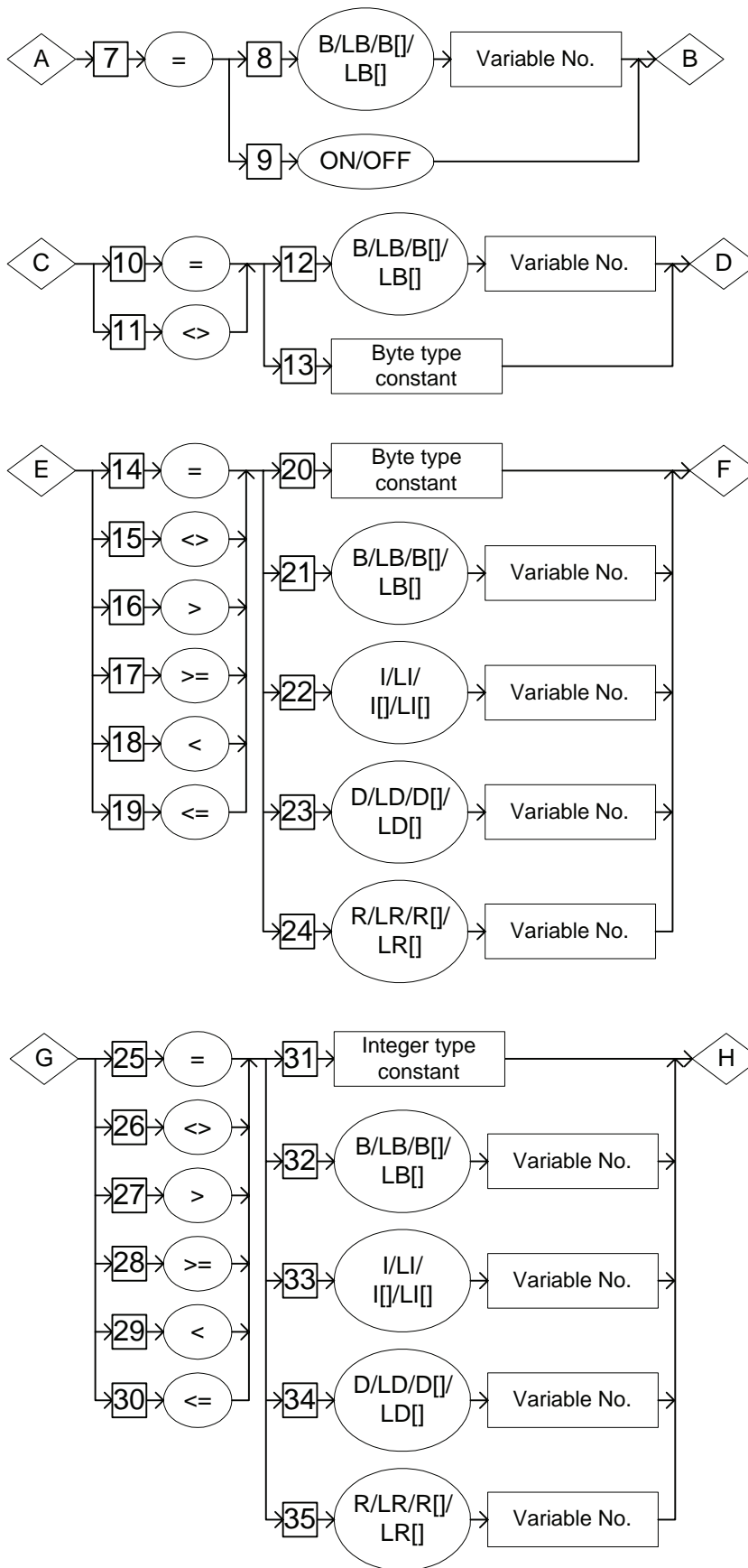

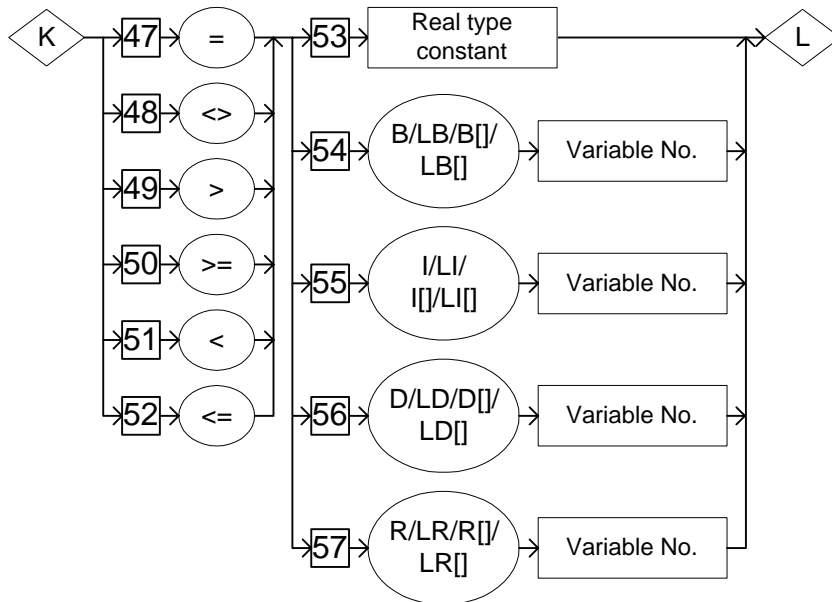
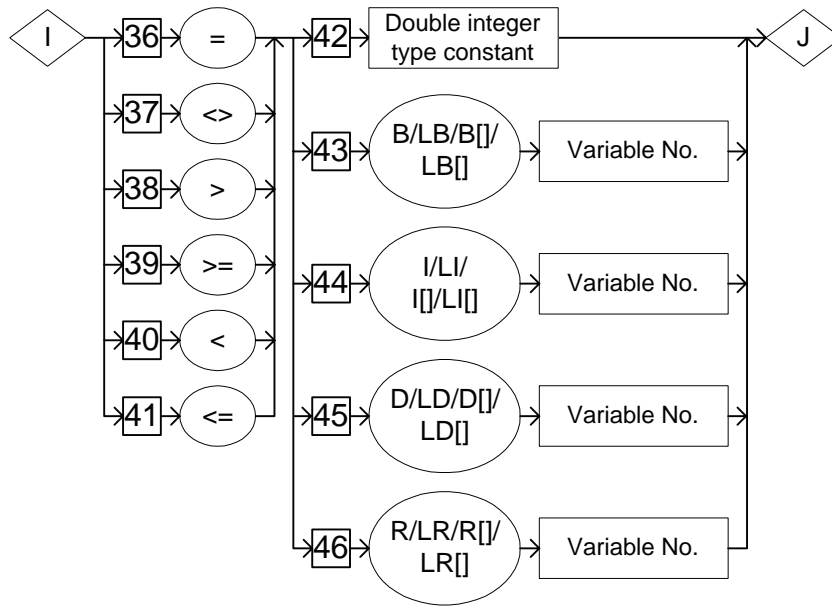

Explanation

1. IN# (Input number) /IG# (Input group number) /B Variable number /LB Variable number /B [Array number] /LB [Array number] /I Variable number /LI Variable number /I [Array number] /LI [Array number] /D Variable number /LD Variable number /D [Array number] /LD [Array number] /R Variable number /LR Variable number /R [Array number] /LR [Array number]

Choose one of the tags from the following table.

No	Tag	Explanation	Note
1	IN# (Input number)	Specifies the number of the general input signal to be compared.	<Comparison element 1> No. : 1 to 1024 Variable B/I/D/LB/LI/LD can be used.
2	IG# (Input group number)	Specifies the number of the general input group signal to be compared.	<Comparison element 1> No. : 1 to 128 Variable B/I/D/LB/LI/LD can be used.
3	B Variable number/ LB Variable number/ B [Array number]/ LB [Array number]	Specifies the number of the byte type variable to be compared.	<Comparison element 1>
4	I Variable number/ LI Variable number/ I [Array number]/ LI [Array number]	Specifies the number of the integer type variable to be compared.	<Comparison element 1>
5	D Variable number/ LD Variable number/ D [Array number]/ LD [Array number]	Specifies the number of the double precision type variable to be compared.	<Comparison element 1>
6	R Variable number/ LR Variable number/ R [Array number]/ LR [Array number]	Specifies the number of the real type variable to be compared.	<Comparison element 1>

2. =

When an IN#(Input number) is selected from the table in part 1 of this Explanation, add the following tag.

No	Tag	Explanation	Note
7	=	It is equal.	

3. B Variable number /LB Variable number /B [Array number] /LB [Array number] /ON /OFF

When an IN#(Input number) is selected from the table in part 1 of this Explanation, choose one of the tags from the following table after the equal sign (=) is added from the table in part 2 of this Explanation.

No	Tag	Explanation	Note
8	B Variable number/ LB Variable number/ B [Array number]/ LB [Array number]	Specifies the byte type variable which becomes a comparison condition.	<Comparison element 2> Least significant bit: 0: OFF 1: ON
9	ON/OFF	The comparison condition is specified as ON or OFF.	<Comparison element 2>

4. =/<>

When an IG#(Input group number) is selected from the table in part 1 of this Explanation, choose one of the tags from the following table.

No	Tag	Explanation	Note
10	=	It is equal.	
11	<>	It is not equal.	

2.6 Instruction Which Adheres to an Instruction

5. B Variable number /LB Variable number /B [Array number] /LB [Array number] /ON /OFF

When an IG#(Input group number) is selected from the table in part 1 of this Explanation, choose one of the tags from the following table after “=” or “<>” are added from the table in part 4 of this Explanation.

No	Tag	Explanation	Note
12	B Variable number/ LB Variable number/ B [Array number]/ LB [Array number]	Specifies the byte type variable which becomes a comparison condition.	<Comparison element 2>
13	Byte type constant	The comparison condition is specified by byte type constant.	<Comparison element 2>

6. =/<>/>/>=/</<=

When a B Variable number, LB Variable number, B [Array number], or LB [Array number] is selected from the table in part 1 of this Explanation, choose one of the tags from the following table.

No	Tag	Explanation	Note
14	=	It is equal.	
15	<>	It is not equal.	
16	>	It is greater than.	
17	>=	It is greater than or equal.	
18	<	It is less than.	
19	<=	It is less than or equal.	

7. Byte type constant /B Variable number /LB Variable number /B [Array number] /LB [Array number] /I Variable number /LI Variable number /I [Array number] /LI [Array number] /D Variable number /LD Variable number /D [Array number] /LD [Array number] /R Variable number /LR Variable number /R [Array number] /LR [Array number]

When a B Variable number, LB Variable number, B [Array number], or LB [Array number] is selected from the table in part 1 of this Explanation, choose one of the tags in the following table after "=", "<>", ">", ">=", "<" or "<=" is selected from the table in part 6 of this Explanation.

No	Tag	Explanation	Note
20	Byte type constant	The comparison condition is specified by the byte type constant.	<Comparison element 2>
21	B Variable number/ LB Variable number/ B [Array number]/ LB [Array number]	Specifies the byte type variable number which becomes a comparison condition.	<Comparison element 2>
22	I Variable number/ LI Variable number/ I [Array number]/ LI [Array number]	Specifies the integer type variable number which becomes a comparison condition.	<Comparison element 2>
23	D Variable number/ LD Variable number/ D [Array number]/ LD [Array number]	Specifies the double precision type variable number which becomes a comparison condition.	<Comparison element 2>
24	R Variable number/ LR Variable number/ R [Array number]/ LR [Array number]	Specifies the real type variable number which becomes a comparison condition.	<Comparison element 2>

2.6 Instruction Which Adheres to an Instruction

8. `=` `<>` `>` `>=` `<` `<=`

When an I Variable number, LI Variable number, I [Array number] or LI [Array number] is selected the table in part 1 of this Explanation, choose one of the tags from the following table.

No	Tag	Explanation	Note
25	=	It is equal.	
26	<>	It is not equal.	
27	>	It is greater than.	
28	>=	It is greater than or equal.	
29	<	It is less than.	
30	<=	It is less than or equal.	

9. Integer type constant /B Variable number /LB Variable number /B [Array number] /LB [Array number] /I Variable number /LI Variable number /I [Array number] /LI [Array number] /D Variable number /LD Variable number /D [Array number] /LD [Array number] /R Variable number /LR Variable number /R [Array number] /LR [Array number]

When an I Variable number, LI Variable number, I [Array number], or LI [Array number] is selected from the table in part 1 of this Explanation, choose one of the tags from the following table after selecting "=", "<>", ">", ">=", "<" or "<=" from the table in part 8 of this Explanation.

No	Tag	Explanation	Note
31	Integer type constant	The comparison condition is specified by the integer type constant.	<Comparison element 2>
32	B Variable number/ LB Variable number/ B [Array number]/ LB [Array number]	Specifies the byte type variable number which becomes a comparison condition.	<Comparison element 2>
33	I Variable number/ LI Variable number/ I [Array number]/ LI [Array number]	Specifies the integer type variable number which becomes a comparison condition.	<Comparison element 2>
34	D Variable number/ LD Variable number/ D [Array number]/ LD [Array number]	Specifies the double precision type variable number which becomes a comparison condition.	<Comparison element 2>
35	R Variable number/ LR Variable number/ R [Array number]/ LR [Array number]	Specifies the real type variable number which becomes a comparison condition.	<Comparison element 2>

2.6 Instruction Which Adheres to an Instruction

10. =/<>/>/>=</<=

When a D Variable number, LD Variable number, D [Array number] or LD [Array number] is selected from the table in part 1 of this Explanation, choose one of the tags from the following table.

No	Tag	Explanation	Note
36	=	It is equal.	
37	<>	It is not equal.	
38	>	It is greater than.	
39	>=	It is greater than or equal.	
40	<	It is less than.	
41	<=	It is less than or equal.	

11. Double precision type constant/ B Variable number /LB Variable number /B [Array number] /LB [Array number] /I Variable number /LI Variable number /I [Array number] /LI [Array number] /D Variable number /LD Variable number /D [Array number] /LD [Array number] /R Variable number /LR Variable number /R [Array number] /LR [Array number]

When a D Variable number, LD Variable number, D [Array number], or LD [Array number] is selected from the table in part 1 of this Explanation, choose one of the tags from the following table after "=", "<>", ">", ">=", "<" or "<=" is selected from the table in part 10 of this Explanation.

No	Tag	Explanation	Note
42	Double precision type constant	The comparison condition is specified by the double precision type constant.	<Comparison element 2>
43	B Variable number/ LB Variable number/ B [Array number]/ LB [Array number]	Specifies the byte type variable number which becomes a comparison condition.	<Comparison element 2>
44	I Variable number/ LI Variable number/ I [Array number]/ LI [Array number]	Specifies the integer type variable number which becomes a comparison condition.	<Comparison element 2>
45	D Variable number/ LD Variable number/ D [Array number]/ LD [Array number]	Specifies the double precision type variable number which becomes a comparison condition.	<Comparison element 2>
46	R Variable number/ LR Variable number/ R [Array number]/ LR [Array number]	Specifies the real type variable number which becomes a comparison condition.	<Comparison element 2>

2.6 Instruction Which Adheres to an Instruction

12. =/ <>/ >/ >= / </ <=

When an R Variable number, LR Variable number, R [Array number] or LR [Array number] is selected from the table in part 1 of this Explanation, choose one of the tags from the following table.

No	Tag	Explanation	Note
47	=	It is equal.	
48	<>	It is not equal.	
49	>	It is greater than.	
50	>=	It is greater than or equal.	
51	<	It is less than.	
52	<=	It is less than or equal.	

13. Real type constant /B Variable number /LB Variable number /B [Array number] /LB [Array number] /I Variable number /LI Variable number /I [Array number] /LI [Array number] /D Variable number /LD Variable number /D [Array number] /LD [Array number] /R Variable number /LR Variable number /R [Array number] /LR [Array number]

When an R Variable number, LR Variable number, R [Array number], or LR [Array number] is selected from the table in part 1 of this Explanation, choose one of the tags from the following table after "=", "<>", ">", ">=", "<" or "<=" is selected from the table in part 12 of this Explanation.

No	Tag	Explanation	Note
53	Real type constant	The comparison condition is specified by the real type constant.	<Comparison element 2>
54	B Variable number/ LB Variable number/ B [Array number]/ LB [Array number]	Specifies the byte type variable number which becomes a comparison condition.	<Comparison element 2>
55	I Variable number/ LI Variable number/ I [Array number]/ LI [Array number]	Specifies the integer type variable number which becomes a comparison condition.	<Comparison element 2>
56	D Variable number/ LD Variable number/ D [Array number]/ LD [Array number]	Specifies the double precision type variable number which becomes a comparison condition.	<Comparison element 2>
57	R Variable number/ LR Variable number/ R [Array number]/ LR [Array number]	Specifies the real type variable number which becomes a comparison condition.	<Comparison element 2>

Example

- (1) SET B000 1
JUMP B000 IF IN#(14)=ON
It jumps to Job 1 if input signal No.14 is turned ON.
- (2) JUMP *2 IF D005<=D006
Jumps to *2 if D005 is below D006.

UNTIL

Instruction set:

SUBSET	STANDARD	EXPANDED
Not available	Available	Available

Function

Evaluates the input conditions during operation. This instruction is added after other instructions for processing.

Construction

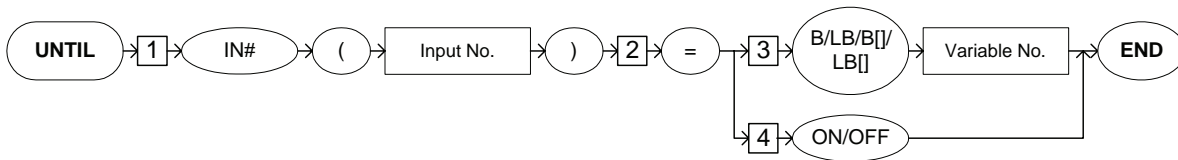

Explanation

1. IN# (Input number)

Add the following tag.

No.	Tag	Explanation	Note
1	IN# (Input number)	Specifies the number of the general-purpose input signal which becomes a input condition.	No.: 1 to 1024 Variable B/I/D/LB/LI/LD can be used.

2. =

Add the following tag.

No.	Tag	Explanation	Note
2	=	It is equal.	

3. B Variable number/LB Variable number/B [Array number]/LB [Array number]/ON/OFF.

Choose one of the tags from the following table after "=" is selected from the table in part 2 of this Explanation.

No.	Tag	Explanation	Note
3	B Variable number/ LB Variable number/ B [Array number]/ LB [Array number]	Specifies the byte type variable to be the condition of execution.	Least significant bit: 0: OFF 1: ON
4	ON/OFF	Specifies the condition as ON or OFF.	

Example

Step 1 MOVJ VJ=100.00

Step 2 MOVJ VJ=50.00 UNTIL IN#(14)=ON

Step 3 MOVJ VJ=25.00

The axis moves toward Step 2 until input signal No. 14 is turned ON. When input signal No. 14 is turned ON, the axis moves toward Step 3.

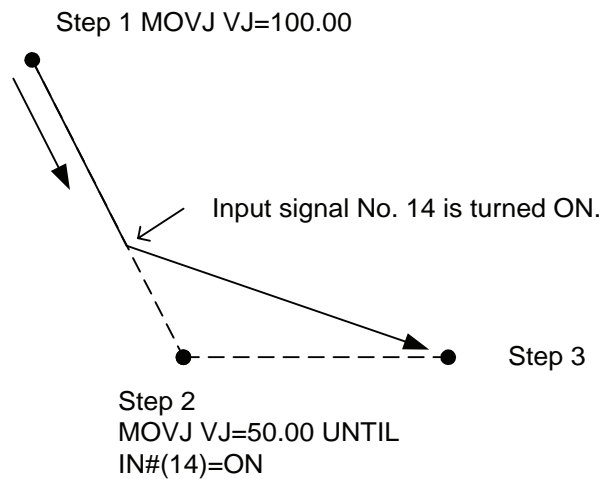

ENWAIT

The ENWAIT instruction can be used only with parameter S2C576.

Instruction set:

SUBSET	STANDARD	EXPANDED	Parameter
Available	Available	Available	S2C576

Function

Carries out, in advance for the specified time, an instruction other than a move instruction on the instruction line next to the move instruction that was added with ENWAIT.

Construction

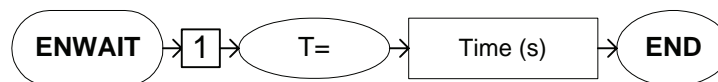

Explanation

1. T=Time

Add the following tag.

No.	Tag	Explanation	Note
1	T=Time	Specifies the time in which the next instruction excluding a move instruction is carried out.	Units: seconds Variable I/LI/I []/LI [] can be used. (Units: 0.01 seconds)

Example

Step 1 MOVL V=136

Step 2 MOVL V=136 ENWAIT T=3.00

DOUT OT#(1) ON

DOUT on the next instruction line is carried out 3 seconds before reaching Step 2.

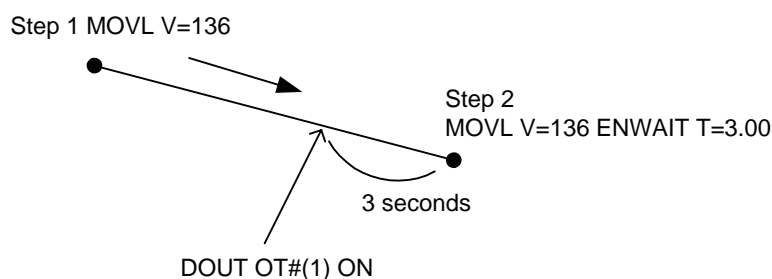

2.7 Arc Welding Instruction

ARCON

For arc welding applications
Instruction set:

SUBSET	STANDARD	EXPANDED
Available	Available	Available

Function

Outputs the welding start command.

Construction

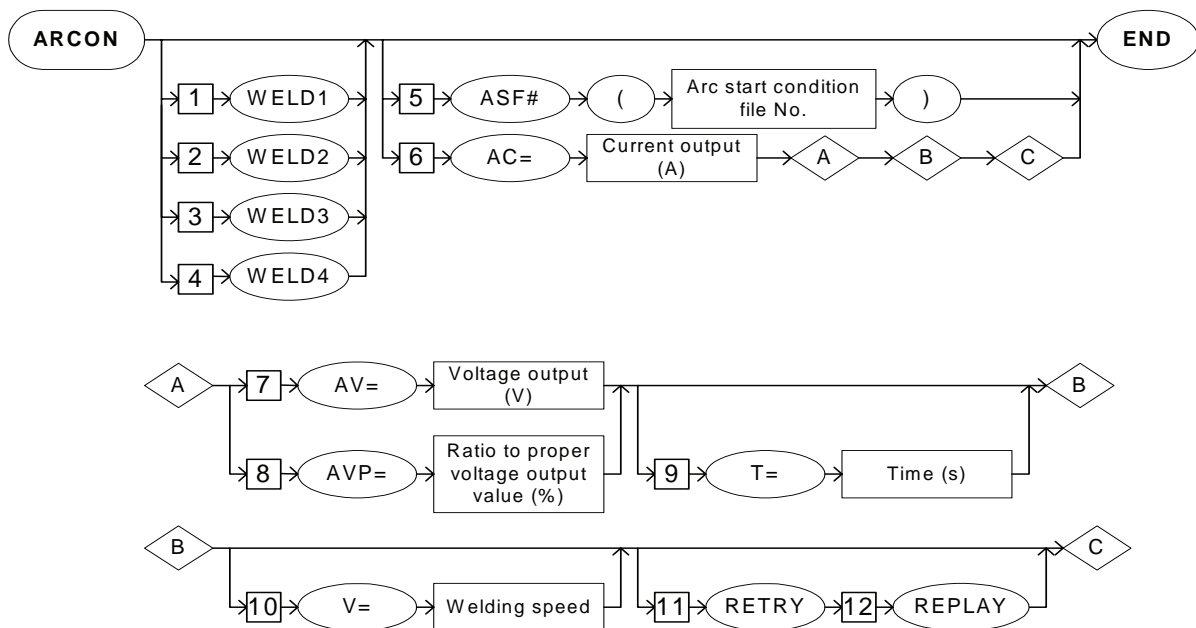

Explanation

1. WELD1/WELD2/WELD3/WELD4

Choose one of the tags from the following table. These tags are valid for a system with multiple applications in which two or more arc welding applications are included. These tags are not displayed when there is only one application.

No	Tag	Explanation	Note
1	WELD1	Specifies Welder 1.	
2	WELD2	Specifies Welder 2.	
3	WELD3	Specifies Welder 3.	
4	WELD4	Specifies Welder 4.	

2. ASF# (Arc start condition file number) /AC=Current output value

Choose one of the tags from the following table.

No	Tag	Explanation	Note
5	ASF#(Arc start condition file number)	Specifies the arc start condition file number. The condition when the welding begins is registered in the arc start condition file.	No: 1 to 48 Variable B/I/D/LB/LI/LD can be used.
6	AC=Current output value	Specifies the output value of the welding current.	Current value: 1 to 999A Variable B/I/D/B[]/I[]/D[]/LB/LI/LD/LB[]/LI[]/LD[] can be used.

3. AV=Voltage output value /AVP=Ratio to proper voltage output value

When AC=Current output value is selected from the table in part 2 of this Explanation, choose one of the tags from the following table.

No	Tag	Explanation	Note
7	AV=Voltage output value	Specifies the output value of the arc voltage. When the welder power supply is 'Individual', the output value of the arc voltage is specified.	Voltage value: 0.1V to 50.0 V Variable B/I/D/B[]/I[]/D[]/LB/LI/LD/LB[]/LI[]/LD[] can be used. (Units: 0.1V)
8	AVP=Ratio to proper voltage output value	Specifies the ratio to the aptitude output value of the arc voltage. When the welder power supply is 'Same', the ratio to the aptitude output value of the arc voltage is specified.	Ratio: 50% to 150% Variable B/I/D/B[]/I[]/D[]/LB/LI/LD/LB[]/LI[]/LD[] can be used.

4. T=Time

When AC=Current output value is selected from the table in part 2 of this Explanation, the following tag can be added or omitted.

No	Tag	Explanation	Note
9	T=Time	Specifies the timer value at the welding start.	Unit: Seconds Variable I/LI/I[]/LI[] can be used. (Units: 0.01 seconds)

5. V=Welding speed

When AC=Current output value is selected from the table in part 2 of this Explanation, the following tag can be added or omitted.

No	Tag	Explanation	Note
10	V=Welding speed	Specifies the speed while welding.	Speed: 0.1 mm to 1500.0 mm/s Setting the parameter S2C101 can change the units. Variable B/B[]/LB/LB[]/I/I[]/LI/LI[]/D/D[]/LD/LD[] can be used. (Units: 0.1 mm/s)

6. RETRY

When AC=Current output value is selected from the table in part 2 of this Explanation, the following tag can be added or omitted.

No	Tag	Explanation	Note
11	RETRY	Specifies the RETRY function. The RETRY function makes it so that the manipulator does not stop and work is not interrupted when an arc generation error occurs.	Refer to the supplement "RETRY function".

7. REPLAY

When RETRY is selected from the table in part 6 of this Explanation, add the following tag.

No	Tag	Explanation	Note
12	REPLAY	Specifies the REPLAY mode. REPLAY mode is one of the operation modes. When the RETRY function is available, the ARCON processing can be done again.	Refer to the supplement "RETRY function".



RETRY function

The RETRY function performs the arc retry automatically with a condition set in the auxiliary condition file, when an arc generation error occurs. When ARCON is processed again, the arc is generated and the manipulator continues working.

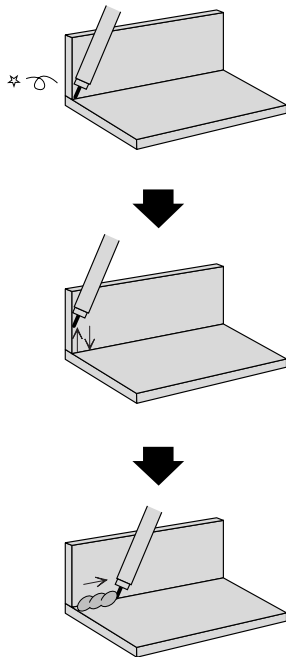

① Arc generation mistake.

② ARCON is processed again.

- REPLAY mode

Returns to the former step, performs retract inching, returns to the start point and tries the arc again.

③ Keeps working when the arc is generated.



For details of the RETRY function, refer to the “Operator’s Manual for Arc Welding”.

Example

(1) ARCON ASF#(1)

Starts welding with the condition set to No.1 in the arc start condition file.

(2) NOP

MOVJ VJ=50.00

• • • Step 1

MOVL V=200

• • • Step 2

MOVL V=220

• • • Step 3

WVON WEV#(2)

• • • Weaving starts

ARCON AC=220 AVP=100 T=0.50

• • • Welding starts

MOVL V=138

• • • Step 4

ARCOF

• • • Welding ends

WVOF

• • • Weaving ends

MOVL V=200

• • • Step 5

MOVJ VJ=50.00

• • • Step 6

END

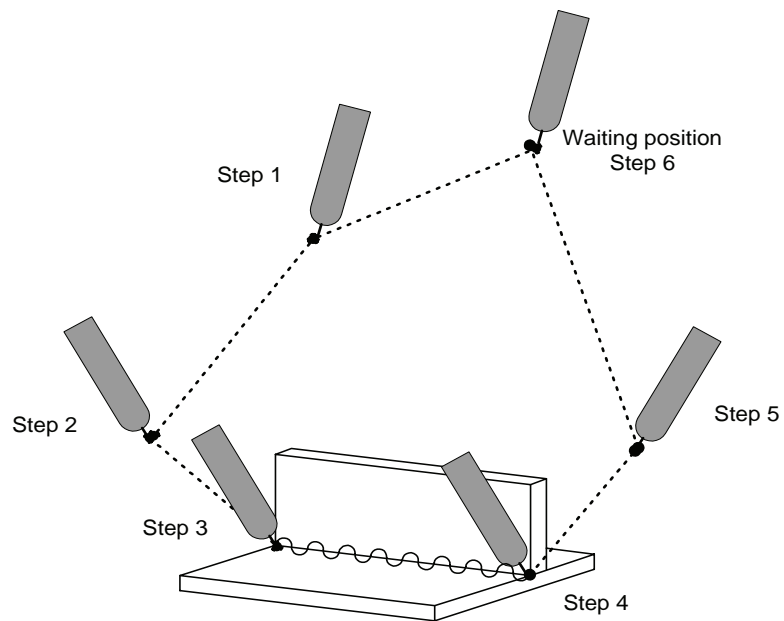

ARCOF

For arc welding applications
Instruction set:

SUBSET	STANDARD	EXPANDED
Available	Available	Available

Function

Outputs welding end command.

Construction

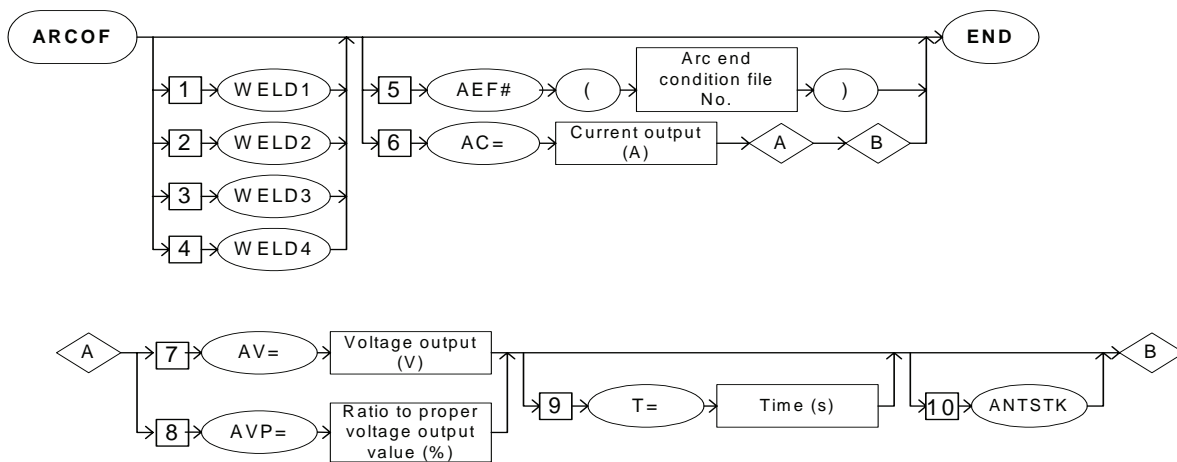

Explanation

1. WELDER1/WELDER2/WELDER3/WELDER4

Choose one of the tags from the following table. These tags are valid for a system with multiple applications in which two or more arc welding applications are included. These tags are not displayed when there is only one application.

No	Tag	Explanation	Note
1	WELDER1	Specifies Welder 1.	
2	WELDER2	Specifies Welder 2.	
3	WELDER3	Specifies Welder 3.	
4	WELDER4	Specifies Welder 4.	

2. AEF# (Arc end condition file number) /AC=Current output value

Choose one of the tags from the following table.

No	Tag	Explanation	Note
5	AEF#(Arc end condition file number)	Specifies the arc end condition file number. The condition when welding has ended is registered in the arc end condition file.	No. : 1 to 12 Variable B/I/D/LB/LI/LD can be used.
6	AC=Current output value	Specifies the output value of the welding current.	Current value: 1 to 999A Variable B/I/D/B[]/I[]/D[]/LB/LI/LD/LB[]/LI[]/LD[] can be used.

3. AV=Voltage output value /AVP=Ratio to proper voltage output value

When AC=Current output value is selected from the table in part 2 of this Explanation, choose one of the tags from the following table.

No	Tag	Explanation	Note
7	AV=Voltage output value	Specifies the output value of the arc voltage. When the welder power supply is 'Individual' the output value of the arc voltage is specified.	Voltage value: 0.1 V to 50.0 V Variable B/I/D/B[]/I[]/D[]/LB/LI/LD/LB[]/LI[]/LD[] can be used. (Units: 0.1 V)
8	AVP=Ratio to proper voltage output value	Specifies the ratio to the aptitude output value of the arc voltage. When the welder power supply is 'Same' the ratio to the aptitude output value of the arc voltage is specified.	Ratio: 50% to 150% Variable B/I/D/B[]/I[]/D[]/LB/LI/LD/LB[]/LI[]/LD[] can be used.

4. T=Time

When AC=Current output value is selected from the table in part 2 of this Explanation, the following tag can be added or omitted.

No	Tag	Explanation	Note
9	T=Time	Specifies the timer value at welding end.	Unit: Seconds Variable I/LI/I[]/LI[] can be used. (Units: 0.01 seconds)

5. ANTSTK

When AC=Current output value is selected from the table in part 2 of this Explanation, the following tag can be added or omitted.

No	Tag	Explanation	Note
10	ANTSTK	Specifies the automatic sticking release function. The automatic wire sticking release function in which the wire sticking is released automatically. It puts out a constant voltage without outputting the wire sticking signal once wire sticking is detected.	Refer to the supplement "Automatic wire sticking release function".



Automatic wire sticking release function

The automatic wire sticking release function in which the wire sticking is released automatically. It puts out a constant voltage without outputting the wire sticking signal once wire sticking is detected. The condition of the frequency etc. of the wire sticking release processing is set in the auxiliary condition file.

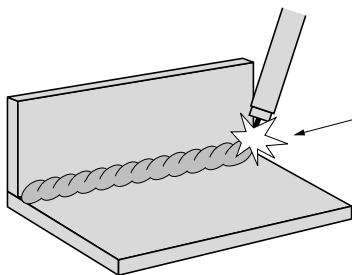

Automatic sticking release

Even if a single attempt has failed, the process is repeated up to the specified maximum repetition count.



For details of the automatic wire sticking release function, refer to the "Operator's Manual for Arc Welding".

Example

(1) ARCOF AEF#(1)

The welding end condition is set in the arc end condition file No.1.

(2) NOP

MOVJ VJ=50.00

• • • Step 1

MOVL V=220

• • • Step 2

MOVL V=200

• • • Step 3

WVON WEV#(2)

• • • Weaving start

ARCON AC=220 AVP=100 T=0.50

• • • Welding start

MOVL V=138

• • • Step 4

ARCOF AC=160 AVP=90 T=0.50

• • • Welding end

WVOF

• • • Weaving end

MOVL V=200

• • • Step 5

MOVJ VJ=50.00

• • • Step 6

END

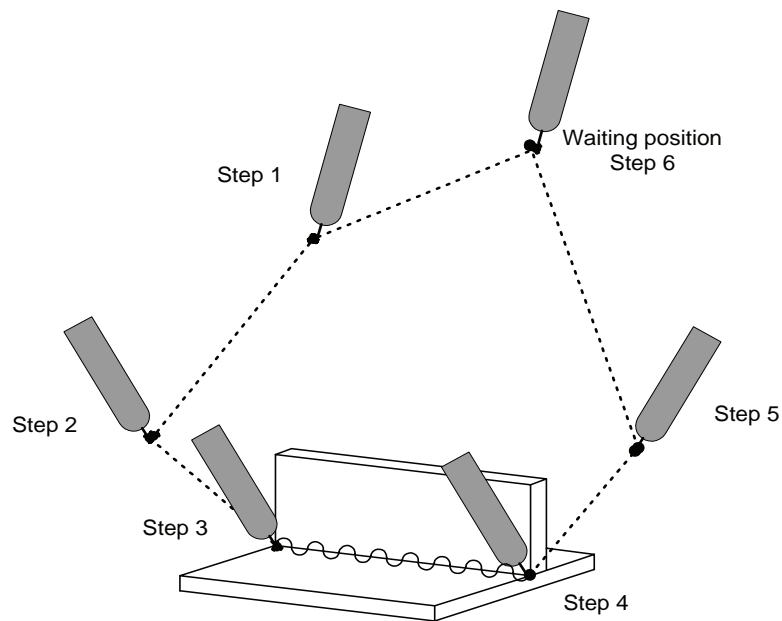

VWELD

For arc welding applications
Instruction set:

SUBSET	STANDARD	EXPANDED
Available	Available	Available

Function

Sets the arc voltage by the voltage command value.

Construction

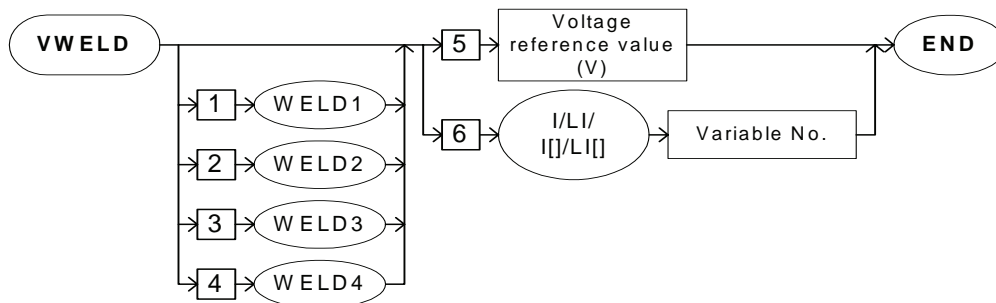

Explanation

1. WELD1 /WELD2/WELD3/WELD4

Choose one of the tags from the following table. These tags are valid for a system with multiple applications in which two or more arc welding applications are included. These tags are not displayed when there is only one application.

No	Tag	Explanation	Note
1	WELD1	Specifies Welder 1.	
2	WELD2	Specifies Welder 2.	
3	WELD3	Specifies Welder 3.	
4	WELD4	Specifies Welder 4.	

2. Voltage command value /I Variable number /LI Variable number /I [Array number] /LI [Array number]

Choose one of the tags from the following table.

No	Tag	Explanation	Note
5	Voltage command value	Specifies the command value of the arc voltage. This is a command value of the voltage which is transmitted from the controller to the welder to output the welding voltage from the welder. The relation between the command welding voltage and the output value is different depending on the model of the welder.	Command value: -14.00 V to +14.00 V Variable I/LI/I[]/LI[] can be used. (Units: 0.01 V)
6	I Variable number/ LI Variable number/ I [Array number]/ LI [Array number]	Specifies the integer type variable number by which the command value of the arc voltage is set.	



For details of the output characteristics of the welder, refer to the "Operator's Manual for Arc Welding".

Example

- (1) VWELD 6.0
The command value of the arc voltage is set to 6.0V.
- (2) SET I000 500
VWELD I000
Set to 5.0V to which the command value of the arc voltage is set with I000.

AWELD

For arc welding applications
Instruction set:

SUBSET	STANDARD	EXPANDED
Available	Available	Available

Function

Sets the welding current by the current command position.

Construction

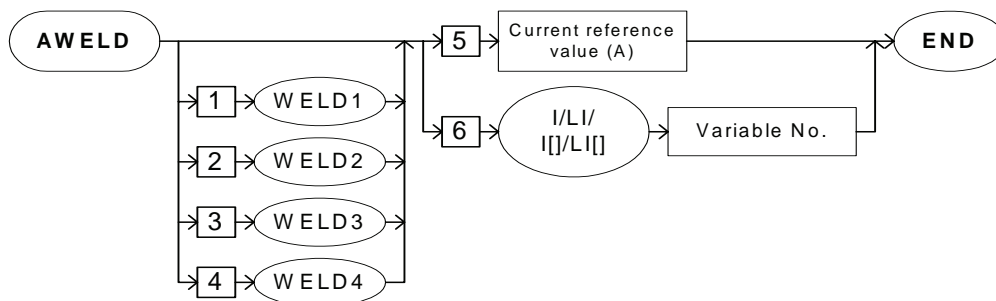

Explanation

1. WELD1/WELD2/WELD3/WELD4

Choose one of the tags from the following table. These tags are valid for a system with multiple applications in which two or more arc welding applications are included. These tags are not displayed when there is only one application.

No	Tag	Explanation	Note
1	WELD1	Specifies Welder 1.	
2	WELD2	Specifies Welder 2.	
3	WELD3	Specifies Welder 3.	
4	WELD4	Specifies Welder 4.	

2. Current command value /I Variable number /LI Variable number /I [Array number] /LI [Array number]

Choose one of the tags from the following table.

No	Tag	Explanation	Note
5	Current command value	Specifies the command value of the welding current. This is a command value of the current which is transmitted from the controller to the welder to output the welding current from the welder. The relation between the command welding current and the output value is different depending on the model of the welder.	Command value: -14.00 V to +14.00 V Variable I/LI/I[]/LI[] can be used. (Units: 0.01 V)
6	I Variable number/ LI Variable number/ I [Array number]/ LI [Array number]	Specifies the integer type variable number by which the command value of the welding current is set.	



For details of the output characteristics of the welder, refer to the "Operator's Manual for Arc Welding".

Example

(1) AWELD 6.0

The command value of the welding current is set to 6.0V.

(2) SET I000 500

AWELD I000

Set to 5.0V to which the command value of the welding current is set with I000.

ARCSET

For arc welding applications
Instruction set:

SUBSET	STANDARD	EXPANDED
Available	Available	Available

Function

Sets and changes each welding condition individually.

Construction

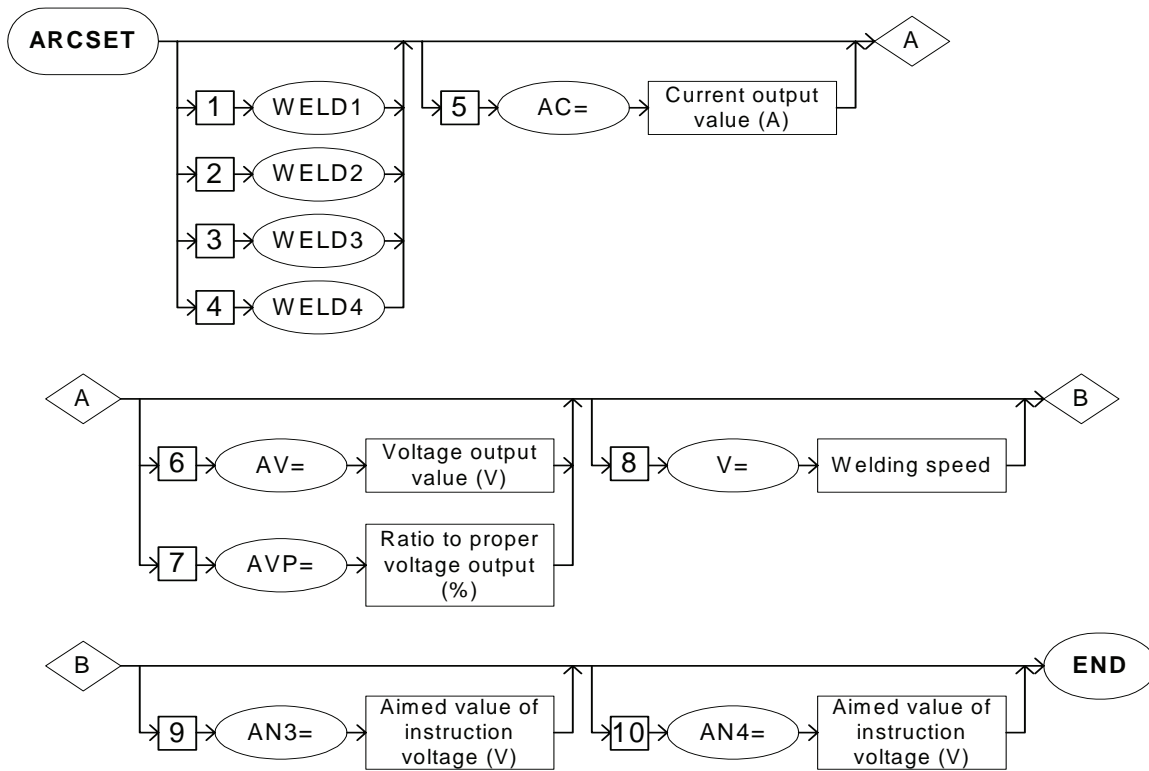

Explanation

1. WELD1/WELD2/WELD3/WELD4

Choose one of the tags from the following table. These tags are valid for a system with multiple applications in which two or more arc welding applications are included. These tags are not displayed when there is only one application.

No.	Tag	Explanation	Note
1	WELD1	Specifies Welder 1.	
2	WELD2	Specifies Welder 2.	
3	WELD3	Specifies Welder 3.	
4	WELD4	Specifies Welder 4.	

2. AC=Current output value

The following tag can be added or omitted.

No.	Tag	Explanation	Note
5	AC=Current output value	Specifies the output value of the welding current.	Current value: 1 to 999 A Variable B/I/D/B[]/I[]/ D[]/LB/LI/LD/LB[]/ LI[]/LD[] can be used.

3. AV=Voltage output value/AVP=Ratio to proper voltage output value

Choose one of the tags from the following table.

No.	Tag	Explanation	Note
6	AV=Voltage output value	Specifies the output value of the arc voltage. When the welder power supply is 'Individual', the output value of the arc voltage is specified.	Voltage value: 0.1V to 50.0 V Variable B/I/D/B[]/I[]/ D[]/LB/LI/LD/LB[]/ LI[]/LD[] can be used. (Units: 0.1V)
7	AVP=Ratio to proper voltage output value	Specifies the ratio to the aptitude output value of the arc voltage. When the welder power supply is 'Same', the ratio to the aptitude output value of the arc voltage is specified.	Ratio: 50% to 150% Variable B/I/D/B[]/I[]/ D[]/LB/LI/LD/LB[]/ LI[]/LD[] can be used.

2.7 Arc Welding Instruction

4. V=Welding speed

The following tag can be added or omitted.

No.	Tag	Explanation	Note
8	V=Welding speed	Specifies the speed while welding.	Speed: 0.1 mm to 1500.0 mm/s. Setting the parameter S2C101 can change the units. Variable B/I/D/B[I]/D[I]/LB/LI/LD/LB[I]/LI[I]/LD[I] can be used. (Units: 0.1 mm/s)

5. AN3=Aimed value of instruction voltage

The following tag can be added or omitted.

No.	Tag	Explanation	Note
9	AN3=Aimed value of instruction voltage	Specifies the aimed value of the instruction voltage to analog output 3.	Aimed value: -14.00 V to +14.00 V Variable I/LI/I[I]/LI[I] can be used. (Units: 0.01 V)

6. AN4=Aimed value of instruction voltage

The following tag can be added or omitted.

No.	Tag	Explanation	Note
10	AN4=Aimed value of instruction voltage	Specifies the aimed value of the instruction voltage to analog output 4.	Aimed value: -14.00 V to +14.00 V Variable I/LI/I[I]/LI[I] can be used. (Units: 0.01 V)

Example

NOP	
MOVJ VJ=50.00	• • • Step 1
MOVJ VJ=80.00	• • • Step 2 (Arc start position)
ARCON AC=200 AVP=100 T=0.30	• • • Arc starts
MOVL V=50	• • • Step 3
MOVL V=50	• • • Step 4
ARCSET AC=250	• • • Changes the welding condition (AC=200 → AC=250)
MOVL V=65	
ARCOF	• • • Step 5
MOVJ VJ=50.00	• • • Arc ends
MOVJ VJ=100.00	• • • Step 6
END	• • • Step 7

WVON

For arc, general-purpose, and laser welding applications
 Instruction set:

SUBSET	STANDARD	EXPANDED
Available	Available	Available

Function

Starts weaving operation.

Construction

The tags to be added differ depending on the control group in the job.

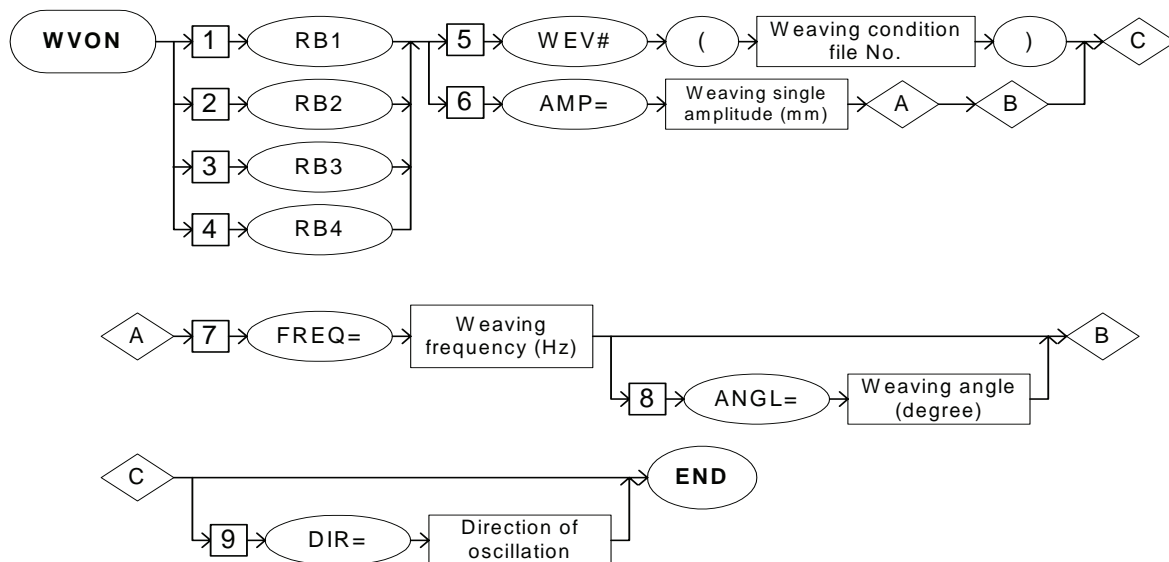

Job Type and Control Group

No.	Job Type	Control Group	Remarks
1	Single	One manipulator (standard)	
2	Coordinated	Two manipulators	Optional

Availability of Each Tag

No	Tag	Control Group		Note
		1	2	
1	RB1	×	●	
2	RB2	×	●	
3	RB3	×	●	
4	WEV#()	●	●	
5	AMP=	●	●	
6	FREQ=	●	●	
7	ANGL=	●	●	
8	DIR=	●	●	

●: Available
 ×: Not available

Explanation

1. RB1/RB2/RB3/RB4

Choose one of the tags from the following table.

No	Tag	Explanation	Note
1	RB1	Specifies Robot 1 for weaving.	
2	RB2	Specifies Robot 2 for weaving.	
3	RB3	Specifies Robot 3 for weaving.	
4	RB4	Specifies Robot 4 for weaving.	

2. WEV# (Weaving condition file number)/AMP=Weaving single amplitude

Choose one of the tags from the following table.

No	Tag	Explanation	Note
5	WEV#(Weaving condition file number)	Specifies the weaving condition file number. The condition when the weaving operates is registered in the weaving condition file.	No. : 1 to 16 Variable B/I/D/LB/LI/LD can be used.
6	AMP=Weaving signal amplitude	Specifies the amplitude of oscillation for weaving.	Single amplitude: 0.1 mm to 99.9 mm Variable B/B[]/LB/LB[]/I/I[]/LI/LI[]/D/D[]/LD/LD[] can be used. (Units: 0.1 mm)

3. FREQ=Weaving frequency

When AMP=Weaving single amplitude is selected from the table in part 2 of this Explanation, add the following tag.

No.	Tag	Explanation	Note
7	FREQ=Weaving frequency	Specifies the weaving frequency.	Frequency: 1.0 Hz to 5.0 Hz Variable B/I/D/B[]/I[]/D[]/LB/LI/LD/LB[]/LI[]/LD[] can be used. (Units: 0.1 Hz)

4. ANGL=Weaving angle

When AMP=Weaving single amplitude is selected from the table in part 2 of this Explanation, the following tag can be added or omitted after the tag FREQ=Weaving frequency is selected from the table in part 3 of this Explanation.

No.	Tag	Explanation	Note
8	ANGL=Weaving angle	Specifies the weaving angle.	Angle: 0.1 deg. to 180.0 deg. Variable B/I/D/B[]/I[]/D[]/LB/LI/LD/LB[]/LI[]/LD[] can be used. (Units: 0.1 deg.)

5. DIR=Direction of oscillation

The following tag can be added or omitted.

No.	Tag	Explanation	Note
9	DIR=Direction of oscillation	Specifies the direction of oscillation. Refer to the supplement "Weaving conditions".	Direction: 0 or 1 0: Forward 1: Reversed Variable B/I/D/B[]/I[]/ D[]/LB/LI/LD/LB[]/ LI[]/LD[] can be used.



Wearing conditions

- Weaving single amplitude
Set the amplitude of oscillation.

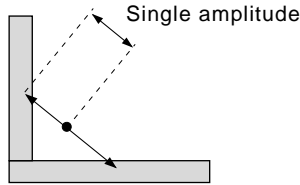

- Weaving angle
Set the angle of oscillation.

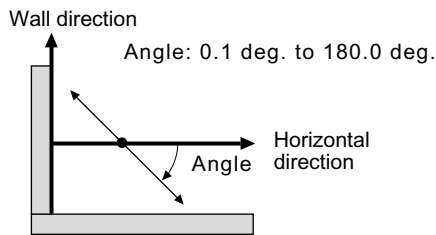

Weaving mode: Single oscillation

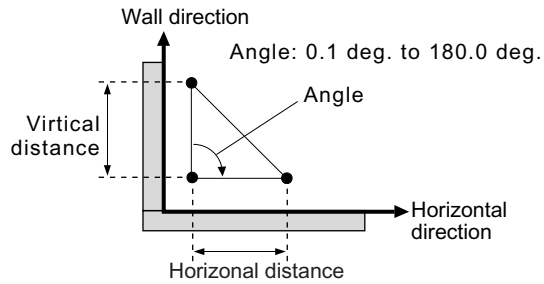

Weaving mode: Triangular or L-shape oscillation

- Direction of oscillation
The directions, "forward" and "reversed", are defined as follows. Set "0 (forward)" or "1 (reversed)" for the direction of oscillation.

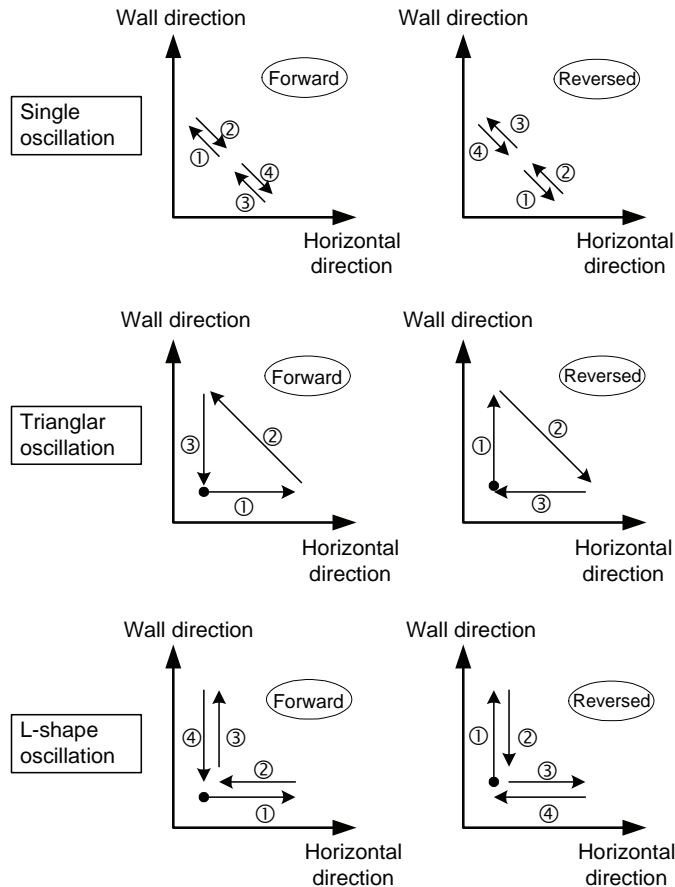



For details of the weaving condition file number, refer to the "Operator's Manual for the Arc Welding".

Example

(1) WVON WEV#(1) DIR=1

Weaving starts with the conditions specified in the weaving condition file.

(2) NOP

MOVJ VJ=50.00

• • • Step 1

MOVL V=220

• • • Step 2

MOVL V=200

• • • Step 3

WVON AMP=5.0 FREQ=3.0 ANGL=40.0

• • • Weaving starts

ARCON AC=220 AVP=100 T=0.5

• • • Welding starts

MOVL V=138

• • • Step 4

ARCOF AC=160 AVP=90 T=0.50

• • • Welding ends

WVOF

• • • Weaving ends

MOVL V=200

• • • Step 5

MOVJ VJ=50.00

• • • Step 6

END

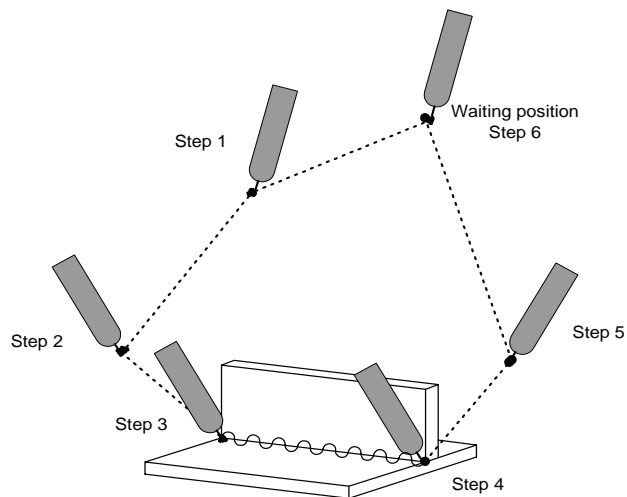

WVOF

For arc, general-purpose, and laser welding applications
 Instruction set:

SUBSET	STANDARD	EXPANDED
Available	Available	Available

Function

Ends weaving operation.

Construction

The tags to be added differ depending on the control group in the job.

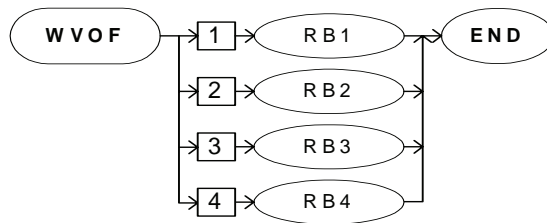

Job Type and Control Group

No.	Job Type	Control Group	Remarks
1	Single	One manipulator (standard)	
2	Coordinated	Two manipulators	Optional

Availability of Each Tag

No	Tag	Controlled group		Note
		1	2	
1	RB1	×	●	
2	RB2	×	●	
3	RB3	×	●	
4	RB4	×	●	

●: Available
 ×: Not available

Explanation

1. RB1/RB2/RB3/RB4

Choose one of the tags from the following table.

No	Tag	Explanation	Note
1	RB1	Specifies Robot 1 to end weaving.	
2	RB2	Specifies Robot 2 to end weaving.	
3	RB3	Specifies Robot 3 to end weaving.	
4	RB4	Specifies Robot 4 to end weaving.	

Example

NOP

MOVJ VJ=50.00

MOVL V=220

MOVL V=200

WVON WEV#(2)

ARCON AC=220 AVP=100 T=0.50

MOVL V=138

ARCOF AC=160 AVP=90 T=0.50

WVOF

MOVL V=200

MOVJ VJ=50.00

END

- • • Step 1
- • • Step 2
- • • Step 3
- • • Weaving starts
- • • Welding starts
- • • Step 4
- • • Welding ends
- • • Weaving ends
- • • Step 5
- • • Step 6

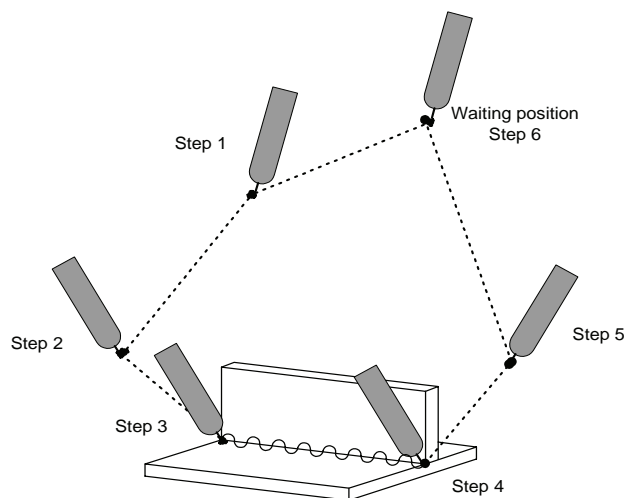

ARCCTS

For arc welding applications
Instruction set:

SUBSET	STANDARD	EXPANDED
Available	Available	Available

Function

Controls the welding current and the voltage in the specified starting section.
This function is used with the move instruction. The current and the voltage are changed while the robot is moving. The aimed value and section have to be set. The section is specified as a distance from the moving start point. If it is not specified, it is regarded as the entire section of the move instruction.

Construction

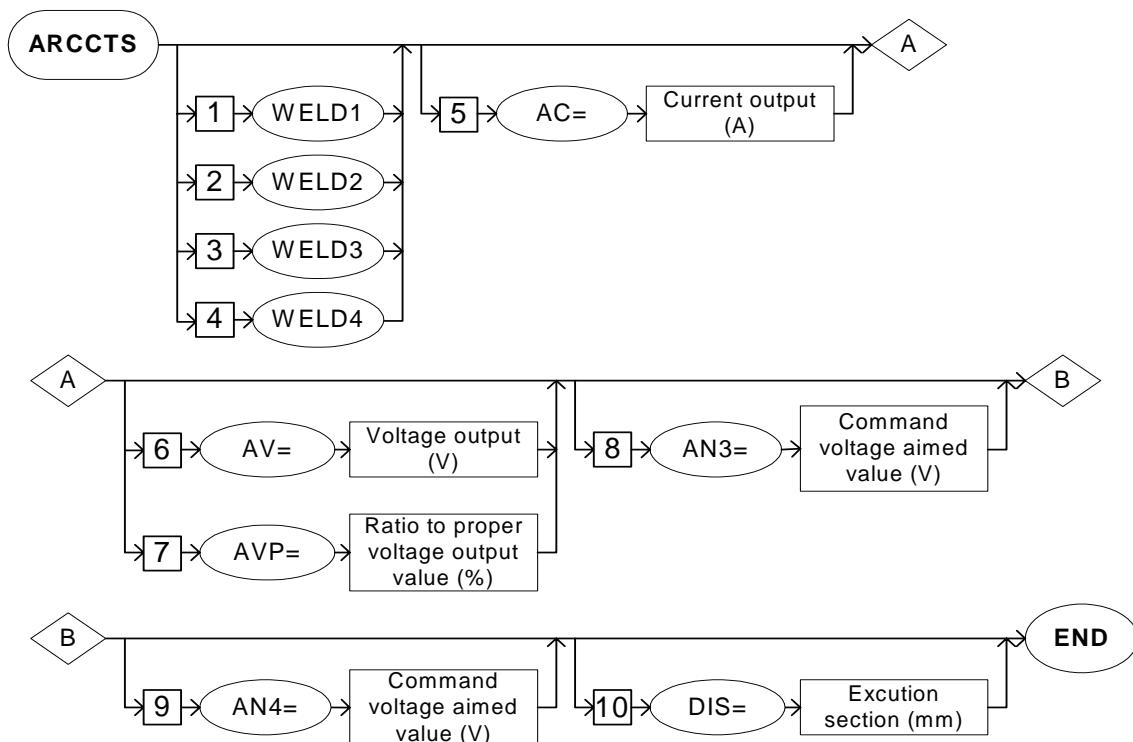

Explanation

1. WELD1/WELD2/WELD3/WELD4

Choose one of the tags from the following table. These tags are valid for a system with multiple applications in which two or more arc welding applications are included. These tags are not displayed when there is only one application.

No	Tag	Explanation	Note
1	WELD1	Specifies Welder 1.	
2	WELD2	Specifies Welder 2.	
3	WELD3	Specifies Welder 3	
4	WELD4	Specifies Welder 4	

2. AC=Current output value

The following tag can be added or omitted.

No	Tag	Explanation	Note
5	AC=Current output value	Specifies the aimed value of the welding current.	Current value: 1 to 999A Variable B/I/D/B[]/I[]/D[]/LB/LI/LD/LB[]/LI[]/LD[] can be used.

3. AV=Voltage output value /AVP=Ratio to proper voltage output value

Choose one of the tags from following table.

No	Tag	Explanation	Note
6	AV=Voltage output value	Specifies the aimed value of the welding voltage.	Voltage value: 0.1 V to 50.0 V Variable B/I/D/B[]/I[]/D[]/LB/LI/LD/LB[]/LI[]/LD[] can be used. (Units: 0.1 V)
7	AVP=Ratio to proper voltage output value	Specifies the aimed value for the welding voltage in the ratio to the proper voltage output value.	Ratio: 50% to 150% Variable B/I/D/B[]/I[]/D[]/LB/LI/LD/LB[]/LI[]/LD[] can be used.

2.7 Arc Welding Instruction

4. AN3=Aimed value of instruction voltage

The following tag can be added or omitted.

No	Tag	Explanation	Note
8	AN3=Aimed value of instruction voltage	Specifies the aimed value of the instruction voltage to analog output 3.	Aimed value: -14.00 V to +14.00 V Variable I/I[]/LI/LI[] can be used. (Units: 0.01 V)

5. AN4=Aimed value of instruction voltage

The following tag can be added or omitted.

No	Tag	Explanation	Note
9	AN4=Aimed value of instruction voltage	Specifies the aimed value of the instruction voltage to analog output 4.	Aimed value: -14.00 V to +14.00 V Variable I/I[]/LI/LI[] can be used. (Units: 0.01 V)

6. DIS=Execution section

The following tag can be added or omitted.

No	Tag	Explanation	Note
10	DIS=Execution section	Specifies the execution section where the current and the voltage are changed. The execution section is set by the distance from the moving start point. If the section is not specified, all the section of the move instruction is regarded as the execution section.	Section: 0.1 mm to 6553.5 mm Variable B/I/D/B[]/I[]/D[]/LB/LI/LD/LB[]/LI[]/LD[] can be used. (Units: 0.1 mm)



Slope up/down function

The slope up/down function allows for the current and the voltage value etc., during welding to be gradually changed.

This function is used when the base metal is a board, or when the object is an aluminum which has high heat conductivity.

In this function, the ARCCTS and the ARCCTE instruction are used.

For details of the slope up/down function, refer to the "Operator's Manual for the Arc Welding".

Example

(1) ARCCTS AC=150 AV=16.0 DIS=100.0

MOVL V=80

To make the welding current =150A and arc voltage =16V, the current and the voltage are changed in the section of 100mm from the move start point.

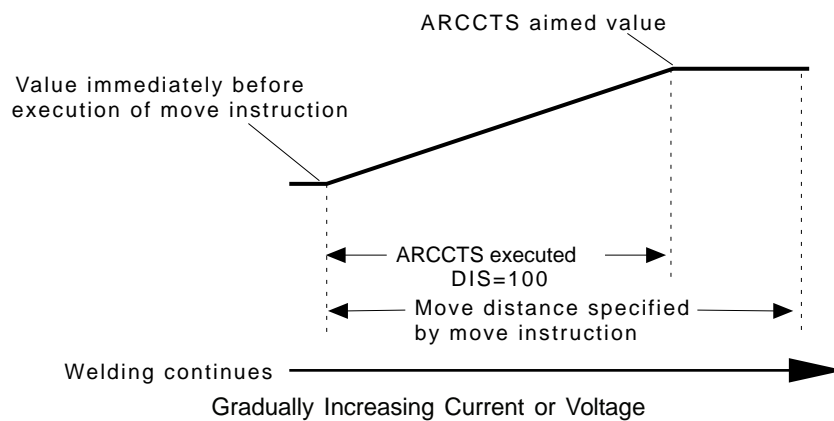
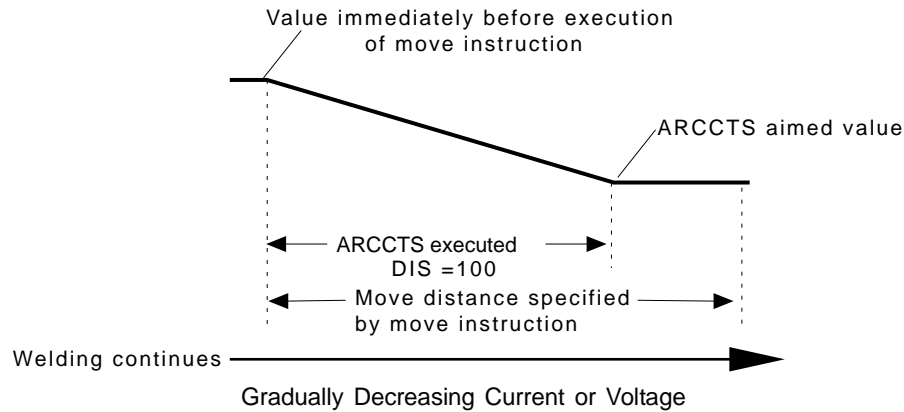

(2) ARCCTS AC=150 AV=16.0 AN3=7.50 AN4=6.50 DIS=100.0

To make the welding current =150A, arc voltage =16V, aimed value =7.5V of the instruction voltage to analog output 3, and aimed value =6.5V of the instruction voltage to analog output 4, the current and the voltage are changed in the section of 100mm from the move start point.

ARCCTE

For arc welding applications
Instruction set:

SUBSET	STANDARD	EXPANDED
Available	Available	Available

Function

Controls the welding current and the voltage in the specified end section.
This function is used with the move instruction and modifies the current and the voltage while the manipulator is moving. The aimed value and the section are set. The section is specified as a distance from the moving end point. If it is not specified, it is regarded as the entire section of the move instruction.

Construction

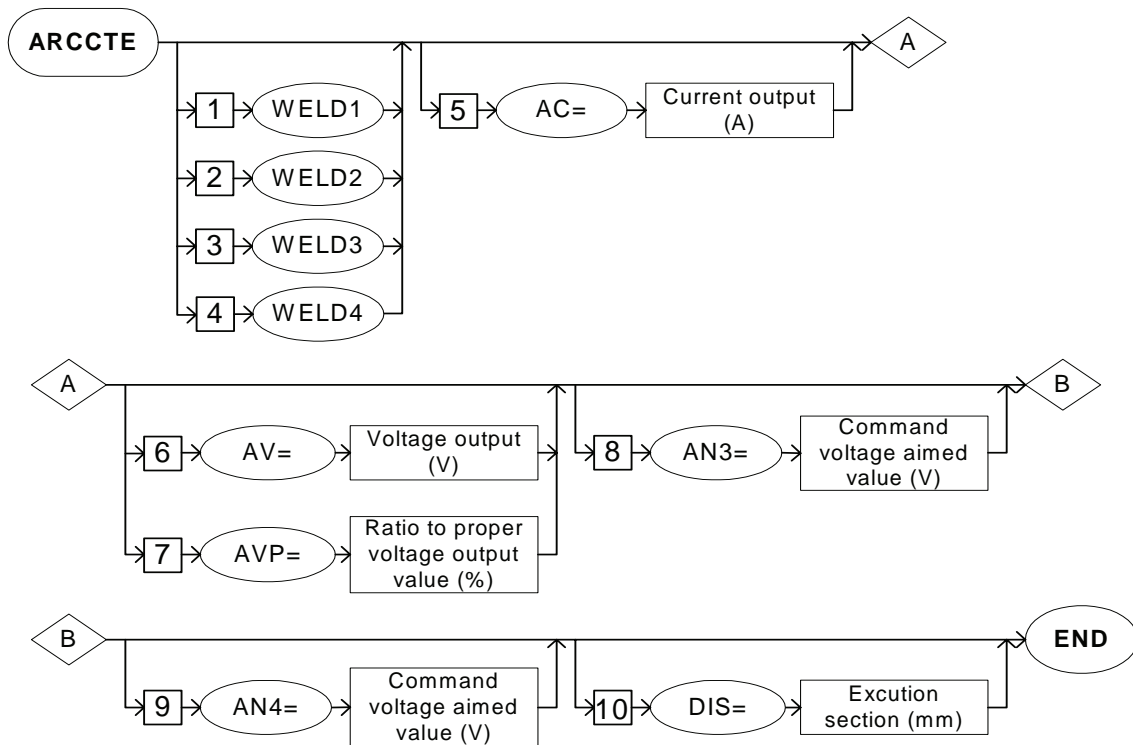

Explanation

1. WELD1 /WELD2/WELD3/WELD4

Choose one of the tags from the following table. These tags are valid for a system with multiple applications in which two or more arc welding applications are included. These tags are not displayed when there is only one application.

No	Tag	Explanation	Note
1	WELD1	Specifies Welder 1.	
2	WELD2	Specifies Welder 2.	
3	WELD3	Specifies Welder 3.	
4	WELD4	Specifies Welder 4.	

2. AC=Current output value

The following tag can be added or omitted.

No	Tag	Explanation	Note
5	AC=Current output value	Specifies the aimed value of the welding current.	Current value: 1 to 999A Variable B/I/D/B[]/I[]/D[]/LB/LI/LD/LB[]/LI[]/LD[] can be used.

3. AV=Voltage output value /AVP=Ratio to proper voltage output value

Choose one of the tags from the following table.

No	Tag	Explanation	Note
6	AV=Voltage output value	Specifies the aimed value of the welding voltage.	Voltage value: 0.1 V to 50.0 V Variable B/I/D/B[]/I[]/D[]/LB/LI/LD/LB[]/LI[]/LD[] can be used. (Units: 0.1 V)
7	AVP=Ratio to proper voltage output value	Specifies the aimed value for the welding voltage in the ratio to the proper voltage output value.	Ratio: 50% to 150% Variable B/I/D/B[]/I[]/D[]/LB/LI/LD/LB[]/LI[]/LD[] can be used.

2.7 Arc Welding Instruction

4. AN3=Aimed value of instruction voltage

The following tag can be added or omitted.

No	Tag	Explanation	Note
8	AN3=Aimed value of instruction voltage	Specifies the aimed value of the instruction voltage to analog output 3.	Aimed value: -14.00 V to +14.00 V Variable I/I[]/LI/LI[] can be used. (Units: 0.01 V)

5. AN4=Aimed value of instruction voltage

The following tag can be added or omitted.

No	Tag	Explanation	Note
9	AN4=Aimed value of instruction voltage	Specifies the aimed value of the instruction voltage to analog output 4.	Aimed value: -14.00 V to +14.00 V Variable I/I[]/LI/LI[] can be used. (Units: 0.01 V)

6. DIS=Execution section

The following tag can be added or omitted.

No	Tag	Explanation	Note
10	DIS=Execution section	Specifies the execution section where the current and the voltage are modified. The execution section is set by the distance from the moving start point. If the section is not specified, the entire section of the move instruction is regarded as the execution section.	Section: 0.1 mm to 6553.5 mm Variable B/I/D/B[]/I[]/D[]/LB/LI/LD/LB[]/LI[]/LD[] can be used. (Units: 0.1 mm)



For details of the slope up/down function, refer to the "Operator's Manual for the Arc Welding".

Example

(1) ARCCTE AC=150 AV=16.0 DIS=100.0

MOVL V=80

To make the welding current =150A and arc voltage =16V, the current and the voltage are changed in the section of 100mm from the move end point.

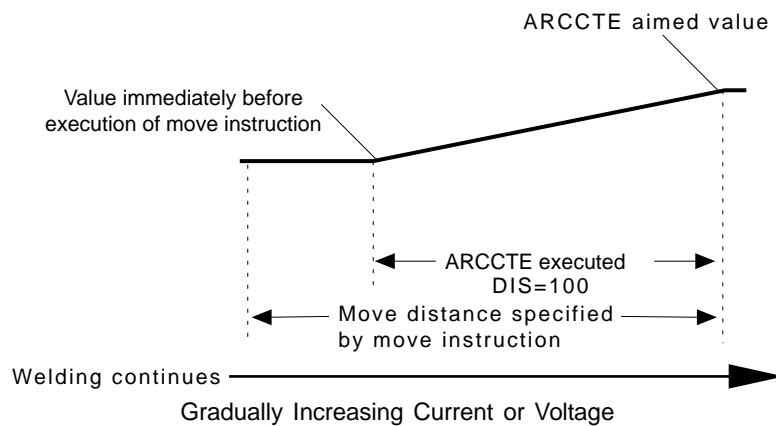
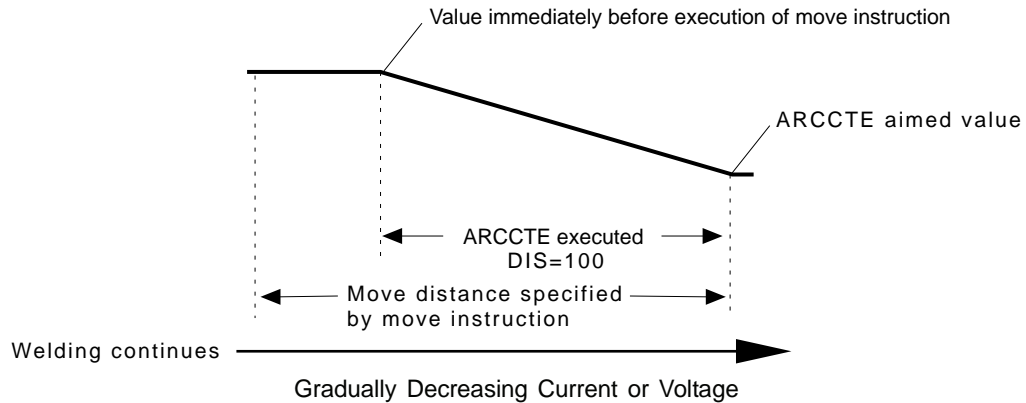

(2) ARCCTE AC=150 AV=16.0 AN3=7.50 AN4=6.50 DIS=100.0

To make the welding current =150A, arc voltage =16V, aimed value =7.5V of the instruction voltage to analog output 3, and aimed value =6.5V of the instruction voltage to analog output 4, the current and the voltage are changed in the section of 100mm from the move end point.

2.8 Handling Instruction

HAND

For handling applications
Instruction set:

SUBSET	STANDARD	EXPANDED
Available	Available	Available

Function

Turns the signal to the tool valve ON or OFF to control the tool.

Construction

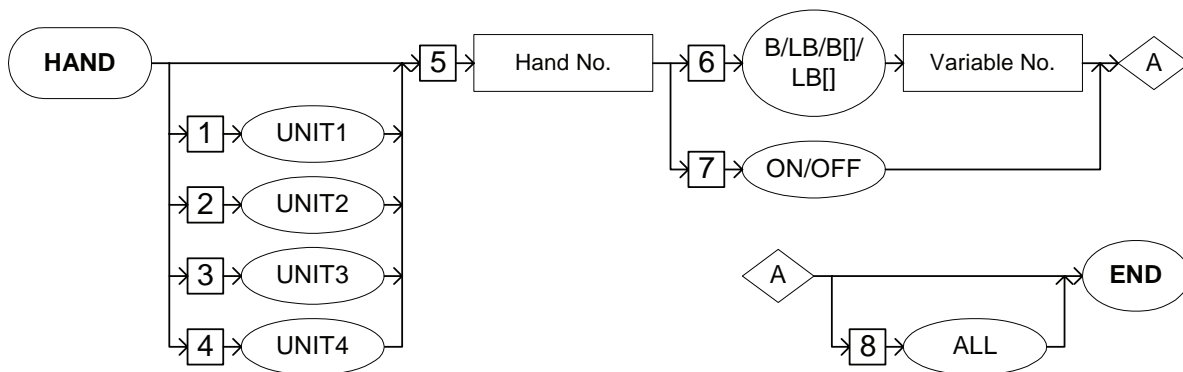

Explanation

1. UNIT1/UNIT2/UNIT3/UNIT4

Choose one of the tags from the following table. These tags are valid for a system with multiple applications in which two or more handling applications are included. These tags are not displayed when there is only one application.

No.	Tag	Explanation	Note
1	UNIT1	Specifies Device No. 1.	
2	UNIT2	Specifies Device No. 2.	
3	UNIT3	Specifies Device No. 3.	
4	UNIT4	Specifies Device No. 4.	

2. Hand number

Add the following tag.

No.	Tag	Explanation	Note
5	Hand number	Specifies the hand number.	No.: 1 to 4 Variable B/I/D/LB/LI/ LD can be used.

3. B Variable number/LB Variable number/B [Array number]/LB [Array number]/ON/OFF

Choose one of the tags from the following table.

No.	Tag	Explanation	Note
6	B Variable number/LB Variable number/ B [Array number]/ LB [Array number]	Refers the least significant bit of the specified byte type variable to specify the ON/OFF status of the signal to be sent to the tool valve.	Least significant bit: 0: OFF 1: ON
7	ON/OFF	Specifies the ON/OFF status of the signal to be sent to the tool valve.	

4. ALL

The following tag can be added or omitted.

No.	Tag	Explanation	Note
8	ALL	Specifies the simultaneous control of Valve 1 and Valve 2.	Used when a 3P solenoid is used.

Example

HAND 1 OFF

Turns OFF the signal output to tool valve 1.

HSEN

For handling applications
Instruction set:

SUBSET	STANDARD	EXPANDED
Available	Available	Available

Function

Monitors the input status of the tool sensor. Stores the result in the system variable \$B006.



For details of system variables, refer to GETS of " 2.3 Operating Instruction ".

Construction

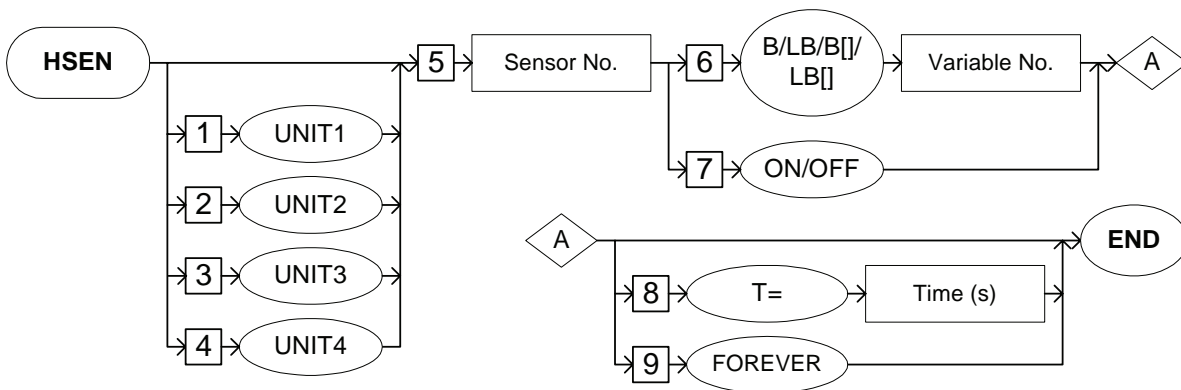

Explanation

1. UNIT1/UNIT2/UNIT3/UNIT4

Choose one of the tags from the following table. These tags are valid for a system with multiple applications in which two or more handling applications are included. These tags are not displayed when there is only one application.

No.	Tag	Explanation	Note
1	UNIT1	Specifies Device No. 1.	
2	UNIT2	Specifies Device No. 2.	
3	UNIT3	Specifies Device No. 3.	
4	UNIT4	Specifies Device No. 4.	

2. Sensor number

Add the following tag.

No.	Tag	Explanation	Note
5	Sensor number	Specifies the sensor number.	No.: 1 to 8 Variable B/I/D/LB/LI/ LD can be used.

3. B Variable number/LB Variable number/B [Array number]/LB [Array number]/ON/OFF

Choose one of the tags from the following table.

No.	Tag	Explanation	Note
6	B Variable number/LB Variable number/ B [Array number]/ LB [Array number]	Refers the least significant bit of the specified byte type variable to specify the ON/OFF status of the monitoring input status of the tool sensor.	Least significant bit: 0: OFF 1: ON
7	ON/OFF	Specifies the ON/OFF status of the monitor input of the tool sensor.	

4. T=Time/FOREVER

Choose one of the tags from the following table.

No.	Tag	Explanation	Note
8	T=Time	Specifies the time for monitoring the input status.	Units: seconds Variable I/LI/I[]/LI[] can be used. (Units: 0.01 seconds)
9	FOREVER	Specifies monitoring without a time limit.	

Example

HSEN 1 ON

Checks if sensor 1 is ON at the execution of an HSEN instruction and stores the result in the system variable \$B006.

1 is stored in \$B006 when sensor 1 is ON, 0 is stored when sensor 1 is OFF.

2.9 Spot Welding Instruction

GUNCL

For spot welding applications

Instruction set:

SUBSET	STANDARD	EXPANDED
Available	Available	Available

Function

Applies pressure to the air gun.

Construction

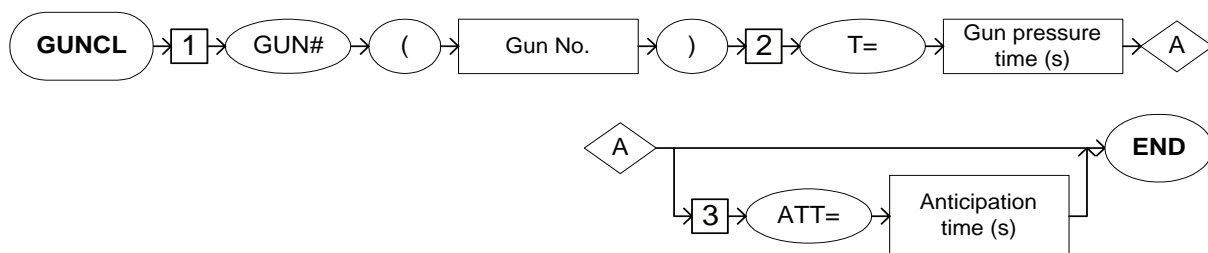

Explanation

1. GUN# (Gun number)

Add the following tag.

No.	Tag	Explanation	Note
1	GUN# (Gun number)	Specifies the number of the air gun to which pressure is applied.	No.: 1 to 8 Variable B/I/D/LB/LI/LD can be used.

2. T=Time

Add the following tag.

No.	Tag	Explanation	Note
2	T=Gun pressure time	Specifies the time during which the air gun is closed.	Units: seconds Variable I/LI/I[]/LI[] can be used. (Units: 0.01 seconds)

3. ATT= Anticipation time

The following tag can be added or omitted.

No.	Tag	Explanation	Note
3	ATT=Anticipaton time	Specifies the anticipation time for which the execution of the GUNCL instruction is advanced. The GUNCL instruction is carried out in advance for the specified time before reaching the step immediately before the GUNCL instruction. An NWAIT tag must be added to the move instruction of the step immediately before the GUNCL instruction.	Units: seconds Variable I/LI/I[]/LI[] can be used. (Units: 0.01 seconds)

Example

```
MOVL V=1000 NWAIT          • • • Step 5
GUNCL GUN#(1) T=2.00 ATT=0.50
```

Turns ON the Gun 1 pressure signal 0.5 seconds before the manipulator reaches Step 5, and turns it OFF 2 seconds later (1.5 seconds after the manipulator reaches Step 5).

SPOT

For spot welding applications

Instruction set:

SUBSET	STANDARD	EXPANDED
Available	Available	Available

Function

Starts the welding sequence after pressure has been applied to the air gun.

Construction

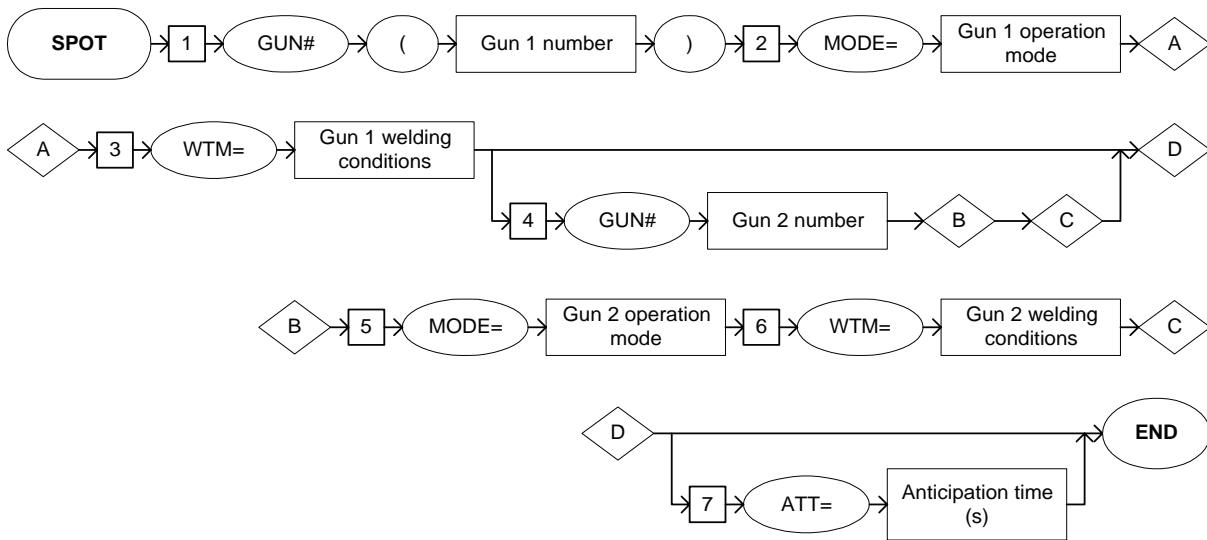

Explanation

1. GUN# (Gun 1 number)

Add the following tag.

No.	Tag	Explanation	Note
1	GUN# (Gun 1 number)	Specifies the number of the air gun to be used for welding. For a 2-gun system, specify the number of the first air gun.	No.: 1 to 8 Variable B/I/D/LB/LI/LD can be used.

2. MODE=Gun 1 operation mode

Add the following tag.

No.	Tag	Explanation	Note
2	MODE=Gun 1 operation mode	Specifies the operation mode of the air gun. For a 2-gun system, specify the operation mode of the first air gun.	Mode: 0 to 4 Variable B/B[]/LB/LB[]/I/I[]/LI/LI[]/D/D[]/LD/LD[] can be used.

**Gun operation mode**

The following table lists the settings and their operation modes.
For a 2-step stroke gun, make the settings according to the open status before and after welding.

Setting	Before Welding → After Welding
0	Single gun
1	Short open → Short open
2	Short open → Full open
3	Full open → Short open
4	Full open → Full open

3. WTM=Gun 1 welding condition

Add the following tag.

No.	Tag	Explanation	Note
3	WTM=Gun 1 welding condition	Specifies the welding condition number set for the welder. For a 2-gun welding system, set the welding condition number of the first air gun.	Condition No.: 1 to 255 Variable B/B[]/LB/LB[]/I/I[]/LI/LI[]/D/D[]/LD/LD[] can be used.

2.9 Spot Welding Instruction

4. GUN# (Gun 2 number)

The following tag can be added or omitted.

No.	Tag	Explanation	Note
4	Gun 2 number	Specifies the number of the air gun used for welding. For a 2-gun welding system, specify the number of the second air gun.	No.: 1 to 8 Variable B/I/D/LB/LI/ LD can be used.

5. MODE=Gun 2 operation mode

When a Gun 2 number (GUN#) is selected from the table in part 4 of this Explanation, add the following tag.

No.	Tag	Explanation	Note
5	MODE=Gun2 operation mode	Specifies the operation mode of the air gun. For a 2-gun welding system, specify the operation mode of the second air gun.	Mode: 0 to 4 Variable B/B[]/LB/ LB[]/I/I[]/LI/LI[]/D/D[]/ LD/LD[] can be used.

6. WTM=Gun 2 welding condition

When a Gun 2 number (GUN#) is selected from the table in part 4 of this Explanation, add the following tag after MODE=Gun 2 operation mode is selected from the table in part 5 of this Explanation.

No.	Tag	Explanation	Note
6	WTM=Gun 2 welding condition	Specifies the welding condition number set for the welder. For a 2-gun welding system, specify the welding condition number for the second air gun.	Condition No.: 1 to 255 Variable B/B[]/LB/ LB[]/I/I[]/LI/LI[]/D/D[]/ LD/LD[] can be used.

7. ATT=Anticipation time

The following tag can be added or omitted.

No.	Tag	Explanation	Note
7	ATT=Anticipation time	Specifies the anticipation time for which the execution of the SPOT instruction is advanced. The SPOT instruction is carried out in advance for the specified time before reaching the step immediately before the SPOT instruction. An NWAIT tag must be added to the move instruction of the step immediately before the SPOT instruction.	Units: seconds Variable I/LI/I[]/LI[] can be used. (Units: 0.01 seconds)

Example

```
MOVL V=1000 NWAIT           • • • Step 5
SPOT GUN#(1) MODE=2 WTM=5 ATT=0.50
```

0.5 seconds before the manipulator reaches Step 5, the spot welding sequence starts from the moment the air gun is short open, and the air gun is full open after the sequence is completed. Then the manipulator carries out the next step.

STROKE

For spot welding applications

Instruction set:

SUBSET	STANDARD	EXPANDED
Available	Available	Available

Function

Switches the open status of the 2-step stroke gun to/from Full open to/from Short open when not welding.

Construction

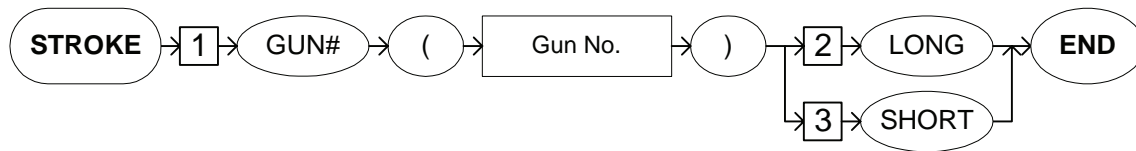

Explanation

1. GUN# (Gun number)

Add the following tag.

No.	Tag	Explanation	Note
1	Gun# (Gun number)	Specifies the number of the air gun whose open status is to be changed.	No.: 1 to 8 Variable B/I/D/LB/LI/LD can be used.

2. LONG/SHORT

Choose one of the tag from the following table.

No.	Tag	Explanation	Note
2	LONG	Specifies Full open.	
3	SHORT	Specifies Short open.	

Example

MOVL V=1000 NWAIT ... Step 5
STROKE GUN#(1) LONG

When the manipulator reaches Step 5, the stroke is changed to Full open to avoid interference, and then the manipulator moves to the next step.

STRWAIT

For spot welding applications

Instruction set:

SUBSET	STANDARD	EXPANDED
Available	Available	Available

Function

Confirms the specified open status of a 2-step stroke gun as short open or full open when not welding.

Wait until the signal of the specified open status, short open or full open, is turned ON.

Construction

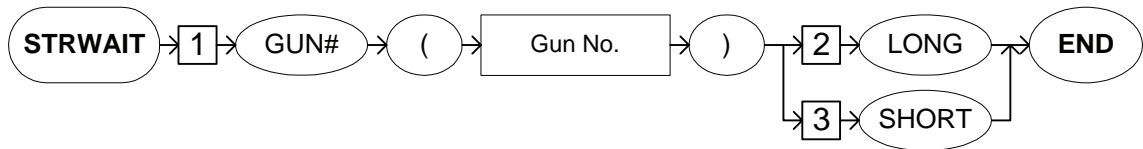

Explanation

1. GUN# (Gun number)

Add the following tag.

No.	Tag	Explanation	Note
1	GUN# (Gun number)	Specify the number of the air gun whose open status is to be confirmed.	No.: 1 to 8 Variable B/I/D/LB/LI/LD can be used.

2. LONG/SHORT

Choose one of the tags from the following table.

No.	Tag	Explanation	Note
2	LONG	Specify Full open.	
3	SHORT	Specify Short open.	

Example

```
MOVL V=1000 NWAIT    ... Step 5  
STROKE GUN#(1) LONG  
STRWAIT GUN#(1) LONG
```

When the manipulator reaches Step 5, the open status changes to Full open, and the manipulator confirms the Full open status before moving to the next step.

2.10 General-purpose Instruction

TOOLON

For general-purpose applications

Instruction set:

SUBSET	STANDARD	EXPANDED
Available	Available	Available

Function

Turns ON the work instruction.

Construction

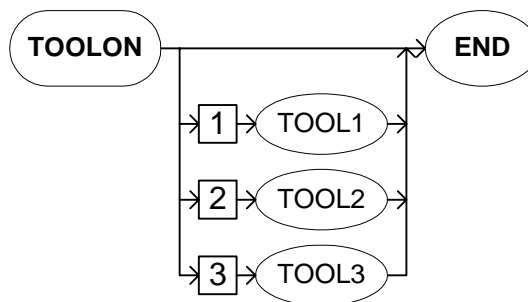

Explanation

1. TOOL1/TOOL2/TOOL3

Choose one of the tags from the following table. These tags are valid for a system with multiple applications in which two or more general-purpose applications are included. These tags are not displayed when there is only one application.

No.	Tag	Explanation	Note
1	TOOL1	Specifies Tool 1.	
2	TOOL2	Specifies Tool 2.	
3	TOOL3	Specifies Tool 3.	

Example

TOOLON

Turns ON the work instruction.

Turns ON the work start instruction (dedicated output relay #50770) and waits for the work start response (dedicated input relay #40570). When the work start response is turned ON, the next instruction is carried out.

The work start response relay is designed to turn ON immediately after the output of the work start instruction.

TOOLOF

For general-purpose applications

Instruction set:

SUBSET	STANDARD	EXPANDED
Available	Available	Available

Function

Turns OFF the work instruction.

Construction

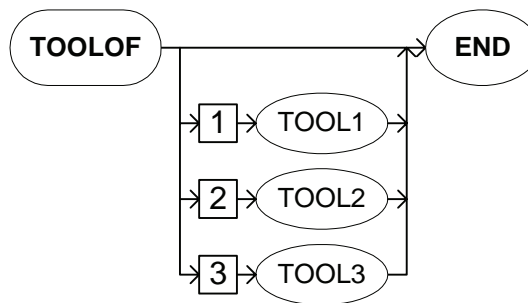

Explanation

1. TOOL1/TOOL2/TOOL3

Choose one of the tags from the following table. These tags are valid for a system with multiple applications in which two or more general-purpose applications are included. These tags are not displayed when there is only one application.

No.	Tag	Explanation	Note
1	TOOL1	Specifies Tool 1.	
2	TOOL2	Specifies Tool 2.	
3	TOOL3	Specifies Tool 2.	

Example

TOOLOF

Turns OFF the work instruction.

Turns ON the work end instruction (dedicated output relay #50771) and waits for the work end response (dedicated input relay #40571). When the work end response is turned ON, the next instruction is carried out.

The work end response relay is designed to turn ON immediately after the output of the work end instruction.

NX100

INFORM MANUAL

HEAD OFFICE

2-1 Kurosaki-Shiroishi, Yahatanishi-ku, Kitakyusyu-shi, 806-0004, Japan
Phone +81-93-645-7745 Fax +81-93-645-7746

MOTOMAN INC. HEADQUARTERS

805 Liberty Lane, West Carrollton, OH 45449, U.S.A.
Phone +1-937-847-6200 Fax +1-937-847-6277

MOTOMAN ROBOTICS EUROPE AB

Franska Vagen 10, Box 4004, SE-390 04 Kalmar, Sweden
Phone +46-480-417800 Fax +46-480-417999

MOTOMAN ROBOTEC GmbH

Kammerfeld strasse 1, 85391 Allershausen, Germany
Phone +49-8166-90-100 Fax +49-8166-90-103

YASKAWA ELECTRIC KOREA CORPORATION

1F, Samyang Bldg. 89-1, Shinchun-dong, Donk-Ku, Daegu, Korea
Phone +82-53-382-7844 Fax +82-53-382-7845

YASKAWA ELECTRIC (SINGAPORE) PTE. LTD.

151 Lorong Chuan, #04-01, New Tech Park, Singapore 556741
Phone +65-6282-3003 Fax +65-6289-3003

YASKAWA ELECTRIC (MALAYSIA) SDN. BHD.

Unit 47-1 and 2. Jalan PJU 5/9, Dataran Sunway, Kota Damansara, 47810, Petaling Jaya Selangor, Malaysia
Phone +60-3614-08919 Fax +60-3614-08929

YASKAWA ELECTRIC (THAILAND) CO., LTD.

252/246, 4th Floor. Muang Thai-Phatra office Tower II Rechedapisek Road, Huaykwang Bangkok 10320, Thailand
Phone +66-2-693-2200 Fax +66-2-693-4200

SHOUGANG MOTOMAN ROBOT CO., LTD.

No.7, Yongchang-North Road, Beijing Economic and Technological and Development Area, Beijing 100076, China
Phone +86-10-6788-0541 Fax +86-10-6788-0542

MOTOMAN MOTHERSON ROBOTICS LTD.

910, DLF Galleria, DLF City Phase IV, Gurgaon - 122002 Haryana, India
Phone +91-124-414-8514 Fax +91-124-414-8016



YASKAWA ELECTRIC CORPORATION

YASKAWA